

# Pioneering Future Innovation

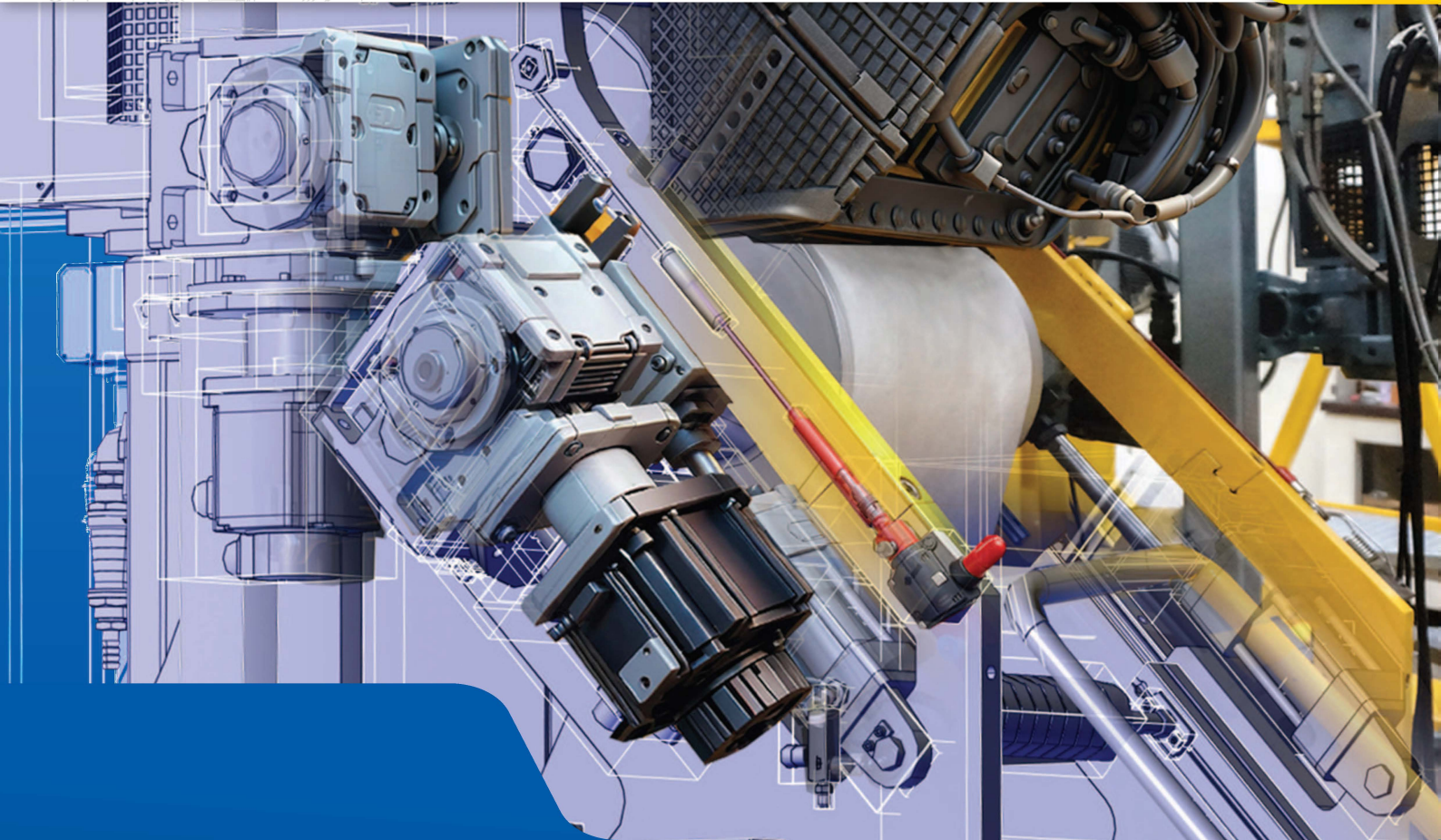

## **GENERAL CATALOGUE**

for Polymer Processing Machines

ULTRAMICRO, MINI, LAB, PILOT

Creating Solutions  
since **1983**

# COMPANY PROFILE

## Our Company

Established in 1983, our Thai-Swedish company has grown into the world's leading manufacturer of laboratory and pilot plant polymer processing machines.

## Our Capacity

With a dedicated workforce of 220, we produce over 500 machines annually. Notably, 90% of machines are exported, solidifying our global presence.

## Our Product

With our extensive product range, possibly the world's largest, we continue to innovate new machines every year and customize solutions to meet specific customer needs.



# Labtech Engineering

Company Limited

ISO 9001:2015

## Our Service

Prioritizing quality and customer satisfaction, we have a substantial stock of spare parts for prompt delivery. Our team of experienced technicians is ready to provide comprehensive after-sales support and technical assistance from global commissioning to on-site training.

## Our Solutions

Every customer's process is unique. That's why we provide fully customizable machines designed to match your specific applications and requirements. Simply share your information and needs with us, and our engineering team will work closely with you to deliver the perfect solution. We are also pleased to provide you with full details of every machine featured in our catalogue upon request.

# TABLE OF CONTENTS

<b>Compounding Lines</b> .....	01	<b>Press Machines</b> .....	62
Extruder Units.....	01	Benchtop Laboratory Scientific.....	63
Twin-Screw.....	01	Laboratory Scientific.....	63
Single-Screw.....	05	<b>Filter Testers</b> .....	65
Downstream Units.....	08	Filter Testers.....	65
High-Speed Mixers.....	14	Filter Packs.....	66
Sample Setups.....	16	<b>Benchtop Laboratory Scientific Lines</b> .....	67
<b>Blown Film Lines</b> .....	17	Compounding Line.....	67
Single-Layer.....	17	3D Filament Lines.....	68
Multi-Layer.....	21	Two-Roll Mill.....	68
Available Setups.....	29	Hydraulic Press.....	68
Sample Setups.....	31	Filter Tester.....	68
<b>Cast Film and Sheet Lines</b> .....	33	<b>Mini Scientific Lines</b> .....	69
Single-Layer.....	33	Blown Film Lines.....	69
Multi-Layer.....	37	Cast Film and Sheet Lines.....	69
Available Setups.....	41	Combi Blown and Cast Film Line.....	70
Sample Setups.....	44	Combi Compounding and 3D Filament Line.....	71
<b>MDO Stretching Machines</b> .....	45	Melt Spinning Line.....	72
Single Stretch Gap.....	45	<b>Ultramicro Scientific Lines</b> .....	73
Two Stretch Gaps.....	46	Blown Film Lines.....	73
<b>3D Filament, Pipe, Tube, Hose and Profile Lines</b> .....	47	Cast Film and Sheet Lines.....	73
3D Filament Lines.....	47	Combi Blown and Cast Film/Sheet Line.....	74
Pipe, Tube, Hose and Profile Lines.....	51	Compounding Line.....	74
<b>Bottle Blow Moulding Machines</b> .....	57	<b>Mark II Extrusion Lines</b> .....	75
Single-Layer.....	57	Twin-Screw Compounding Lines Mark II.....	75
Multi-Layer.....	58	Single-Screw Extruders Mark II.....	75
<b>Two-Roll Mills</b> .....	59	Blown Film Lines Mark II.....	76
Benchtop Laboratory Scientific.....	60	Cast Film Line Mark II.....	76
Laboratory Scientific.....	61		

# Extruder Units

## Twin-Screw Extruders

With over 21 years of experience in producing high-performance extrusion machines, Labtech Engineering Company stands at the forefront of innovation and quality in the industry.

Our commitment to continuous technological advancement and design improvement ensures that every machine we deliver offers superior performance and exceptional product quality.

### Standard Series

As the workhorse of the plastics industry, our Standard Twin-Screw Extruders are designed to meet diverse requirements with a wide range of sizes, from lab to pilot scale demands.

The extruders are designed for ergonomic operation, enhancing user comfort and efficiency. Engineered to handle nearly all types of plastic materials and additives, our machines guarantee reliable and high performance.

### Lab Scientific



Type LTE12



Type LTE16



Type LTE20



### Technical Specifications

Standard Twin-Screw Extruders		LTE12	LTE16	LTE20		LTE26	
				Standard	Maxi	Standard	Maxi
Available L/D Ratio	-	35 and 40	32 to 56	32 to 56		32 to 60	
Maximum Screw Speed	RPM	up to 800		up to 800	up to 1200	up to 800	up to 1200
Maximum Extrusion Output Pressure	bar	200					
Maximum Standard Barrel Temperature	°C	400					
Estimated Maximum Output (LDPE)	kg/hr	4	5.4	21	31	64	80
Dimensions (L x W x H)	m	1.80 x 0.71 x 1.76 (35 L/D)	1.84 x 0.79 x 1.77 (40 L/D)	2.16 x 0.71 x 1.81 (40 L/D)		2.84 x 0.88 x 1.96 (40 L/D)	

**NOTE** Extruder output varies based on material and downstream equipment.

## Features

- User-friendly comprehensive controls
- Simple operation & easy maintenance
- High-efficiency heating & cooling system
- Extremely precise temperature control
- Versatile screw configuration
- Clamshell barrel design for easy cleaning
- Excellent material distribution & dispersion
- Customizable feeding hopper system
- Designed for co-rotating and/or counter-rotating operation

## Options

- Water Trap & Water Ring Vacuum System
- Induction or Water-Cooled Motor
- Volumetric & Gravimetric Feeders
- Barrel Venting with built-in Vacuum System
- Abrasion & Corrosion Resistance Extruder
- Volumetric & Gravimetric Liquid Dosing Feeder
- High-Heat Version (450°C) for Engineering Plastics
- Computerized Touchscreen Control & SCADA Software
- Customized Screw Element Configuration
- Screen Changer for Contaminant Removal

## Materials

- Thermoplastic Elastomers
- Biodegradable Polymers (PLA, Starch-Based Materials)
- Recycled Materials
- Masterbatches and Additive Compounds
- Commodity Plastics (Polyolefin, PVC, Styrene Polymers)
- Engineering Plastics (Polyamides, PC) PEEK, PSU
- Masterbatches and Additive Compounds



## Pilot

LTECC26		LTE36	
Co Rotating	Counter Rotating	Standard	Maxi
40 to 44		40 to 60	
up to 800	up to 400	up to 900	up to 1200
250			
64	50 (PVC material)	200	330
2.60 x 0.81 x 1.95 (40 L/D)		3.93 x 1.02 x 1.80 (40 L/D)	

## Applications

- Compound and Composite Polymer Production
- Film, Sheet, Pipe, and Tube Extrusion Processes
- Research and Development of New Materials
- Reactive Extrusion Process
- Recycling Plastic Process
- Masterbatch Production

## Pharmaceutical Series

Specifically designed to meet the demands of pharmaceutical applications, our hygienic design ensures easy adaptability within clean production environments.

### Features

- Durable GMP stainless steel build
- Easy access clamshell barrel design
- Flexible segmented screw configuration
- Comprehensive operator safety systems
- Designed for easy dismantling and cleaning

Available in a wide range of sizes, our extruders can also be customized to meet specific customer requirements to provide both flexibility and efficiency in the operation.

### Options

- Gravimetric Hoppers and Liquid Dosing Feeders
- Screen Changer
- Customized Screw Element Configuration
- Barrel Venting with built-in Vacuum System
- Water Ring Vacuum System

## Lab Scientific



Type LTEP12



Type LTEP26

### Materials

- Thermoplastics or Biopolymers compatible with Pharmaceutical Applications
- Active Pharmaceutical Ingredients
- Additives and Preservatives

### Applications

- Microcapsules and Nanocapsules
- Pharmaceutical Polymer Blends and Composites
- Controlled Release Drug Delivery Systems
- Active Pharmaceutical Ingredient Processing
- Medical Materials Parameter Optimization

### Technical Specifications

Twin-Screw Extruders		Pharmaceutical			
		LTEP16	LTEP20	LTEP26	LTEF16
Available L/D Ratio	-	32 to 40			
Maximum Screw Speed	RPM	up to 800			
Maximum Extrusion Output Pressure	bar	200	250		200
Maximum Standard Barrel Temperature	°C	300			
Estimated Maximum Output (LDPE)	kg/hr	5	18	40	5
Dimensions (L x W x H)	m	1.84 x 0.79 x 1.77 (40 L/D)	2.16 x 0.71 x 1.81 (40 L/D)	2.84 x 0.88 x 1.96 (40 L/D)	1.84 x 0.79 x 1.77 (40 L/D)

**NOTE** Extruder output varies based on material and downstream equipment.

## Food Series

Seamlessly integrated with downstream equipment to process low-moisture snacks for texture and puffing control, and high moisture pastas for preserved hydration.

### Features

- GMP compliant with advanced technology
- Consistent and repeatable production results
- Excellent homogeneous mixing
- Easy and safe to operate

## Powder Coating

Specialized design, coupled to chill roll unit and vibration feeding system, forming flat and brittle flakes from compounded thermosetting resin powder.

### Features

- Consistent batch quality
- Accurate fine particle feeding without bridging
- Short cleaning time duration
- Solvent-free process

## Lab Scientific



Type LTEF26

## Lab Scientific



Type LTE16-24PC

### Materials

- Cereals, Legumes & Proteins
- Vitamins, Flavorings & Seasonings
- Salts, Sugars, Oils & Fats

### Materials

- Binder Resins: Polyester, Polyurethane, Acrylics
- Curing Agents
- Pigments: Titanium Dioxide, Carbon Black
- Fillers: Calcium Carbonate, Talc

Food		Powder Coating
LTEF20	LTEF26	LTE16/PC
32 to 40		24
up to 800		up to 800
	250	200
		400
18	40	4
2.16 x 0.71 x 1.81 (40 L/D)	2.84 x 0.88 x 1.96 (40 L/D)	1.89 x 0.59 x 1.74 (24 L/D)

### Applications

- Extruded Puffs, Chips, Cereals, Snacks & Pet Food
- High-Moisture Meat Analogue Processing
- Protective and Decorative Powder Coatings for Polymer Products: Automotive, Furniture, Appliances, Sporting Goods

# Single-Screw Extruders

With decades of experience and commitment to innovation, Labtech Engineering has built a strong reputation in extrusion technology. Our Single-Screw Extruders have expanded from reliable standard types to specialized recycling solutions, offering top performance, durability, and versatility.

## Standard Series

Labtech's standard Single-Screw Extruders are available in a wide range of sizes, from ultramicro to pilot scale. These versatile extruders are compatible with various downstream units, including Blown Film, Cast Film, 3D Filament, and Blow Moulding.

Our Single-Screw Extruders can process a broad spectrum of polymers, from commodity plastics to advanced engineering thermoplastics, ensuring maximum flexibility and performance. Numerous additional options are also available to meet diverse customer requirements.

### Ultramicro Scientific

### Mini Scientific

### Lab Scientific



Type LUME8-30/C



Type LME16-30/C



Type LE20-30/C



Type LE25-30/C



Type LE12.5-30/C

Standard Single-Screw Extruders			Technical Specifications			
			LUME8-30/C	LE12.5-30/C	LE16-30/C	LE20-30/C
Screw Diameter	mm		8 Conical Screw	12.5 Conical Screw	16	20
Available L/D Ratio	-					
Maximum Screw Speed	RPM		up to 300	up to 150		
Number of Heating Zones on Barrel	-		2	3	2	3
Maximum Standard Barrel Temperature	°C					
Estimated Maximum Output (LDPE)	for Strand Pelletizing	kg/hr	0.8	1	2.3	6
	for Cast/Blown Film	kg/hr	0.6	0.8	2	4.5
Motor Power	kW		0.75	1.5	0.75	1.5
Dimensions (L x W x H)	m		0.47 x 0.17 x 0.52	1.55 x 0.69 x 1.82	1.25 x 0.45 x 1.40	1.73 x 0.61 x 1.83

**NOTE** Extruder output varies based on material and downstream equipment.

## Features

- Budget-friendly design
- User-friendly operation
- High-precision temperature control
- Versatile screw options (plain, venting, mixing and barrier) to suit different processing needs
- High-quality performance
- Configurable for multilayer extrusion processes
- Flexible integration with numerous downstream units
- Streamlined one-pillar design for efficient workspace

## Materials

- Recycled Materials
- Engineering Plastics (Polyamides, PC, ABS, POM, PEEK)
- Thermoplastic Elastomers
- Masterbatches and Blends

## Options

- Starve Feeders
- Bimetallic Barrel and Screw
- Hydraulic Screen Changers
- Computerized Controls
- Customized Screw Design
- Volumetric Hopper Feeder
- Vented Single-Screw Extruder
- Grooved Barrel at in-feed section
- Pressure and Melt Temperature Transducer
- High-Torque and Vector Motor Drive Options

- Biodegradable Polymers (PLA, Starch-Based Materials)
- Commodity Plastics (Polyolefin, PET, Styrene Polymers)

## Pilot



LE30-30/C



Type LE40-30/CV



Type LE45-30/C



Type LE60-30/C

LE25-30/C	LE30-30/C	LE40-30/C	LE45-30/C	LE60-30/C
25	30	40	45	60
30:1				
up to 300	up to 200			up to 140
4				
300				
15	20	43	60	100
11	14	30	40	80
4	7.5	15	27 (Vector Motor)	50 (Vector Motor)
2.23 x 0.78 x 1.83	2.47 x 0.78 x 1.84	2.46 x 0.76 x 1.88	2.58 x 0.76 x 1.88	3.50 x 1.13 x 1.84



Optional Touchscreen Interface

## Applications

- Process Optimization
- Polymer Characterization
- Compatible with Various Plastic Processing (Film, Sheet, Filament, Blow Moulding)

## Recycling Series

Labtech's Single-Screw Recycling Extruders Mark II are designed with advanced features to efficiently process large volumes of plastic waste. Equipped with a special screw design for recycling materials, these extruders are well-suited for handling sizable flakes and shredded plastic materials.

The 16 mm Mini Scientific Recycling Extruder is available in two L/D ratios: 25 L/D and 30 L/D, configured to meet various recycling operations and production targets. Specialized feeders optimize material intake for efficient feeding performance, especially with low-density plastics.



Type LREX16-25/MARK II



Type LREX16-30/MARK II

### Features

- Ease of operation
- Minimize shear stress
- Low power consumption
- Reduce material degradation
- Vacuum vent for volatile removal and pressure elimination
- Touchscreen interface

### Materials

- Polypropylene (PP)
- Polyethylene (PE)
- Polyethylene Terephthalate (PET)

### Applications

- Converting Post-Consumer and Post-Industrial Plastic Waste into Reusable Pellets
- Material Testing of Different Recycled Materials
- Developing Compounds and Composites from Recycled Materials
- Optimizing Extrusion Process Parameters for Recycled Products

### Technical Specifications

Recycling Single-Screw Extruders Mark II			LREX16-25/MARK II	LREX16-30/MARK II
Screw Diameter	mm		16 Conical Screw	16 Conical Screw
Available L/D Ratio	-		25:1	30:1
Maximum Screw Speed	RPM		up to 150	up to 150
Number of Heating Zones on Barrel	-		6	6
Maximum Standard Barrel Temperature	°C		300	300
Estimated Maximum Output (R-HDPE flake)	for Strand Pelletizing	kg/hr	3-4	3-4
	for Cast/Blown Film	kg/hr	2-3	2-3
Motor Power	kW		2.2	2.2
Dimensions (L x W x H)	m		1.27 x 0.61 x 1.67	1.29 x 0.66 x 1.70

**NOTE** Extruder output varies based on material and downstream equipment.

# Downstream Units

Labtech's Downstream Units are designed to enhance the performance of both Twin-Screw and Single-Screw Extruders for efficient polymer compounding and material handling. These systems include a variety of solutions for transforming molten polymer into solid pellets.

Our solidification techniques (water baths and air conveyors) and pelletization options (strand pelletizers, sidecut pelletizers, air-cooled die-face cutters and underwater pelletizers) are able to accommodate diverse material types and production requirements.

## Water Baths

Our cooling technology solutions, from high-capacity to compact benchtop designs, effectively solidify polymer strands and produce exceptional pellet quality.



Type LWB-40



Type LW-100/L



Type LW-300

### Features

- Powerful vacuum strand suction
- Built-in water circulation system
- Adjustable submersion strand rolls
- Automated pump with water level sensor

### Options

- Chiller Cooling System
- Strand Blower Assembly
- Water Circulating Pump
- Extended Water Tank Length
- Closed-Loop Heat Exchanger
- Strand Roller with Stainless Steel Arm and Quick-Lock System

### Materials

- Non-Water Sensitive Materials

### Technical Specifications

Water Baths		LWB-40	LW-100	LW-100/L	LW-300
Water Capacity	L	40	80	110	260
Water Tank Length	m	1.2	1.5	2	3
Water Pump Motor Power	kW	0.37	0.37	0.37	1.5
Dimensions (L x W x H)	m	2.05 x 0.69 x 1.70	1.55 x 0.63 x 1.20	2.05 x 0.63 x 1.20	3.60 x 0.81 x 1.47

## Air-Cooling Conveyors

Labtech's Air-Cooling Conveyors are available for thermoplastic and pharmaceutical processing. The combination of moving belt and powerful airflow rapidly reduces materials temperature for optimal product quality and consistency.

### Standard Series

The Air-Cooling Conveyor features stainless steel mesh belt and high-powered propeller fans for optimal airflow, cooling hot extruded materials from the twin-screw extruder before further processing. Without proper cooling, extruded strands remain too soft to handle and may stick together.

#### Features

- Durable construction built for long-lasting performance
- Adjustable side guides for various strand quantities
- Improved pelletization forming cohesive pellets

#### Materials

- Sticky & Fragile Resin Strands
- Ideal for Moisture-Sensitive Resins (Hydrophilic Polymers)



Type LAC-1.2



Type LAC-2.6

#### Options

- Customizable Belt Length and Number of Propeller Fans

### Pharmaceutical Series

Specialized conveyor system designed to rapidly cool pharmaceutical compounds as they move along an air-cooling belt to solidify strands and prevent sticking.

#### Features

- GMP approved non-sticking food-grade Teflon belt
- Precise belt speed regulation
- Plexiglas belt lid cover to prevent contamination

#### Options

- Customizable Belt Length and Number of Propeller Fans

#### Materials

- Pharmaceutical Polymers (PLA, PEG, PVA, PCL, etc.)



Type LACP-1.2



Type LACP-3.5

### Technical Specifications

Air-Cooling Conveyors		Standard		Pharmaceutical	
		LAC-1.2	LAC-2.6	LACP-1.2	LACP-2.6
Cooling Fans	units	4	8	4	8
Maximum Belt Speed	m/min	25			
Belt Motor Power	kW	0.18			
Dimensions (L x W x H)	m	1.30 x 0.59 x 1.18	2.72 x 0.59 x 1.18	1.30 x 0.51 x 1.29	3.66 x 0.53 x 1.50

# Strand Pelletizers

Labtech's Pelletizers offer exceptional precision, durability, and efficiency. Designed to handle water-sensitive or non-sensitive materials, these pelletizers provide reliable performance for a variety of applications.

## Standard Series

### Features

- Smooth and even strand pulling
- Safety interlocks for user protection
- Durable double-edged sharp knives
- Easy gap adjustment and speed control



Type LZ-80



Type LZ-120



Type LZ-200

### Options

- Classifier
- Rubber Strand Feeding Roll
- Stainless Steel Rotary Knives
- Tungsten Carbide Knife Edges
- Variable Speed Strand Feeding Device
- Precise pellet length control

### Materials

- Blend and Composite Strands
- Engineering Plastics (Nylon, PC)
- Commodity Plastics (PE, PP, PVC, PS)
- Biodegradable Polymers (PLA, Starch-Based Polymers)

## Pharmaceutical Series

### Features

- Ensures Consistent Pellet Dosage
- Sterile Construction for Product Purity
- Safe Operation with Interlock Systems
- Consistent Pellet Quality



Type LZP-80



Type LZP-120

## Technical Specifications

Strand Pelletizers		Standard			Pharmaceutical	
		LZ-80	LZ-120	LZ-200	LZP-80	LZP-120
Pellet Diameter Range	mm	Ø 1 to Ø 5			Ø 1 to Ø 5	
Pellet Length Range	for Standard	3			3	
	for Variable-Speed Option	1.0 to 5.0	1.0 to 6.0		1.0 to 5.0	1.0 to 6.0
Number of Rotary Knives	-	6	20	32	6	20
Maximum Number of Strands (3 mm)	-	2	8	24	2	8
Maximum In-Feed Speed	m/min	36	72	95	36	72
Estimated Maximum Output (ρ = 1 kg/m <sup>3</sup> )	kg/hr	30	120	360	30	120
Dimensions (L x W x H)	m	0.55 x 0.47 x 1.71	0.72 x 0.70 x 1.40	0.60 x 0.90 x 1.82	0.55 x 0.47 x 1.71	0.72 x 0.70 x 1.40

## Sidecut Pelletizer

Unique strand pelletizing concept for thermoplastics from the softest to the most rigid engineering resins featuring a fan-shaped cutting wheel that cuts the strands sideways with a scissors action.

### Options

- Classifier
- Platform

### Applications

- Produce Micropellets
- Produce Compounds and Masterbatches

### Features

- Durable construction
- Prevents dust and pellet shattering
- Consistent and uniform pellet shape
- Pelletize very hard and brittle materials
- Pelletize very soft (as low as 10 Shore A) and hot melt materials
- Produce extremely small pellets as 0.4 x 0.4 mm
- Operate at very high speed without sacrificing quality



Type LSC-108

Standard Pellets (3 x 3)

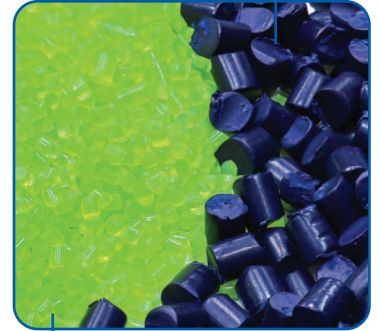

Micropellets (0.4 x 0.4)

### Materials

- Rubber-Based Polymers
- Thermoplastic Elastomers (TPEs) (e.g. Polyurethane)
- Fibrous Materials and their Composites
- Food Strands (e.g. Rice Noodle) with High Moisture Content

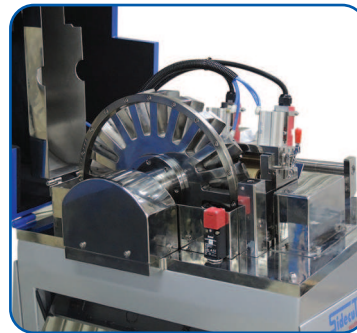

Unique Cutting Rotor

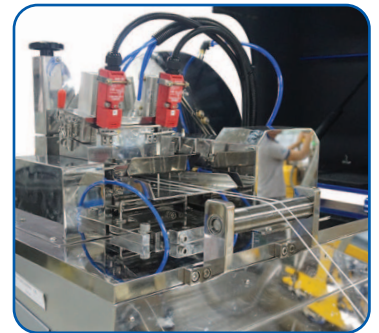

Strand Feeding Section

### Technical Specifications

Sidecut Pelletizer		Micro Pellet				
		LSC-112M	LSC-1520M	LSC-2520M	LSC-108	LSC-1512
Pellet Diameter Range	mm	Ø 0.40 to Ø 1.5				
Pellet Length Range	mm	0.40 to 10				
Number of Rotary Knives	-	12	20		8	12
Maximum Feed Speed	m/min	18	30		43	54
Pellet Size (Diameter x Length)	mm	Ø 1.0 x 1.0				
Maximum Number of Strands	-	18	36	75	6	12
Estimated Maximum Output	kg/hr	15	51	106	108	275
Dimensions (L x W x H)	m	0.81 x 1.06 x 1.64	0.99 x 1.30 x 1.71	1.03 x 1.30 x 1.74	0.81 x 1.06 x 1.64	0.99 x 1.30 x 1.71

## Air-Cooled Die-Face Cutter

Specialized cutter designed for cutting pellets directly on the die face, using high-speed air cooling for efficient separation of pelletized material. This unit is particularly suitable for processing water-sensitive materials.



Type LFC-15

### Features

- Zigzag pathway design extends cooling contact time
- Maximizes floor space efficiency
- Low maintenance design maximizes production uptime
- Multiple safety features
- Prevents material sticking
- Adjustable cutting blade force
- Easy-to-use operation controls
- Suitable for water-sensitive materials
- Rapid air-forced pellet cooling system

### Options

- Classifier

### Applications

- Produce Small Precision Sizes of Pellets

### Materials

- PVC
- Fiber Composites
- Water-Sensitive Materials
- Certain Biodegradable Materials (Starch-Based Materials)



Type LFC-26

Standard Pellet		
LSC-1516	LSC-2512	LSC-2516
Ø 1 to Ø 5		
1.0 to 10		
16	12	16
72	54	72
Ø 3.0 x 3.0		
12	25	25
366	573	763
0.99 x 1.30 x 1.71	1.03 x 1.30 x 1.74	1.03 x 1.30 x 1.74

Technical Specifications			
Air-Cooled Die-Face Cutters		LFC-15	LFC-26
Die Plate Hole	hole	1 to 2	8 to 20
Die Plate Hole Diameter	mm	3	3
Die Plate Maximum Temperature	°C	300	300
Number of Rotary Knives	-	2	2 or 4
Rotary Knife Speed Range	RPM	1000	1500
Conveying Pipe Length	m	1.2	6.8
Estimated Maximum Output (PVC)	kg/hr	5	35
Dimensions (L x W x H)	m	2.19 x 0.57 x 1.39	3.65 x 0.84 x 2.09

## Underwater Pelletizer

The underwater pelletizing system comprises an extruder, a cutting chamber with closed-loop water circulating system, and a centrifugal drying system.

Molten plastic is extruded directly into the cutting chamber, where it is submerged in water and simultaneously cut into uniform pellets by high-speed blades.

This rapid water-cooling process creates smooth, consistently shaped pellets while preventing them from sticking.



Type LUP-5 with LTE16-40

### Features

- Consistent pellet shape and size
- Efficient pellet separation system
- Easy to operate, clean, and maintain
- Compact size to fit in limited spaces
- Silent operation with minimal process noise
- Minimal water consumption through smart circulation

### Options

- 16 mm Twin-Screw Extruder
- 16 mm or 20 mm Single-Screw Extruder

### Materials

- Thermoplastic Materials (PP, PE, etc.)

### Applications

- Polymer Production
- Compounding and Masterbatch Production
- Optimizing Parameter Settings for Upscaling
- Developing Methods for Pellet Quality Control
- Laboratory Research in Polymer Characterization

### Technical Specifications

Underwater Pelletizer		LUP-5
Die Plate Hole	hole	2
Die Plate Diameter	mm	3.3
Maximum Pelletizing Speed	RPM	2000
Maximum Heater Temperature	°C	300
Maximum Centrifugal Impeller Speed	RPM	3000
Dimensions (L x W x H)	m	1.50 x 0.90 x 1.66

# High-Speed Mixers

Labtech's High-Speed Mixers deliver homogeneous polymer blends, providing precise dispersion of resins, additives, and colorants to ensure consistent composition and physical properties. Engineered for rapid, uniform mixing, they prevent clumping, optimize material quality, and prepare blends for extrusion to enhance process efficiency, reduce waste, and ensure consistent pellet quality, delivering reliable, high-performance results in compounding applications.

## Mini and Benchtop Laboratory Scientific

Labtech's Benchtop Mixers, with 1.5L, 5L and 10L capacities, are optimized for handling light mixing tasks. They excel at rapidly blending dry powders and additives for precise polymer compounding. Their compact design ensures uniform mixing, enhancing material consistency, pellet quality, and processing reliability.

### Mini Scientific



Type LMX1.5-VS

with optional Subcabinet

### Lab Scientific



Type LMX5-VS



Type LMX10-VS

### Features

- User-friendly control panel features
- Durable and hygienic stainless steel construction for bowl, impeller and lid
- Mixing process with two-bladed impellers
- Easy assembly, disassembly, and cleaning
- Safe operation with safety interlock switch

### Materials

- Dry Powders such as Pharmaceuticals, Minerals, Plastic Powders, Pigments, Fillers, and Additives (both Solid and Liquid Forms)

### Options

- Temperature Readout
- Spare Parts of Bowl, Lid with Deflector and Impeller

### Applications

- Deagglomerating Clumps of Particles
- Mixing and Homogenizing the Mixtures

### Technical Specifications

High-Speed Mixers		LMX1.5-VS	LMX5-VS	LMX10-VS
Mixer Bowl Volume	L	1.5	5	10
Maximum Mixing Volume	L	1	3.3	6.7
Maximum Impeller Speed	RPM	5000	3000	
Motor Power	kW	0.75	1.5	2.2
Dimensions (L x W x H)	m	0.58 x 0.37 x 0.60	0.69 x 0.45 x 0.68	0.69 x 0.45 x 0.77

## Laboratory Scientific

Labtech's Laboratory Scientific Mixers are built for intensive laboratory mixing applications, providing efficient blending of high-volume polymer compounds. Featuring jacketed vessels for accurate water temperature control, they ensure rapid, consistent mixing, optimizing material homogeneity for overall compounding performance.



Type LMX5-S-VS



Type LMX10-S-VS  
with LCM-24 (Option)



Type LMX25-VS/W



Type LMX75-VS/W

### Features

- Stainless-steel bowl with polished inner surface
- Safe operation with safety interlock switch
- Self-cleaning mixing tool for easy maintenance
- Filter with a valve on the lid for a dust-free air discharge
- Jacketed mixing vessel for precise water temperature control

### Options

- Available in Manual or Computerized Versions
- Cooling Mixer Chopper to break up Agglomerates
- Cooling Mixer Bowl for precise temperature control
- Water-Cooling Impellers and Shaft for heat-sensitive and sticky mixtures (available for 25 and 75 only)

## Cooling Mixer

### Features

- Standalone unit and can be easily integrated with the High-Speed Mixer
- Features a large-diameter vessel, cooled around its entire circumference and bottom
- Includes a self-digital timer for setting the cooling cycle
- Jacketed design with ambient water temperature

### Materials

- Dry Powders such as Pharmaceuticals, Minerals, Plastic Powders, Pigments, Fillers, and Additives (both Solid and Liquid Forms)
- Mixing Powders with Additive, Fillers, Colorants, Reinforcing Agents

### Applications

- Formulation Development
- Product Texture Optimization
- Polymer Compounding Pharmaceuticals, Food and Cosmetics Industry



Type LCM-24

## Technical Specifications

Laboratory Scientific Mixers		High-Speed Mixers				Cooling Mixers	
		LMX5-S-VS LMX5-S-VSFI	LMX10-S-VS LMX10-S-VSFI	LMX25-VS/W	LMX75-VS/W	LCM-12 (For LMX5-S)	LCM-24 (For LMX10-S)
Mixer Bowl Volume	L	7.8	11	25	75	12	24
Max Mixing Volume	L	5.2	7.3	16	50	6	12
Max Impeller Speed	RPM	4000		2500	1300	500	450
Motor Power	kW	4		11	22	0.37	0.75
Dimensions (L x W x H)	m	1.19 x 0.59 x 1.47	1.20 x 0.60 x 1.44	2.53 x 0.71 x 1.18	2.92 x 0.79 x 1.57	0.80 x 0.86 x 0.88	0.85 x 0.86 x 0.93

# Compounding Line Sample Setups

## Standard Compounding Line with Platform

36 mm Twin-Screw Extruder

Type LTE36-40

- Side Feeder
- Gravimetric Feeders (x3)
- Volumetric Liquid Doser and Platform

Water Bath

Type LW-300

Strand Pelletizer

Type LZ-200



## Pharmaceutical Compounding Line



12 mm Pharmaceutical  
Twin-Screw Extruder  
Type LTEP12-40  
with Gravimetric Feeder

Pharmaceutical Air-Conveyor  
Type LACP-1.2

Pharmaceutical Pelletizer  
Type LZP-80VS

# Blown Film Single-Layer Extrusion

Labtech Engineering offers a comprehensive range of Blown Film Extrusion Lines, from single-layer to multilayer films. Featuring precise temperature control and easy-to-manage process parameters, our blown film lines ensure optimal performance and quality for all your film production needs.

With extruders available in various sizes, from precise ultramicro-scale testing to industrial pilot-scale production, our machines are designed to fit both small spaces and high-capacity manufacturing environments.

## Ultramicro Scientific

The Ultramicro Blown Film Line is a highly specialized machine designed for small-scale sample production and precise research testing applications.

Optimized for material research and small-batch prototyping, it ensures minimal material consumption and accurate temperature control.

### Features

- Space-saving design with minimal resin usage
- Quick color changeovers
- Spiral mandrel die with adjustable lip centering
- Precise film thickness control
- Efficient high-velocity cooling
- User-friendly digital control panel

### Options

- Two-Station Wind-Up Unit

### Materials

- Polyethylene (PE)
- Biodegradable Polymers

### Applications

- Polymer Behavior and Film Structure Research
- Product Prototyping New Film-Based Products
- Process Optimization for Commercialization Scale-Up



Type LUMF-150

### Technical Specifications

Ultramicro Scientific Blown Film Extrusion Line		LUMF-150
Maximum Film Lay Flat Width	mm	100
Minimum Film Thickness <small>(depending on resin type)</small>	µm	20
Standard Film Die Diameter <small>(others on request)</small>	mm	Ø 20
Die Lip Gap	mm	0.8
Height from Die to Nip-Roll	mm	450 to 700
Maximum Line Speed	m/min	5
Dimensions (L x W x H)	m	1.38 x 0.75 x 1.57

# ion Lines

## Mini Scientific

Innovative system combining advanced engineering with user-centric design, offering a viable cost-effective alternative to regular blown film extrusion lines.

Produces plastic films on a smaller scale and delivering precise and rapid testing performance and development.

### Features

- Broad range of materials compatibility
- Space-saving design
- Spiral mandrel with annular die lip
- High-efficiency cooling ring for optimal film quality
- Precise nip roll control over film thickness
- Pneumatic expansion shaft for film wind-up
- User-friendly computerized interface

### Options

- Anti-Static Bar

### Materials

- Polyethylene (PE)
- Blends and Composites
- Biodegradable Polymers

### Applications

- Small Batch Samples
- Research and Development
- Testing New Resin Formulations
- Hands-on Extrusion Learning to Students



Type LMF-200

### Technical Specifications

Mini Scientific Blown Film Extrusion Line		LMF-200
Maximum Film Lay Flat Width	mm	180
Minimum Film Thickness <small>(depending on resin type)</small>	µm	20
Standard Film Die Diameter <small>(others on request)</small>	mm	Ø 25
Die Lip Gap	mm	0.8
Height from Die to Nip-Roll	mm	750
Maximum Line Speed	m/min	10
Dimensions (L x W x H)	m	1.38 x 0.90 x 1.67

**NOTE** Customization available upon request

### 🏭 Laboratory Scientific & Pilot

Our Laboratory and Pilot Blown Film Lines offer superior solutions for both research and production-scale operations. These machines are designed to deliver exceptional performance in resin utilization, color dispersion, and high output capacities.

#### ⚙️ Features

- Consistent film thickness
- High-quality film output
- Optimized resin utilization
- Simple user-friendly controls
- Flexible setup and easy operation
- Built to withstand highly demanding production
- Optimized air cooling for film clarity & strength

With extruder sizes designed to handle a broad range of film widths and materials, they are ideal for developing and testing new formulations before scaling up to full production.

#### 📝 Options

- Gel and Spot Counting Detection System
- Stabilizing Teflon Film Guide Cages
- Oscillating Nip Roll Haul-Off System
- Film Edge-Cutter with Edge-Trim Cassettes
- Bubble Size Control with Air Inflation and Exhaust
- Optional Die Mandrel and Lip Ring for other Diameters



Type LF-250 and Type LE20-30/C

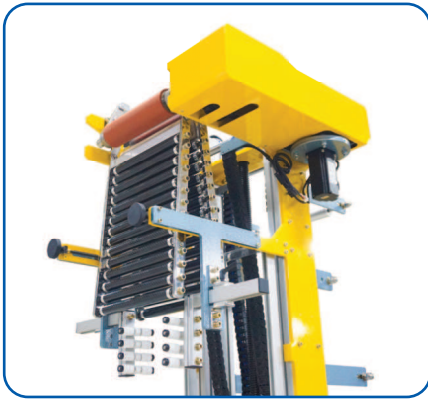

**Teflon A-Frame**



**Splitting Knives**



**Gel and Spot Counting Detection System**

**Options**

- Steel Platform
- Splitting Knives
- Anti-Static Bar
- Water-Cooled Nip Rolls
- Nip Roll with Tension Control
- Wind-Up System
  - Two-Station Surface Wind-Up System
  - Digital Electronic Film Counter System
  - Constant Film Tension Wind-Up
  - Air Expansion Wind-Up Shaft
  - Fully Automatic Film Roll Changer with Surface Wind-Up System
- Teflon Collapsing A-Frame
- Fully Computerized Controls
- Automatic Web Guide System
- Gel and Spot Counting Detection System



**Two-Station Constant Film Tension Wind-Up System**

**Materials**

- Polyamides (PA 6, PA 6,6)
- Thermoplastic Elastomer (TPE)
- Polymer Blends and Composites
- Polyolefin (LLDPE, LDPE, HDPE, PP)
- Biodegradable Polymers (TPS, PLA, PBAT, etc.)

**Applications**

- Research and Development
- Testing New Resin Formulations
- Grocery Bags, Shrink Wrap, and Food Packaging
- Retail Bags, Freezer Bags, and Agricultural Films
- Shrink Films, Cling Films, and Packaging for Perishable Goods
- Food Packaging, Vacuum Bags, and Pharmaceutical Packaging

**Technical Specifications**

Blown Film Extrusion Lines		Laboratory Scientific			Pilot
		LF-250	LF-400	LF-600	LF-700 LF-800 LF-1000
Maximum Film Lay Flat Width	mm	200	350	550	Design upon request
Minimum Film Thickness <small>(depending on resin type)</small>	µm	20			
Standard Film Die Diameter <small>(others on request)</small>	mm	Ø 30	Ø 50	Ø 80	
Die Lip Gap	mm	0.8	0.8	0.8	
Height from Die to Nip-Roll	mm	1000	1200	2000	
Maximum Line Speed	m/min	25	35	35	
Dimensions (L x W x H)	m	1.29 x 0.72 x 2.40	1.45 x 0.87 x 2.40	1.76 x 1.25 x 3.20	

**NOTE** Customization available upon request

# Blown Film Multilayer Co-Extru

Our Multilayer Blown Film Extrusion Lines can produce films ranging from 2 layers up to 11 layers, enabling a wide array of film structures. The customizable layers allow for quick and straightforward adjustments, like easily switching from 7 layers to 5 or 3 layers. This versatility makes our extrusion lines perfect for meeting diverse industrial requirements.

Equipped with a pancake die design, these lines ensure easy maintenance and flexibility. The line is capable of handling a wide range of diverse polymers to create films with unparalleled properties from enhanced barrier protection to superior strength and flexibility. Our solutions are tailored to meet the exact demands of your industry.

## 🔧 Ultramicro Scientific Co-Ex

Compact and high-precision machine designed for producing small-scale, multilayer films offering the same level of precision and control of larger blown film lines in a much smaller footprint.

With its high degree of control over each layer thickness, material composition, and bonding interfaces, this makes it ideal for research and development, laboratory testing, and sample production.



Type LUMF-150/COEX

### ⚙️ Features

- User-friendly control system
- Accurate layer thickness control
- Consistent high-quality film output
- Low initial investment and operating costs
- Easy installation with small space requirements
- Quick film production of small batches for testing

### 📝 Options

- 3 or 5-Layer Films
- Two-Station Wind-Up Unit

### Technical Specifications

Ultramicro Scientific Blown Film COEX Line		LUMF-150 /COEX
Maximum Film Lay Flat Width	mm	130
Minimum Film Thickness <small>(depending on resin type)</small>	µm	20
Standard Film Die Diameter <small>(others on request)</small>	mm	Ø 28
Die Lip Gap	mm	1.5
Height from Die to Nip-Roll	mm	700
Maximum Line Speed	m/min	5
Dimensions (L x W x H)	m	1.46 x 1.30 x 1.68 (3-layer)

# Extrusion Lines

## Mini Scientific Co-Ex

Practical solution designed to excel in delivering 3 to 5 layers of exceptional film quality, it offers outstanding versatility and precision in creating innovative films with tailored properties by combining multiple resin layers.

The Mini Scientific Blown Film Co-Ex Line is ideal for small-scale commercial manufacturing, educational purposes, and pilot production runs, delivering the perfect balance of size, capacity, and functionality.

### Features

- Space-saving design
- Optimum dual channel air ring
- Fully computerized central control
- Oscillating tower for an even film roll wind-up
- High cooling efficiency and film bubble stability
- In-house design weighing hoppers for precise feeding

### Options

- Anti-Static Bar
- 3 or 5 Layers Film Configuration
- Die Lip Ring and Core Mandrel Set
- Pancake Die Configuration Assembly

### Materials

- Polyamides (PA 6, PA 6,6)
- Polymer Blends and Composites
- Polyolefin (LLDPE, LDPE, HDPE, PP)
- Biodegradable Polymers (TPS, PLA, PBAT, etc.)

### Applications

- Agriculture Mulch Films
- Packaging Development and Innovation
- Barrier Films for Food Packaging, Pharmaceutical Packaging
- Additive Evaluation for Colorants, Fillers and Film Performance Inhibitors



Type LMF-200/COEX

### Technical Specifications

Mini Scientific Blown Film COEX Line		LMF-200 /COEX
Maximum Film Lay Flat Width	mm	180
Minimum Film Thickness <small>(depending on resin type)</small>	µm	20
Standard Film Die Diameter <small>(others on request)</small>	mm	Ø 40
Die Lip Gap	mm	1.5
Height from Die to Nip-Roll	mm	1000
Maximum Line Speed	m/min	10
Dimensions (L x W x H)	m	2.30 x 1.50 x 2.02 (3/5-layer)

**NOTE** Customization available upon request

### 🏭 Laboratory Scientific & Pilot Co-Ex

Our Laboratory and Pilot Blown Film Co-Extrusion Lines offer a wide range of sizes and can produce films with up to 11 layers. Fully customizable with features such as automatic bubble size control, corona treatment, anti-static systems, and splitting knives, these lines maximize performance and versatility.

They allow for the creation of films with high barrier properties, exceptional mechanical strength, and superior optical qualities, providing ultimate flexibility and precision for both research and small-scale production.

#### ⚙️ Features

- Motorized tower height adjustments
- Freestanding central co-extrusion control cabinet
- Surface wind-up system with easily removable bobbins
- Duplex airflow design for efficient film cooling and solidification
- Customizable tower configurations according to layer and output required
- Pneumatic nip rolls with wear-resistant rubber and polished chrome surfaces
- In-house pancake die production and design consultation with Canadian expert
- Film bubble-stabilizing cage with Teflon-coated rollers for consistent film bubble shape and control

#### 📄 Options

- Splitting Knives
- Anti-Static Bar
- Corona Treater
- Die Core Mandrel
- Teflon Stabilizing Cage
- Automatic Web Guide System
- Platforms for Large Film Towers
- Chiller for Air Ring
- Nip Rolls with Tension Control
- Edge-Cutter with Edge-Trim Cassettes



LF-600/COEX with 3 units LE30-30/C

## Options

- Die Melt Temperature and Pressure Readout
- Automatic Bubble Size Control with Air Inflation
- Bubble Size Control with Air Inflation and Exhaust
- Multilayer Pancake Film Blowing Die Configuration
- Oscillating Nip Roll Haul-Off with A-Frame Collapsing Gate
- Wind-Up Systems
  - Two-Station Surface Wind-Up System
  - Digital Electronic Film Counter System
  - Constant Film Tension Wind-Up
  - Air Expansion Wind-Up Shaft
  - Fully Automatic Film Roll Changer with Surface Wind-Up System



Oscillating System



LF-400/COEX with 5 units LE25-30/C

## Materials

- Polyolefin (LLDPE, LDPE, HDPE, PP)
- Polyamides (PA 6, PA 6,6)
- Thermoplastic Elastomer (TPE)
- Ethylene Vinyl Acetate (EVA)
- Ethylene Vinyl Alcohol (EVOH)
- Polymer Blends and Composites
- Biodegradable Polymers (TPS-based Materials, PLA, PBAT, etc.)

## Applications

- Agriculture Mulch Films
- Enhancing Interlayer Adhesion
- Multilayer Films for Protective and Flexible Packaging
- Process Parameter and Layer Thickness Optimization
- Equipment and Process Scaling for Commercialization
- Optimizing Barrier, Clarity, and Opacity Properties of Films
- Barrier Films for Food Packaging and Pharmaceutical Packaging

## Technical Specifications

Blown Film COEX Lines		Laboratory Scientific		Pilot			
		LF-250/COEX	LF-400/COEX	LF-600/COEX with platform	LF-700/COEX with platform	LF-800/COEX with platform	LF-1000/COEX with platform
Maximum Film Lay Flat Width	mm	200	350	550	650	750	950
Minimum Film Thickness (depending on resin type)	µm	20					
Standard Film Die Diameter (others on request)	mm	Ø 20 to 40	Ø 40 to 75	Ø 80 to 120	Ø 130 to 190		
Die Lip Gap	mm	1.5					
Height from Die to Nip-Roll	mm	1000	1200	2000	3700	3800	4000
Maximum Line Speed	m/min	25	35				
Dimensions (L x W x H)	m	Depends upon design					

**NOTE** Customization available upon request

## Compact Scientific Co-Ex

A cost-effective alternative to conventional Blown Film Co-Ex Lines capable of producing 3, 5, and 7 film layers. Featuring lowboy extruders connected to a pancake die and a rotating nip-roll wind-up system that oscillates 360° around the die assembly, ensuring consistent film quality.

### Options

- Chiller for Air Ring
- Adjustable Die Lip Diameter & Mandrels
- Modular Die Assembly with 3, 5, or 7 Layers
- Loss-In-Weight Hopper
- Rotary Union Joints & Flexible Hoses for Water Cooling of Nip Rolls

### Features

- Dual-channel air ring for optimal cooling
- Low-friction rails with easy access to die & air ring
- Minimal floor space, sturdy base, clean appearance
- User-friendly controls with real-time data monitoring
- Lowboy extruders aligned with low-height die assembly
- Binary distribution & spiral flow channels for uniform layer thickness
- Air streams fine-tune controls for bubble stability, blow-up ratio, & frost line height

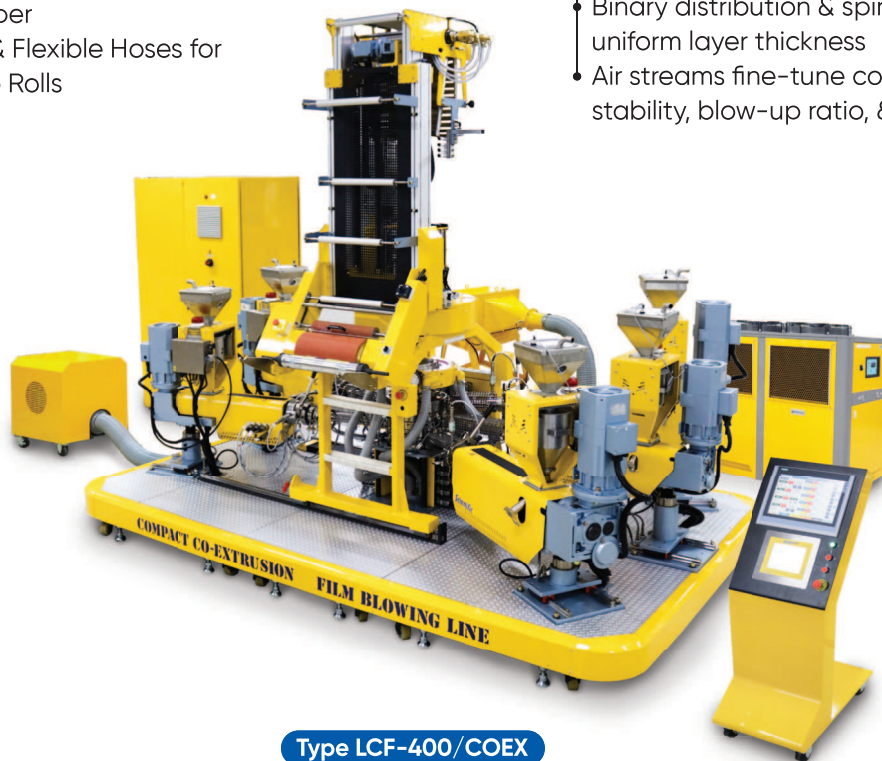

Type LCF-400/COEX

### Materials

- Polyolefin (LLDPE, LDPE, HDPE, PP)
- Polyamides (PA 6, PA 6,6)
- Thermoplastic Elastomer (TPE)
- Ethylene Vinyl Acetate (EVA)
- Ethylene Vinyl Alcohol (EVOH)
- Polymer Blends and Composites
- Biodegradable Polymers (TPS, PLA, PBAT, etc.)

### Applications

- Film Layer Structure Analysis
- Additive Dispersion Experiments
- Optimizing Processing Conditions
- Polymer Compatibility & Interfacial Adhesion
- Developing Barrier, High-Performance & Specialty Films

### Technical Specifications

Compact Scientific Blown Film COEX Line		LCF-400 /COEX
Maximum Film Lay Flat Width	mm	350
Minimum Film Thickness <small>(depending on resin type)</small>	µm	20
Standard Film Die Diameter <small>(others on request)</small>	mm	Ø 40 to Ø 75
Die Lip Gap	mm	1.5
Height from Die to Nip-Roll	mm	1200
Maximum Line Speed	m/min	35
Dimensions (L x W x H)	m	4.46 x 2.26 x 2.95 (5-layer)

**NOTE** Customization available upon request

# Special Blown Film Extrusion Lines

## Liquid Crystal Polymers (LCPs) Blown Film Line

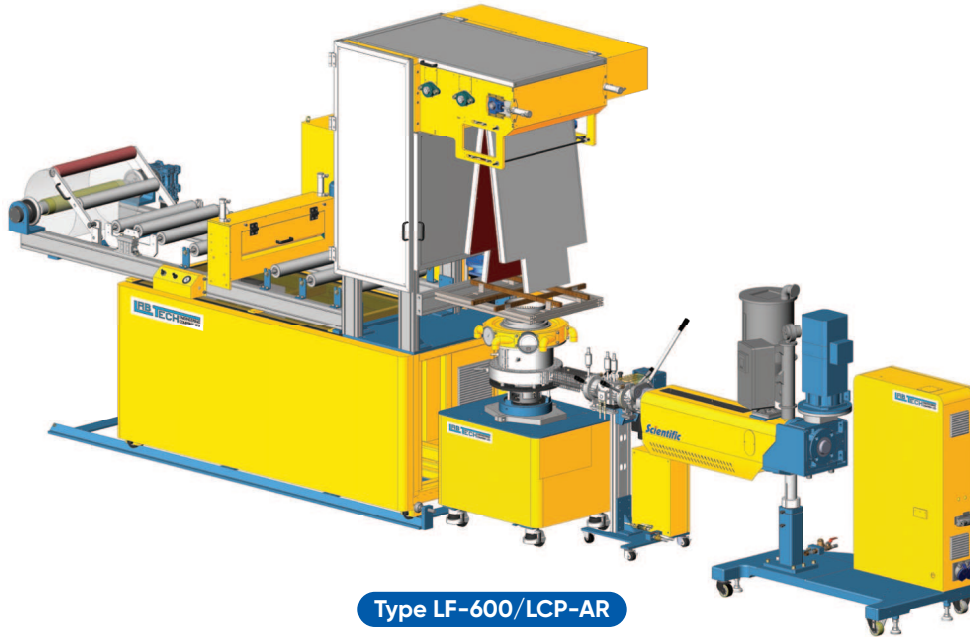

Type LF-600/LCP-AR

Labtech has developed a Blown Film Extrusion Line specifically engineered for processing Liquid Crystal Polymers, producing LCP films renowned for their high-barrier performance and superior mechanical properties in both the machine (MD) and transverse (TD) directions.

The line features a unique rotating die to reduce the high anisotropy inherent to LCP materials, resulting in more consistent film properties. It also includes a specially designed A-frame and downstream unit that further minimizes wrinkles, ensuring smooth and uniform film production.

### Features

- Streamlined design for easy access and safe operation
- Tri-rotating die technology for precise multi-axial orientation of the LCP melt
- The annealing downstream unit gradually cools the film and eliminates residual stress
- Haul-off tower nip rolls with water-tempered silicone rubber and steel rollers to relax the film

### Materials

- Liquid Crystal Polymer (LCP)

### Applications

- Microelectronics Packaging
- Anti-Corrosive Liners and High-Barrier Films
- Electrical Circuit Boards and Protective Films

Technical Specifications		
Special LCP Blown Film Extrusion Line		LF-600/LCP-AR
Roll Width	mm	600
Tri-Rotating LCP Film Die Diameter	mm	Ø 80 and Ø 110
Die Lip Gap	mm	0.4 to 0.8
Maximum Line Speed	m/min	35

**NOTE** Customization available upon request

# Special Blown Film Extrusion

## Water Quenching Blown Film Line

Labtech's Downward Blown Film Extrusion Line with instant Water Quenching System is a groundbreaking technology that has transformed the plastics industry. By rapidly cooling the extruded film with a water curtain, this innovative process delivers exceptional film transparency, quality and performance.

### Features

- Stainless steel contact parts
- Rapid water quenching technology
- Height-adjustable water quenching rings
- Reduced shrinkage and better film flatness
- Superior film clarity and enhanced film strength
- User-friendly controls with precise adjustment of film thickness, bubble size, and cooling rate

### Options

- Water Chiller Unit
- Fully Computerized Controls
- Available in Co-Extrusion Line
- Air Expansion Wind-Up Shaft
- Die Melt Temperature and Pressure Readout
- Die Mandrel and Lip Ring for other Diameters



Type LWQF-400

### Materials

- Polyamide (Nylon)
- Polypropylene (PP)
- Ethylene Vinyl Acetate (EVA)
- Polyethylene (PE)
- Polyethylene Terephthalate (PET)

### Applications

- High-Clarity Packaging
- Medical and Hygiene Films

### Technical Specifications

Water Quenching Blown Film Extrusion Line		LWQF-400
Maximum Film Lay Flat Width	mm	350
Standard Film Die Diameter	mm	Ø 50 to Ø 75
Die Lip Gap	mm	0.8
Maximum Line Speed	m/min	35
Dimensions (L x W x H)	m	4.90 x 2.40 x 2.76

**NOTE** Customization available upon request

# Lines

## Double-Bubble Blown Film Line

Labtech's Downward Double-Bubble Blown Film Extrusion Line is designed to produce high-quality films with superior clarity, strength, and barrier properties. This advanced system utilizes a two-step process: the primary bubble forms the initial film, which is then reheated and expanded in the secondary bubble stage. This method ensures uniform thickness and excellent film properties.

Ideal for producing shrink films, barrier films, and specialty packaging materials, the double-bubble extrusion line offers precise control over film characteristics, making it a versatile and efficient solution for various industrial applications.

### Features

- User-friendly controls
- Stable bubble formation
- Stainless steel contact parts
- Two-level downstream guide rollers
- Annealing chamber reheating system
- Precise control in stretchable temperature

### Options

- Water Chiller Unit
- Fully Computerized Controls
- Available in Co-Extrusion Line
- Air Expansion Wind-Up Shaft
- Die Melt Temperature and Pressure Readout
- Die Mandrel and Lip Ring for other Diameters

### Materials

- Polypropylene (PP)
- Polyamide (Nylon)
- Polylactic Acid (PLA)
- Polyvinylidene Chloride (PVDC)

### Applications

- Shrink Films and Bags
- Films with Improved Clarity
- High-Barrier Packaging
- Specialty Films



Type LDBBF-400

Technical Specifications		
Double-Bubble Blown Film Extrusion Line		LDBBF-400
Maximum Film Lay Flat Width	mm	300
Standard Film Die Diameter	mm	Ø 50 to Ø 75
Die Lip Gap	mm	0.8
Maximum Line Speed	m/min	35
Dimensions (L x W x H)	m	2.10 x 1.13 x 2.61

**NOTE** Customization available upon request

# Available Setups for Blown Film

## Blown Film Dies

### Pancake Die

Consists of stacked plates or “pancakes”, each with its own spiral flow channel system within each plate to ensure even melt distribution in producing multilayer blown film.

#### Features

- Customizable up to 11 layers
- Precise temperature control for each layer
- Easily configurable for fewer layers by changing the postcore
- Compatible with Y-adaptors, allowing a single extruder to feed the same resin into two layers

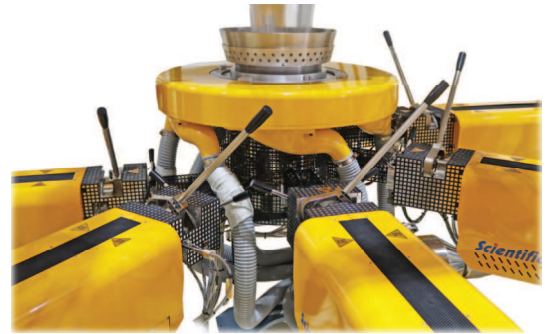

### Spider Die

Spider Die is specifically advantageous for producing PVC films, where the design minimizes shear stress, reducing the risk of material degradation due to PVC's sensitivity to high temperatures.

#### Features

- Design allows easier manufacturing and maintenance
- Good flow distribution provides good film thickness uniformity, particularly in smaller extrusions
- Balanced internal pressure distribution improves the stability of the film bubble



### Tri-Rotating Die

Tri-Rotating Die is a special die designed for Liquid Crystal Polymer (LCP). It is equipped with three internal mandrels rotating in opposite directions to create the necessary transverse shear stresses across the melt for a multi-axial symmetrical orientation of the LCP melt. This design ensures a multi-axial symmetrical orientation of the LCP melt, helping to prevent film curling during the cooling process.

#### Features

- Mounted on a cart with lockable casters for easy mobility
- Equipped with servo motors and gears to control the rotation of the three rotors/cylinders
- Middle rotor rotates in the opposite direction and at the same speed as the inner and outer rotors, balancing the residual stress and preventing film distortion.
- Dual flow channels with one channel between the outer and middle cylinders, and another between the inner and middle cylinders

# Extrusion Lines

## Winders

### Air Expansion Shaft System

Allows quick roll mounting and secure gripping with 3" PVC bobbins. Compressed air expands the internal elastomeric elements for firm holding, while releasing the air collapses the shaft lugs for easy bobbin removal.

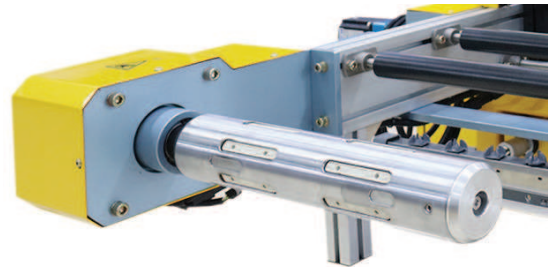

### Two-Station Constant Film Tension Winder

Provides consistent winding tension control at all times for smooth, uninterrupted roll changes, handling both continuous and individual split film winding applications.

#### Features

- Consistent film tension maintained by load cells and torque motor control
- For double-wall films, the system allows quick removal of the finished roll and replacement with a pre-mounted empty bobbin
- For single-wall films, the system simultaneously collects two slitted films from the blown film process

### Fully Automatic Film Roll Changer with Surface Wind-Up System

Designed for high-speed film production, enabling seamless roll changeovers without interrupting the process for a continuous operation.

#### Features

- Utilizes a high-friction rubber roll for efficient surface film winding
- Automatically cuts film at a preset roll length and replaces the finished roll with a new, empty bobbin without interruption
- Three-sided cover guards with large Plexiglas windows
- Electronic safety curtains and interlocked safety switches for operator protection



# Blown Film Line Sample Setups



## 🏭 Pilot Single-Layer Blown Film Line

### Type LF-600

- Fully Computerized Touchscreen Controls
- Steel Platform
- 40 mm Single-Screw Extruder
- Chiller for Air Ring
- Spiral Mandrel Die
- Teflon Film Bubble Stabilizing Cage
- Carbon Fiber A-Frame Collapsing Gate
- Water-Cooled Nip Rolls
- Wheel-Adjustable Rotary Knife Edge-Cutter with Edge-Trim Wind-Up Cassettes
- Two-Station Constant Film Tension Winder

## Pilot Three-Layer Blown Film Co-Extrusion Line

### Type LF-600/COEX

- Steel Platform
- Motorized Tower Height Adjustment
- 3 units of 30 mm Single-Screw Extruders with Loss-in-Weight Hoppers
- 3-Layer Pancake Die
- Duplex Air Ring with Chiller
- Water Cooling of the Nip Rolls with Rotary Joints
- Blown Film Splitting Unit
- Two-Station Constant Film Tension Wind-Up
- Central Control Cabinet with Computerized Touchscreen Controls for Loss-In-Weight Hoppers



8.07 m

4.49 m

# Cast Film and Sheet Single-La

Labtech Engineering offers a comprehensive range of Cast Film and Sheet Extrusion systems from small-scale ultramicro and laboratory experiments to large-scale pilot production designed to meet diverse production solutions.

Our systems use advanced technology and innovative techniques to ensure high-quality results, whether you're producing films with multiple layers or a single layer.

## Ultramicro Scientific

Our Ultramicro Scientific Cast Film and Sheet Extrusion Line is ideal for producing thin films with exceptional precision. Its cost-effective solution is perfect for research & trial test sampling.

These systems are ideal for creating films with consistent thickness and customizable properties while requiring only a minimal amount of material.

### Features

- Minimal material consumption
- Coat hanger flat die with adjustable lip gap
- High-quality construction for durability with easy operation and maintenance
- Roll lay-on manually controlled by handwheel for smooth film/sheet production
- Design requires minimal floor space with all components integrated into a single unit
- Tight tolerance control for consistent film quality

### Options

- 75 mm width Flat Die

### Materials

- Polyethylene (PE)
- Polypropylene (PP)

### Applications

- Hands-on Academic Training
- Sample Prototyping & Quality Control Testing
- Optimized Process Parameters for Research & Development of Film Structures



Type LUMCR-50

### Technical Specifications

Ultramicro Scientific Cast Film and Sheet Extrusion Line		LUMCR-50
Extruder Maximum Operation Temperature	°C	300
Roll Diameter (All 3 Rolls)	mm	40
Die Lip Gap Range	mm	0.1 to 0.3
Maximum Die Width	mm	Standard: 50 Optional: 75
Film/Sheet Thickness Range (depending on resin type)	µm	20 to 300
Maximum Line Speed	m/min	5
Dimensions (L x W x H)	m	1.30 x 0.70 x 1.30

# Layer Extrusion Lines

## Mini Scientific

The Mini Scientific machine is optimally designed to produce both thin films and thick sheets, offering exceptional versatility for a variety of applications in limited laboratory spaces.

Ideal for research and development, this system allows you to experiment with a wide range of materials, enabling the creation of innovative plastic films with outstanding results.

### Features

- Space-saving design for lab-scale
- Accurate control with touchscreen interface
- Downward-facing flat die with 90° adapter optimal for even very low viscosity materials
- Precise control over film thickness uniformity
- Vertically adjustable roll for minimized film neck-in
- Rubber pressing roll for optimum film-to-roll contact

### Options

- Anti-Static Bar
- Chiller for the Cast Roll
- Gel and Spot Counting Detection System
- Die Melt Temperature & Pressure Readout
- Edge-Cutter with Edge-Trim Cassettes
- Teflon Coating for the Cast Roll
- Water Tempering Unit (140 °C) for Cast Roll

### Materials

- Polyethylene (PE)
- Polypropylene (PP)
- Blends and Composites
- Biodegradable Polymers (PBAT, PLA)
- Polyethylene Terephthalate (PET)

### Applications

- Quality Control Testing
- Academic and Technical Training
- Research and Development of New Film/Sheet Materials

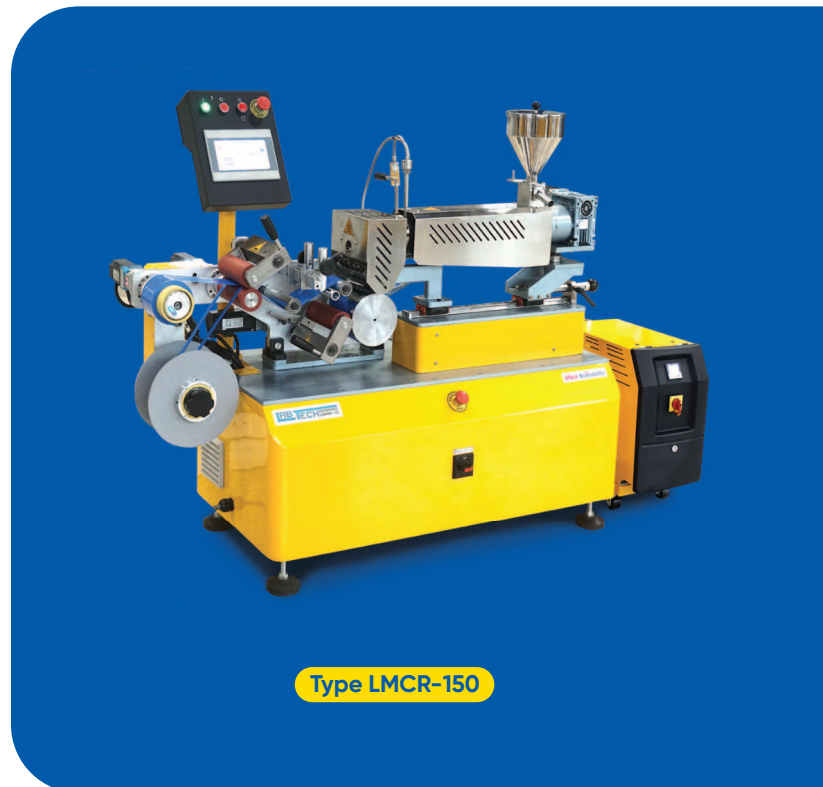

Type LMCR-150

### Technical Specifications

Mini Scientific Cast Film and Sheet Extrusion Line		LMCR-150
Extruder Maximum Operation Temperature	°C	300 (optional 400)
Roll Diameter	mm	145
Die Lip Gap Range	mm	0.3 to 2
Maximum Die Width	mm	125
Film/Sheet Thickness Range (depending on resin type)	µm	20 to 1000
Maximum Line Speed	m/min	12
Dimensions (L x W x H)	m	1.61 x 0.81 x 1.18

**NOTE** Customization available upon request

## Laboratory Scientific

Our Benchtop and Laboratory Cast Film and Sheet Extrusion Lines are versatile and compact solutions designed for research and development. These systems feature a calendaring unit with three rolls, available in both standard and large-roll sizes for handling heavy-duty applications. They are used for producing either very thin-walled films or heavy-wall sheets.

The standalone unit is compatible with various sizes of extruders and can produce films with widths ranging from 100 to 350 mm, with precise control over thickness and dimensions. The line is capable of processing a wide range of materials, making it ideal for experimentation and development of new film and sheet products.



Type LBCR-150

### Options (Lab & Pilot Lines)

- Air knife for film cooling
- Fully Computerized Controls
- Wide Size Range of Extruder Attachments
- Silicone Rubber/Carbon Black Teflon covered Rollers
- Water (140 °C) and Oil (200/300 °C) Tempering Units
- Vacuum Box with Blower
- Edge Pinners
- Anti-Static Bar
- Infrared Heater
- Corona Treater
- Gel and Spot Counting Detection System
- Wheel Adjustable Rotary Knife Edge-Cutter
- Edge-Cutter with Edge-Trim Cassettes
- Automatic Film Tension Control
- Winder Systems:
  - Fully Automatic Winder
  - Two-Station Surface Winder
  - Air Expansion Shaft
- Unwinder Systems:
  - Economy Laminating Unwinder
  - Unwinder with Fully Automatic Tensioning System

### Features

- Versatile roll tilting stack position in vertical or horizontal
- Highly accurate control over film thickness and smoothness
- Accurate roll gap control and individual servo motors for rolls
- Available with die-gap fine adjustment via manually differential screws
- Rollers equipped with internal spiral channels for efficient temperature control
- Calendaring unit consists of three rolls with wide range of varying widths for different product dimensions

### Features

- User-friendly control panel
- Combined surface and center winding system
- Precise individual roll temperature control through internal cored and rotary joints
- Adjustable roll stack position in vertical or horizontal for LCR-175, LCR-300 and LCR-350

Cast Film and Sheet Extrusion Lines			LBCR-150
Extruder Maximum Operation Temperature		°C	
Roll Diameter (All 3 Rolls)	Pneumatic	mm	72.5, 145, 72.5
	Hydraulic	mm	-
Die Lip Gap Range		mm	
Maximum Die Width		mm	150
Film/Sheet Thickness Range (depending on resin type)		µm	
Maximum Line Speed		m/min	
Dimensions (L x W x H)		m	2.03 x 0.86 x 1.36

**NOTE** Customization available upon request

## Pilot Combined Extrusion and Calendering Line

The pilot-scale Cast Film and Sheet Extrusion Line provides a bridge between small-scale testing and full-scale production operations.

The rolls are equipped with heavy-duty hydraulic lay-on system and a motorized tilting mechanism that allows for configuring the rollers at horizontal, vertical, or 45° angle.

Labtech also offers a diverse range of die types and calendering units, enabling reliable testing and parameter optimization across various product types and thicknesses.



Type LCCR-600/C

### Materials

- Thermoplastic Polyurethane (TPU)
- Polyvinyl Chloride (PVC)
- Polyamides (PA 6, PA 6,6)
- Polymer Blends and Composites
- Polyolefins (LLDPE, LDPE, HDPE, PP)
- Biodegradable Polymers (TPS, PLA, PBAT, etc.)

### Applications

- Process Optimization
- Education and Training
- Embossing or Texturing Rollers
- Film/Sheet Property Evaluation
- Rubber, Leather, or Fabric Lamination
- Various Thickness in Film/Sheet Production
- Quality Control and Product Development
- Packaging Material Development and Testing

### Technical Specifications

Laboratory Scientific			Pilot				
LCR-175	LCR-300	LCR-350	LCCR-500	LCCR-600	LCCR-700	LCCR-1000	LCCR-1200
			300 (optional 400)				
145	72.5, 145, 72.5		-	-	-	-	-
145	145		175		200	250	
			0.3 to 2.0				
175	300	350	500	600	700	1000	1200
			20 to 1000				
15			25				
2.66 x 1.06 x 1.48	2.77 x 1.24 x 1.86	2.43 x 1.29 x 1.86	4.45 x 1.44 x 1.94	4.52 x 1.50 x 2.02	4.48 x 1.60 x 1.94	5.76 x 2.30 x 1.81	6.00 x 2.43 x 2.00

# Cast Film and Sheet Multilayer

Labtech Engineering offers a Cast Film Line designed for processing various resins and creating co-extruded layers of thin films and sheets.

Our technology enables the creation of multilayer structures that enhance film performance by combining different materials with specific properties like barrier and strength.

## Ultramicro Scientific Co-Ex

The Ultramicro Cast Film and Sheet Co-Ex Line is capable of processing various resins and creating 3-layer co-extruded ultrathin films and sheets ideal for a wide range of applications, including medical devices, electronics, and packaging.

### Features

- Simplified operation for reduced operator error
- Chill roll lay-on force handwheel adjustment for fine-tuning film thickness and surface quality
- Versatile 3-layer configuration for co-extrusion, easily convertible to 2-layer
- 3-layer feedblock with A-B-A configuration
- Efficient temperature control for precise film formation
- Small space requirements for reduced operational cost
- Produces multilayer films & sheets with consistent thickness

### Options

- 3-Layer Film with 2 or 3 Extruder Configuration
- Flat Die with 75 mm Width

### Applications

- Developing Films with Specific Functional Properties (conductivity, heat resistance, etc.)
- Quality Control Testing and Academic Demonstration
- Material Research for Polymer Blends and Composites
- Trial Sampling for Customers



Type LUMCR-50/COEX

### Technical Specifications

Ultramicro Scientific Cast Film and Sheet COEX Line		LUMCR-50/COEX
Extruder Maximum Operation Temperature	°C	300
Roll Diameter (All 3 Rolls)	mm	40
Die Lip Gap Range	mm	0.1 to 0.3
Maximum Die Width	mm	Standard: 50 Optional: 75
Film/Sheet Thickness Range (depending on resin type)	µm	15 to 300
Maximum Line Speed	m/min	5
Dimensions (L x W x H)	m	1.51 x 0.99 x 1.17

# Co-Extrusion Lines

## Mini Scientific Co-Ex

With its three mini extruders, this mini space-saving machine is designed for developing multilayer films and sheets, offering quick production solution of film samples and conduct in-depth analysis for efficient research.

Its user-friendly interface and efficient design ensures users to focus on exploring new polymer combinations, optimize film properties, without the complexities of large-scale production.

### Features

- Very steady and even film pull of rubber haul-off nip roll from the chill roll stack
- Vertically and horizontally adjustable chill roll to control gap and reduce film neck-in
- Co-extrusion feedback dividing resin flow from each extruder into perfect "sandwich" layers
- 3-layer feedback configurable to A-B-C (3-layer film) or A-B-C-B-A (5-layer film) structure
- Flat coat hanger die for even layer distribution from the feedback

### Options

- Loss-In-Weight Computerized Hopper Feeder for Individual Layer Thickness Control and Distribution to the Die Assembly
- Edge-Cutter with Edge-Trim Cassettes
- Die Melt Temperature and Pressure Readout
- Flat Coat Hanger Die with Max Temperature of 400 °C
- Anti-Static Bar
- Water Tempering Unit (140 °C) for Cast Roll

### Materials

- Polyethylene (PE)
- Polypropylene (PP)
- Blends and Composites
- Biodegradable Polymers

### Applications

- Developing Films with specific Functional Properties (Conductivity, Heat Resistance, etc.)
- Quality Control Testing and Academic Demonstration
- Material Research for Polymer Blends and Composites



Type LMCR-150/COEX

Technical Specifications		
Mini Scientific Cast Film and Sheet COEX Line		LMCR-150/COEX
Extruder Maximum Operation Temperature	°C	300 (optional 400)
Roll Diameter	mm	145
Die Lip Gap Range	mm	0.3 to 2
Maximum Die Width	mm	125
Film/Sheet Thickness Range (depending on resin type)	µm	20 to 1000
Maximum Line Speed	m/min	12
Dimensions (L x W x H)	m	2.10 x 1.10 x 1.70

**NOTE** Customization available upon request

## Laboratory Scientific Co-Ex

Designed to offer a laboratory-scale solution for the fast development and testing of cast film and sheet materials.

This versatile line is capable of create highly customized films and sheets up to 9 layers.

### Features

- Standard vertical roll stack with horizontal extruder-die connection
- Rubber nip rolls for steady film pulling
- Combined surface and center winding system
- Pneumatic nip control for even thickness adjustment
- Easy maintenance access with movable chill roll attachment
- Calendering unit with top polishing, center, and lower chill rolls

### Materials

- Polyurethanes (TPU)
- Polyvinyl Chlorides (PVC)
- Styrene Polymers (PS, ABS)
- Polyamides (PA 6, PA 6.6, etc.)
- Thermoplastic Elastomers (TPE)
- Polymer Blends and Composites
- Polyolefin (LLDPE, LDPE, HDPE, PP)
- Biodegradable Polymers (TPS, PLA, PBAT, etc.)



Type LCR-175/COEX

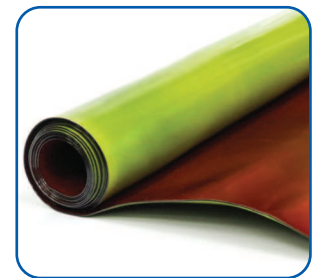

Multilayer TPU sheet

### Options (Lab & Pilot Lines)

- Fully Computerized Controls
- Wide Size Range of Extruder Attachments
- Silicone Rubber/Carbon Black Teflon covered Rollers
- Water (140 °C) and Oil (200/300 °C) Tempering Units
- Vacuum Box with Blower
- Air knife for instant melt contact without air entrapment
- Edge Pinner
- Anti-Static Bar
- Infrared Heater
- Corona Treater
- Gel and Spot Counting Detection System
- Wheel Adjustable Rotary Knife Edge-Cutter
- Edge-Cutter with Edge-Trim Cassettes
- Automatic Film Tension Control
- Winder Systems:
  - ↳ Fully Automatic Winder
  - ↳ Two-Station Surface Winder
  - ↳ Air Expansion Shaft
- Unwinder Systems:
  - ↳ Economy Laminating Unwinder
  - ↳ Unwinder with Fully Automatic Tensioning System

Cast Film and Sheet COEX Lines			LCR-175/COEX
Extruder Maximum Operation Temperature	°C		
Roll Diameter (All 3 Rolls)	Pneumatic	mm	145
	Hydraulic	mm	
Die Lip Gap Range	mm		
Maximum Die Width	mm		175
Film/Sheet Thickness Range (depending on resin type)	µm		
Maximum Line Speed	m/min		
Dimensions (L x W x H)	m		2.66 x 1.06 x 1.48

**NOTE** Customization available upon request

## Pilot Combined Co-Ex and Calendering Line

Engineered for versatile multilayer film and sheet production, this line offers customizable options for high-speed.

Efficient production of top-quality multilayer films and sheets in various materials, thicknesses, and structures.



Type LCRHS-600/COEX

### Applications

- Film Structure and Barrier Analysis
- Small-Scale Film Production Samples
- New Film-Based Product Development
- Quality Control for Product Consistency
- Research Support for Scientific Publications
- Process Optimization and Scaling Operations
- Embossing, Coating, Lamination Applications
- Defect Analysis and Specification Verification

### Features

- Large chill roll diameter for rapid film cooling
- Individually driven nip-rolls for precise control
- Tilttable rollstack for versatile film production
- High hydraulic force for smooth films and sheets
- Independent roll temperature regulation for accuracy
- Optimized die and feedback design to prevent resin degradation

### Technical Specifications

Laboratory Scientific		Pilot				
LCR-300/COEX	LCR-350/COEX	LCCR-500/COEX	LCCR-600/COEX	LCCR-700/COEX	LCCR-1000/COEX	LCCR-1200/COEX
72.5, 145, 72.5		300 (optional 400)				
145		-	-	-	-	-
		175		200	250	
0.3 to 2.0						
300	350	500	600	700	1000	1200
15 to 1000						
15		25				
2.77 x 1.24 x 1.86	2.43 x 1.29 x 1.86	4.45 x 1.44 x 1.94	4.52 x 1.50 x 2.02	4.48 x 1.60 x 1.94	5.76 x 2.30 x 1.81	6.00 x 2.43 x 2.00

# Available Setups for Cast Film

The Cast Film and Sheet Extrusion Line offers a versatile range of options to meet the diverse needs of various applications. Each configuration is designed with unique features and can be tailored to produce the desired film characteristics.

By carefully selecting the appropriate components, manufacturers can create high-quality cast films that meet the specific requirements of their target markets.

## Roll Stack Types

### J-Type

Specialized design optimized for laminating operation of two simultaneous flat dies running at the same time. The close proximity between the die and the nip point improves film formation and reduce defects, this is particularly beneficial for materials with low melt strength or those that require precise control over the film's initial shape to prevent premature solidification of sensitive materials, ensuring better film quality.

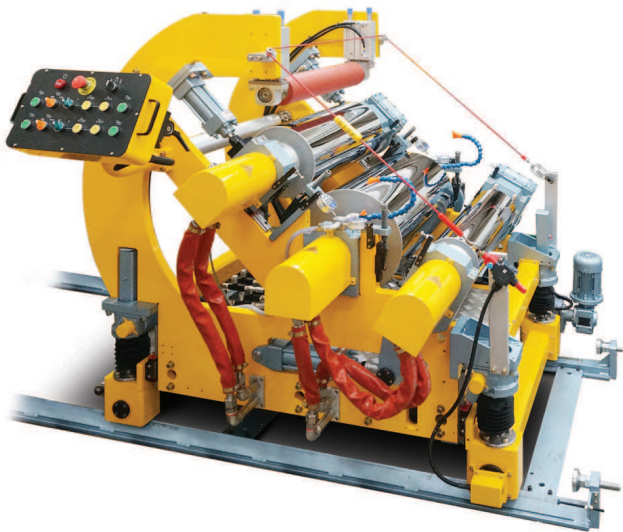

### C-Type

Features a larger enveloping angle of the rollers, which contributes to improved film cooling. The unique C-shaped chill roll stack ensures optimal contact between the film or sheet and the center and upper rolls allowing films and sheets to be produced at a very high speed while still maintaining sufficient cooling conduction from the rolls.



### Multi-Angle

Equipped with a motorized tilting mechanism, it allows the roll stack to be positioned at any angle from horizontal to vertical, or at an inclined angle of 30° or 45°, depending on request. This flexibility enables precise control over film thickness, and its versatile design accommodates a wide range of film and sheet applications, including thin to thick gauges, and medium to wide sheet widths. This unit can also handle various melt strength conditions, making it a suitable choice for diverse film production needs.



# and Sheet Extrusion Lines

## Co-Extrusion Feedblocks

Our feedblock technology is offered in several basic geometries designed to arrange and combine the melt layers before entry into a die. Its effective distribution and flow control of the molten material ensure precise layer thicknesses, enabling the creation of complex multilayer structures with superior properties.

### Standard Feedblock

The standard feedblock is designed for dies up to 300 mm and can accommodate 3 to 5 layers, with each layer being individually adjustable.

#### Features

- Quick material changeover due to very short purging time
- Precision flow control for consistent layer formation
- Versatile for various resins
- Simple to switch between layer configurations
- Supports 3-layer (A-B-C) or 5-layer (A-B-C-B-A) configurations using 3 extruders

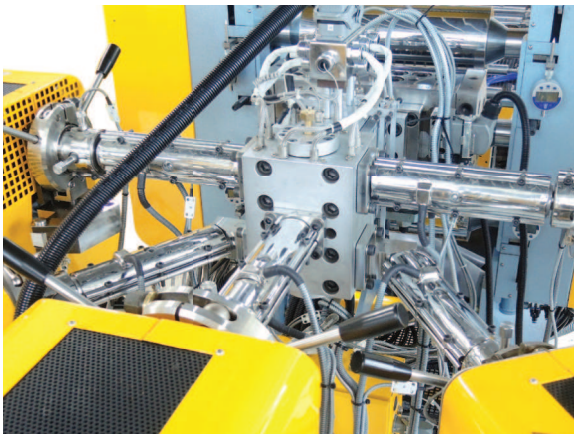
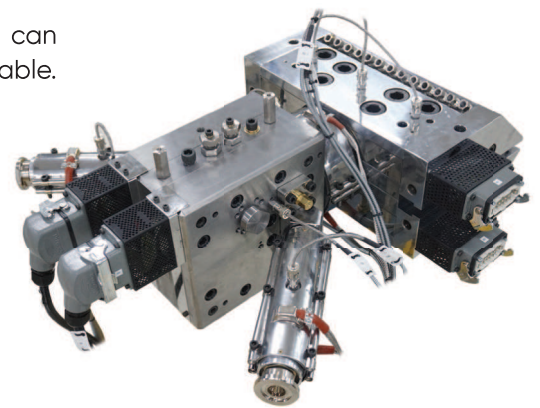

### Variable (Vane Type) Feedblock

This custom-made feedblock creates up to 9 precise layers of different resins for wide film production.

#### Features

- Flexible layer configuration with adjustable mandrel block
- Customizable design to accommodate specific resin types
- Flow channel adjustments for precise thickness control of each layer

### Fixed Geometry Feedblock

The feedblock is engineered to meet the specific demands of processing sensitive materials such as PVC, EVOH, and other heat- or shear-sensitive polymers.

#### Features

- Designed to minimize shear and thermal stress, protecting the integrity of sensitive materials
- Streamlined flow channels with fixed layer configurations
- Built up of several blocks which can be exchanged for other layer configurations

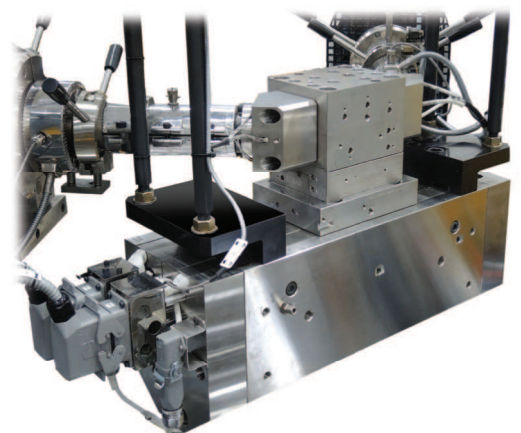

## Flat Dies

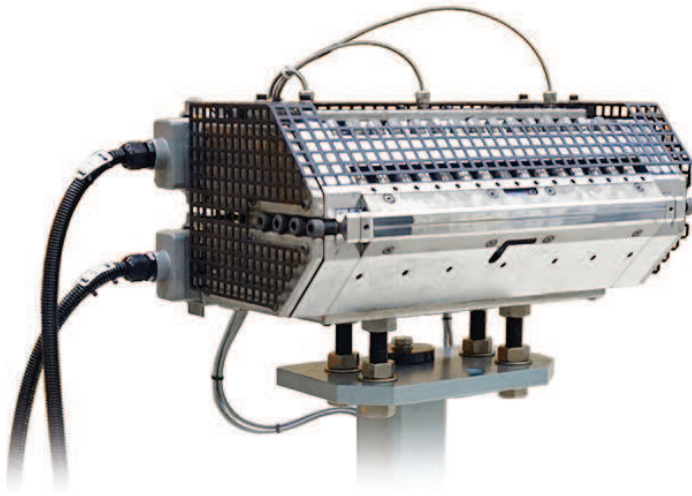

### Standard Flat Die

The Standard Flat Die is designed with adjustable lips, making it suitable for producing wide range from thin films to thick sheets thicknesses.

The die is specifically optimized for even layer distribution, ensuring consistent and uniform product quality in both single-layer and multilayer films and sheets.

For co-extrusion applications, the die is designed with a streamlined rectangular inflow ensuring each layer from the feedblock is distributed evenly over the entire width of the die, preventing any turbulence that could disrupt the layer structure and compromise product quality.

### Features

- Manually adjustable lip gap
- Individually regulated multiple heating zones
- Available in T Die, Coat Hanger or Fishtail Type
- Standard 300 °C and High-Temperature Version up to 450 °C
- Optionally equipped with lip heaters
- Optional interchangeable lip inserts
- Customizable design for specific resin
- Durable construction with various surface treatments

### Co-Extrusion Multi-Manifold Die

The Co-Extrusion Multi-Manifold Die is an advanced tool designed for producing multilayer films with exceptional precision and control.

Constructed from high-performance steel, the die features multiple interconnected coat hanger dies, allowing for precise control of layer thickness by adjusting the extruder speed.

Unlike traditional feedblocks, which combine materials before they enter the die, the multi-manifold die has separate flow channels for each layer, enabling direct and independent layer formation within the die itself.

### Features

- The multi-manifold die allows for more complex and customizable layer configurations
- Minimizes the risk of interlayer contamination by avoiding the potential mixing of materials before they enter the die
- Enhanced layer thickness precision, providing more accurate control over thickness and material distribution of each layer

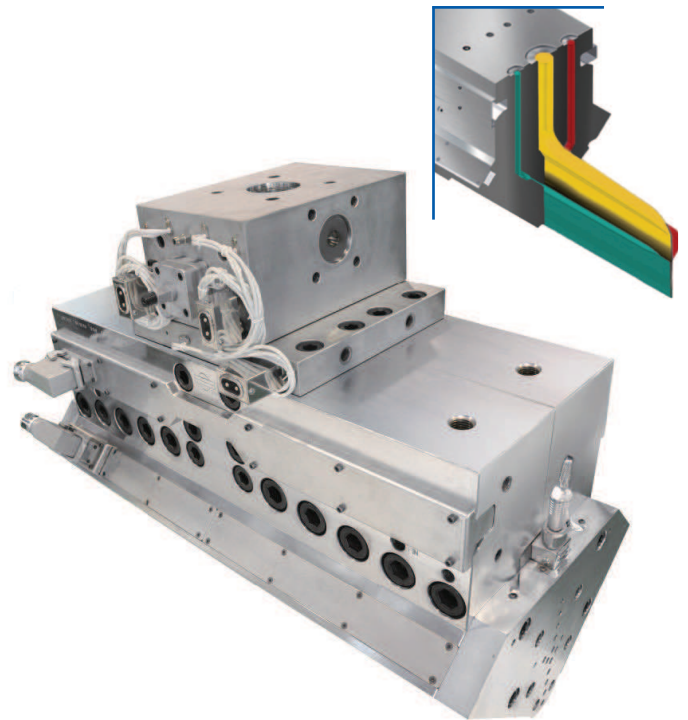

# Cast Film and Sheet Line Sample Setups

## Pilot Single-Layer Cast Film and Sheet Extrusion Line and Lamination Line with C-Type Calendering Roll Stack

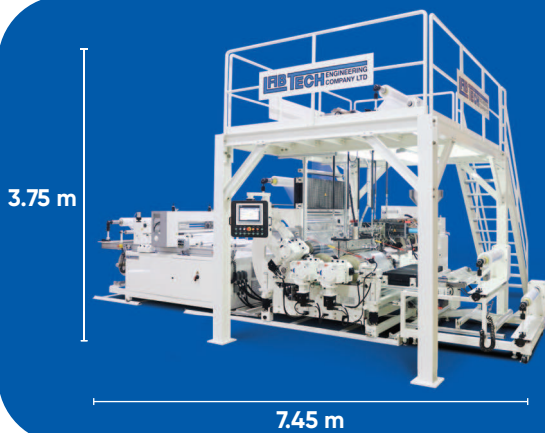

60 mm Single-Screw Extruder  
Type LE60-30

- Static Edge Pinner
- Coat Hanger Flat Die
- Vacuum Box with Blower
- Hydraulic Screen Changer

Cast Film and Sheet Line  
Type LCCR-1000-C with Platform

- C-Type Roll Stack
- 3 Oil Tempering Units
- 2 Economy Unwinders
- 2 Infrared (IR) Heater Units
- 2 Auto-Tensioning Unwinders

## Pilot 2-Layer Cast Film and Auto-Adjustable Die Lip Gap with Multi-Angle Roll Stack

2 units 25 mm Single-Screw Extruder  
Type LE25-30/C

- 350 mm Die with Automatic Lip Gap Adjustment
- 2-Layer (A-B) Feedblock
- Real-time Gel and Spot Detection and Counting System

Cast Film and Sheet Line

Type LCCR-300-SR/M/COEX

- Multi-Angle Roll Stack
- Individual Water Tempering Units for Roll Stack
- Gel and Spot Detection Counting System



## Pilot COMBI 3-Layer Cast Film and Sheet Co-Extrusion Line and 2-Layer Lamination Line with J-Type Calendering Roll Stack

3 units Combi Co- and Counter-Rotating 26 mm Twin-Screw Extruder  
Type LTECC26-44

- Chiller for Closed-Loop Water Circulating Unit
- Side-Feeder with Swivel Arm
- Gravimetric Hopper Feeders
- 2-Layer Manifold Die
- Fishtail Flat Die

Cast Film and Sheet Line

Type LCVR-350-SR

- J-Type Rollstack
- Infrared (IR) Heater Unit
- 3 Water Tempering Units
- Rotary Knife Edge-Cutter
- Automatic Film Tensioning
- Air Expansion Wind-Up Shaft
- 2 Auto-Tensioning Unwinders

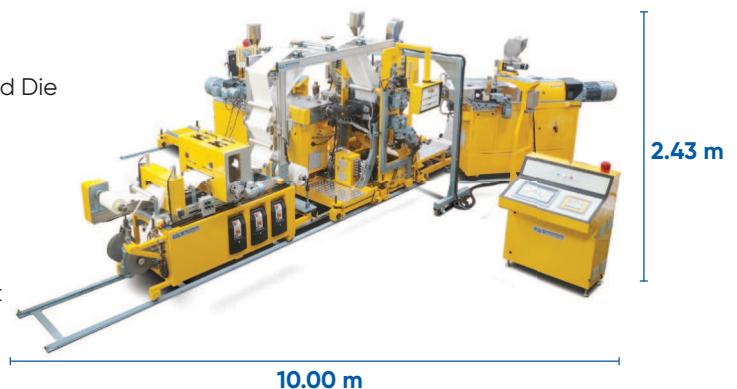

# MDO Stretching Machines

The stretching of polymer film improves their mechanical and barrier properties. Labtech Engineering offers standalone Vertical Machine Direction Orientation (MDO) Stretching attachments suitable for working in-line with Cast Film or Blown Film Extrusion Lines, or off-line with pre-made film rolls.

The machine is capable of stretching both single and multilayer films to a maximum stretching rate in the range of 10 -20 times (depending on material).

## Single Stretch Gap

The Single Stretch Gap system consists of one set of stretching rolls through which the film passes. The stretch ratio is determined by the speed differential between the front and the rear stretching rolls, their temperature, and the gap between them.

This system is ideal for films requiring basic biaxial orientation, such as those used in agricultural mulching, packaging, general-purpose applications, and lower-performance films where cost-effectiveness is a priority.



### Technical Specifications

MDO Stretching Machines		LMDO-200/145	LMDO-350/200	LMDO-350/200-2G	LMDO-400/250	LMDO-400/250-2G	LMDO-600/250	LMDO-600/250-2G
Stretching Points	number of gaps	1	1	2	1	2	1	2
Maximum Stretch Ratio	-	10:1						
Roll Diameter	mm	145	200		250			
Roll Width	mm	200	350	400		600		
Maximum Inlet Film Width	mm	150	300	350		550		
Maximum Outlet Film Speed	m/min	15	30					
Maximum Temperature of Roll Tempering Units	°C	120 (Water Tempering Unit)						

## Two Stretch Gaps

The Two Stretch Gaps system features two sets of stretching rolls, each with its own independently controlled gap. This configuration allows for a more intricate stretching process, providing greater flexibility and precise adjustments of the stretch ratio at each stage to achieve the desired film properties.

### Features

- Adjustable stretching speed and distance to obtain the required stretching rate
- Compatible with both single- and multi-layer cast and blown films
- Optimal temperature accuracy over the entire roll width with inner machined spiral roll channels for cooling and heating media

This system is ideal for films demanding high performance characteristics, such as superior optical clarity, mechanical strength, and barrier properties as well as films with complex structures or multiple layers.

- Compact vertical design to minimize floor area
- High power motors for a very constant and high torque speed during the entire operation
- Stretches film up to 20 times, depending on the film type
- Easy, safe, and practical film threading design with a handwheel



Type LMDO-350 with LF-400-COEX

### Options

- Wind-Up Systems
  - Simplified Wind-Up
  - Automatic Film Tension Control
  - Auto Turret-Revolving Winding Unit
  - Air Expansion Bobbin Wind-Up Shaft
  - Wind-Up Unit with Edge-Trimbers
- Unwinder Systems
  - Economy Unwinder
  - Unwinder with Fully Automatic Tensioning System
  - Oil Tempering Units (Maximum Temperature 180 °C)

### Materials

- Polyamide (PA)
- Polyethylene (PE)
- Polypropylene (PP)
- Polylactic Acid (PLA)
- Polyethylene Terephthalate (PET)

### Applications

- Barrier Layers in Laminated Structures
- High-Stiffness, Clear Films
- Food Wrap and Overwrap Films
- Agricultural Films for Mulching and Greenhouse Applications
- High-Barrier Films for Food Packaging and medical applications

LMDO-800/350	LMDO-800/350-2G	LMDO-1000-450	LMDO-1000-450-2G	LMDO-1000-450	LMDO-1200-450-2G
1	2	1	2	1	2
		10:1	20:1	10:1	20:1
350		450			
800		1000		1200	
750		950		1150	
50		75			

# 3D Filament Extrusion Lines

Labtech Engineering offers a comprehensive range of 3D Filament Extrusion Lines, from high-speed industrial lines to compact and mini types.

Our innovative solutions deliver precision to consistently convert plastic resin into reliable high-quality filament, a key consumable for 3D printers.

## High-Speed Laboratory Scientific

Built with advanced components fully complying with CE and other international safety standards.

Engineered for a reliable 24/7 operation to deliver optimal return on investment and produces filaments compatible with all major 3D printer brands.



3D Filament Samples



LHFA-200

LWU-130

LCAT-130

### Options

- Special Hopper Systems
  - Hopper Dryer for Moisture Removal
  - Rainbow Hopper for Customizable Filament Colors
- Vertical Filament Die with Special Vertical Calibration
- Water Bath for Low Viscosity and High Melt Flow Rate Polymers
- Co-Extrusion Filament Die for Di- and Tri-Chromatic 3D Printer Filaments
- Three-Axial Alignment Handwheel for Water Bath alignment
- Dual-Axis Laser Diameter Gauge with Closed-Loop Feedback Haul-Off System



Hopper Dryer



Rainbow Hopper

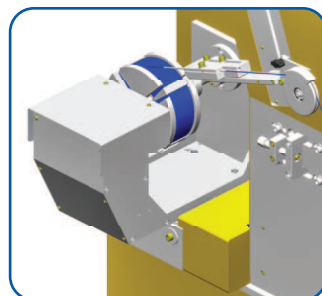

Spoolless Winder

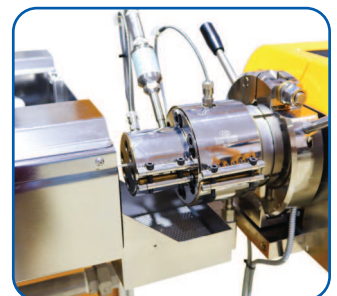

Filament Die

## Features

- 40 mm Single-Screw Extruder for up to 130 m/min production rates
- Horizontal 3D Filament Die with dual heating zones
- Triple Chamber Cooling and Calibration Bath
- 2 hot side chambers and 1 cold middle chamber
- Accumulated filament housed in a safety auto-lock transparent cabinet
- Pneumatic spool clamping system with two-hand control for safe operation
- Linear ball-screw for precise traverse and step winding motion
- Lay-on winder system for consistent filament tension
- Synchronized line speed with continuous filament accumulation
- Fast spool changeover for uninterrupted operation



## Technical Specifications

High-Speed Laboratory Scientific 3D Filament Extrusion Line				
<b>Single-Screw Extruders</b>		<b>LE40-30/C</b>		
Maximum Screw Speed	RPM	up to 200		
Maximum Barrel Temperature	°C	300 (optional 400 and 450)		
3D Filament Die Diameter	mm	1.75 and 2.85		
<b>Triple-Chamber Cooling and Calibration Filament Water Bath</b>		<b>LTCW-150</b>		
Chamber Length	m	3.0		
Maximum Water Temperature Set Point	°C	85 (1 <sup>st</sup> and 2 <sup>nd</sup> chambers only)		
<b>Filament Roller Haul-Off Unit</b>		<b>LCAT-130</b>		
Maximum Operating Speed	m/min	130		
<b>Filament Horizontal Accumulator</b>		<b>LHFA-200</b>		
Maximum Accumulated Filament Length	m	200		
<b>Filament Traverse Winder</b>		<b>LWU-130</b>		
Maximum Operating Speed	m/min	130		
Spool Type	-	RS200	RS300 (optional)	RS350 (optional)
Spool Diameter	mm	200	300	350
Spool Width	mm	45	65	90
<b>General Line Specifications</b>				
Mono Filament Output for Ø 1.75 mm at 130 m/min	kg/hr	ABS: 23.0		PLA: 19.0
Mono Filament Output for Ø 2.85 mm at 60 m/min	kg/hr	ABS: 28.0		PLA: 23.0
Line Dimensions (L x W x H)	m	10.50 x 2.10 x 2.20		

## Materials

- Engineering Thermoplastics: PA, TPE, PETG, TPU
- Commodity Thermoplastics: PP
- Biodegradable Thermoplastics: PLA

## Applications

- Educational and Technical Training
- Customization and Short-Run Production
- Product Development and Process Optimization
- Research and Development in Advanced Filament
- Quality Control Testing and Fused Deposition Modeling

**NOTE** Customization available upon request. Filament output is influenced by several factors, such as material viscosity, die diameter, and line speed.

## Benchtop Laboratory Scientific

Streamlined for use in limited spaces and easy to operate, even for users with no prior experience in filament production. This affordable in-house solution consumes minimal material, which is crucial when working with expensive materials.



### Features

- Compatible with 20 mm or 25 mm Single-Screw Extruders based on output requirements
- Precise filament diameter control for various polymer viscosities
- Space-saving design with combined Water Bath and Winder stations
- Two-chamber Water Bath for thermal shock prevention
- Sizing tool for alignment and water leak prevention
- Air wiper for removing residual water
- Mechanical traverse guide ensures even filament distribution
- Supports uninterrupted production for consistent quality

### Options

- Swingable Die Support Attachment
- Dual-Axis Laser Diameter Gauge
- Closed-Loop Feedback Haul-Off System

### Materials

- Standard Thermoplastics: PP, PE
- Engineering Thermoplastics: ABS, PA, TPE, PETG
- Biodegradable Thermoplastics: PLA
- Composites with a wide range of Additives such as Colorants and Fillers

### Applications

- Academic and Technical Training
- Custom Material Characterization Research Projects
- Product Development Testing for Commercialization

### Technical Specifications

Benchtop Laboratory Scientific 3D Filament Extrusion Line			
Single-Screw Extruders		LE20-30/C	LE25-30/C
Maximum Screw Speed	RPM	up to 150	up to 300
Maximum Barrel Temperature	°C	300 (optional 400)	
3D Filament Die Diameter	mm	1.75 and 2.85	
Filament Cooling Compact Water Bath		LCFW-120/L1.2	
Water Bath Length	m	1.2	
Maximum Water Temperature Set Point	°C	85 (1 <sup>st</sup> chamber only)	
Filament Compact Traverse Winder		LWU-15	
Maximum Operating Speed	m/min	15	
Spool Type	-	RS200	
Spool Diameter	mm	200	
Spool Width	mm	45	65
General Line Specifications			
Mono Filament Output for Ø 1.75 mm at 15 m/min	kg/hr	ABS: 2.2	PLA: 2.6
Mono Filament Output for Ø 2.85 mm at 10 m/min	kg/hr	ABS: 3.9	PLA: 4.7
Line Dimensions with LE25 (L x W x H)	m	5.60 x 0.84 x 1.63	

**NOTE** Customization available upon request. Filament output is influenced by several factors, such as material viscosity, die diameter, and line speed.

# Benchtop Laboratory Scientific Pharmaceutical

Designed for cost-effective processing of medical-grade resin materials into high-quality 3D filaments. The system accommodates a wide range of filament diameters, both standard industry sizes and custom specifications, ensuring versatility and precision in manufacturing.

## Features

- Produces sterile filaments, free from contaminants to prevent infections
- Complies with GMP and other international safety standards
- Equipped with vacuum sizing tank for stabilizing diameter of extruded profiles

## Options

- Swingable Die Support Attachment
- Dual-Axis Laser Diameter Gauge
- Closed-Loop Feedback Haul-Off System



## Materials

- Polylactic Acid (PLA)
- Medical-Grade Polyamide (Nylon)
- Thermoplastic Polyurethane (TPU)
- Medical-Grade Polycarbonate (PC)
- Polyethylene Terephthalate Glycol (PETG)

## Applications

- Rapid prototyping of implants specific for patient anatomy
- Building miniature organ models for drug testing and disease modeling
- Customized surgical tools and medical devices for specific procedures
- Medical research for development of new drug delivery systems

## Technical Specifications

### Benchtop Laboratory Scientific Pharmaceutical 3D Filament Extrusion Line

Single-Screw Extruders		LTEP12-40	
Maximum Screw Speed	RPM	up to 800	
Maximum Barrel Temperature	°C	150	
3D Filament Die Diameter	mm	1.75 and 2.85	
Filament Cooling Compact Water Bath		LFVW-100/L1.2	
Water Bath Length	m	1.2	
Maximum Water Temperature Set Point	°C	85	
Filament Compact Traverse Winder		LWU-15	
Maximum Operating Speed	m/min	15	
Spool Type	-	RS200	
Spool Diameter	mm	200	
Spool Width	mm	45	65
General Line Specifications			
Mono Filament Output for Ø 1.75 mm at 15 m/min	kg/hr	ABS: 2.2	ABS: 2.6
Mono Filament Output for Ø 2.85 mm at 10 m/min	kg/hr	ABS: 3.9	ABS: 4.7
Line Dimensions with LTEP12 (L x W x H)	m	2.50 x 0.84 x 1.63	

**NOTE** Customization available upon request. Filament output is influenced by several factors, such as material viscosity, die diameter, and line speed.

# Pipe, Tube, Hose and Profile Ex

## Pipe Line

Labtech offers customizable Pipe Extrusion Lines according to customer requirements. The core of the process involves melting plastic resin and shaping it into a tubular form with a pipe die, cooling it through a vacuum cooling and calibration bath, and finally cutting it to desired lengths using a haul-off system and pipe cutter.

### Features

- Compatible with 30 mm to 45 mm Single-Screw Extruders based on output requirements
- Precise diameter, wall thickness control and smooth exterior surface
- Modular downstream units and customizable pipe sizes
- Large vacuum tank for extensive pipe cooling
- Vacuum chamber with sizing tools for accurate pipe sizing
- Haul-off with wear-resistant rubber belts
- Caterpillar belt with pneumatic cylinders for adjustable nip pressure
- Automatic pipe saw with return-to-start after cutting



### Materials

- PVC
- ABS
- Polyamide (PA)
- Polyolefin (HDPE, LDPE, and PP)

### Applications

- Chemical pipes for handling corrosive chemicals
- Construction pipes for water supply and distribution
- Irrigation and drainage agriculture systems

Technical Specifications			
Pipe Extrusion Line			
Pipe Die Outer Diameter	mm	20 to 32	
<b>Vacuum Calibration and Cooling Pipe Water Bath</b>		<b>LFVW-100/L5.8</b>	
Vacuum Tank Length	m	5.8	
<b>Pipe Caterpillar Haul-Off Unit</b>		<b>LCAT</b>	
Maximum Operating Speed	m/min	20	
Effective Traction Length	mm	1000	
<b>Pipe Saw Cutting Unit</b>		<b>LPSC for rigid PVC pipes</b>	<b>LPSC for soft pipes</b>
Maximum Cutting Diameter	m/min	32	32
Cutting Method	-	Swarfless Rotary Cutting	Fly-Knife Cutting

# trusion Lines

## Medical Tube Line



Our Medical Tube Extrusion Line has been developed in partnership with leading European experts and trusted by multiple European companies for its reliability and high performance.



### Features

- Sterile cutting mechanism to prevent contamination
- Accurate counting and stacking system for efficient batch processing
- Specially designed for medical tubing, minimizing shear stress for consistent quality
- Water Bath with vacuum calibration and precise cooling temperature control

### Materials

- Polyvinyl Chloride (PVC)
- Polyolefin (HDPE, LDPE, and PP)
- Thermoplastic Polyurethane (TPU)

### Applications

- Medical Tubes employed in medical equipment, such as IV tubes, catheters, and respiratory devices

### Technical Specifications

Medical Tube Extrusion Line			
Tube Die Outer Diameter	mm	1 to 12	
<b>Vacuum Calibration and Cooling Tube Water Bath</b>			<b>LMCV06-25</b>
Water Bath Length	m	4	
Maximum Water Temperature Set Point	°C	85	
<b>Caterpillar Haul-Off and Cutting Unit</b>			<b>LMHC03-035-R</b>
Effective Traction Length	mm	300	
Maximum Pulling Speed	m/min	40 to 60	
Cutting Length Range	mm	100 to 2000	
<b>Outfeed and Stacking Conveyors</b>		<b>LMOS-2500</b>	<b>LMOS-4000</b>
Air Blow Length	m	2.5	4
Speed Range	m/min	5 to 60	

## Hose and Tube Lines

Labtech's Hose and Tube Extrusion Lines are designed to produce small-diameter tubes and hoses with adjustable wall thicknesses ranging from 2 to 3.5 mm. Our systems are suitable for both standard and medical applications, including extruders, extrusion dies, vacuum calibration and cooling systems, haul-off and cutting units, as well as take-off and winding.



LCAT  
**Tube Extrusion Line with Stacking Conveyor**

### Features

- Capable of handling various profiles, including small-diameter tubing, pipes, and hoses
- Ensures precise sizing and shape control
- Customizable for specific production requirements and materials
- Stainless steel vacuum calibration and cooling water bath
- Vacuum chamber with Venturi strand suction units
- Heavy-duty hinged Plexiglas lid with quick vacuum release valve
- Large water tank with vacuum pump for water circulation
- Temperature-controlled heater maintains water temperature
- Customizable downstream units

### Options

- Hose Traverse Winder
- Large Hose Traverse Winder
- Dual-Axis Laser Diameter Gauge
- Automatic Pipe Stacking Conveyor
- Computerized Laser Calibration Unit
- High-Speed Caterpillar Haul-Off Unit
- Closed-Loop Feedback Haul-Off System
- Three-Axial Alignment Handwheel for Water Bath



LCAT-25  
**Tube Extrusion Line with Winder**



LWU  
**Hose Extrusion Line**

### Materials

- Polyvinyl Chloride (PVC)
- Polyolefin (HDPE, LDPE, and PP)
- Thermoplastic Polyurethane (TPU)

### Applications

- Flexible conduits used for conveying fluids, gases, and materials in various applications
- Small-scale irrigation systems and garden ornaments



LE30-30/C

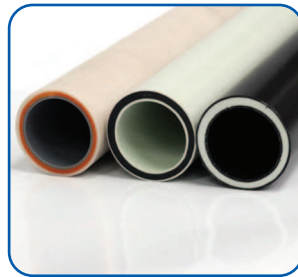

Multilayer Pipes

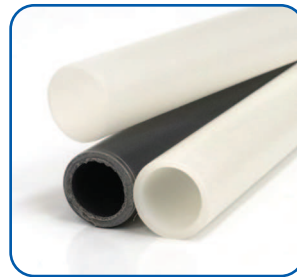

Flexible Hoses



Tube



LE25-30/C



LE25-30/C

### Technical Specifications

#### Hose and Tube Extrusion Lines

Tube Die Outer Diameter	mm	1 to 12	
<b>Vacuum Calibration and Cooling Tube Water Bath</b>		<b>LFVW</b>	
Water Bath Length	m	2.5 to 4	
Maximum Water Temperature Set Point	°C	85	
<b>Caterpillar Haul-Off Unit</b>		<b>LCAT</b>	
Belt Width	mm	82	
Effective Traction Length	mm	220	
Maximum Operating Speed	m/min	40 to 60	
<b>Traverse Winder (Soft Tubes)</b>		<b>LWU-25</b>	
Maximum Operating Speed	m/min	15	
Winding Diameter	mm	350	
Winding Width	mm	90	
<b>Caterpillar Haul-Off and Cutting Unit (Soft/Rigid Hose and Tubes)</b>		<b>LMHC 03-035-R</b>	
Belt Width	mm	82	
Effective Traction Length	mm	220	
Maximum Pulling Speed	m/min	40 to 60	
Maximum Cutting Speed	RPM	2000	
Cutting Length Range	mm	100 to 2000	
<b>Outfeed and Stacking Conveyors (Soft/Rigid Hose and Tubes)</b>		<b>LMOS 2500</b>	<b>LMOS 4000</b>
Air Blow Length	m	2.5	4
Speed Range	m/min	5 to 60	
Adjustable Height	mm	960 to 1060	

**NOTE** Customization is available upon request

## Extrusion Dies

Our extrusion dies efficiently handle heat-sensitive materials with streamlined flow paths to reduce temperature degradation and precision-machined cavities. Advanced simulation software ensures faster setup and better product quality.

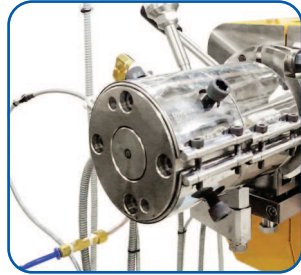
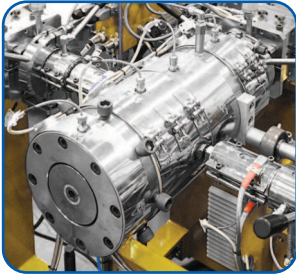

These adaptable dies allow for easy switches of the die mandrel and outer ring. Calibration disks in the vacuum tank must be adjusted accordingly. Though they share a common function, differences in internal geometry and features help achieve the desired shape and properties.

### Pipe Die

#### Features

- Produces round, hollow shapes with consistent 2 to 3 mm wall thickness
- Outer diameters ranging from 20 to 32 mm
- Compressed air supports tube wall shape inside the die during extrusion

### Tube Die

#### Features

- Produces round, hollow shapes with uniform wall thicknesses of 0.05 to 2 mm
- Outer diameters ranging from 1 to 12 mm
- Mandrel adjustment with centering bolts for die lips alignment

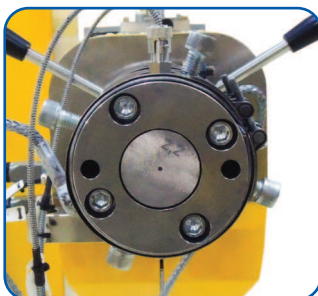
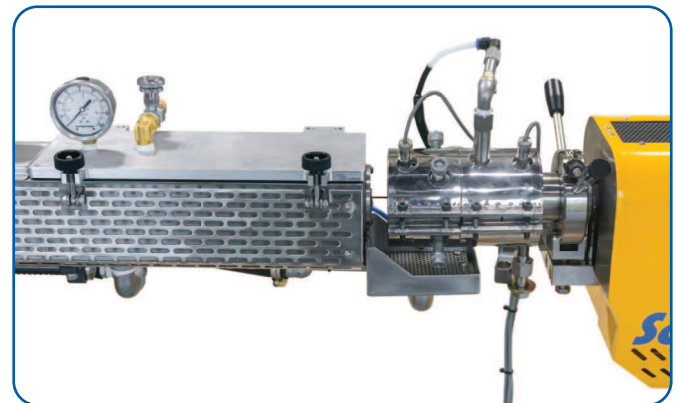

### Hose Die

#### Features

- Ideal for producing reinforced and flexible hose products
- Forms flexible, tubular shapes with variable wall thicknesses
- Features enhancements like corrugations or ribs for added strength

### Profile Die

#### Features

- Accommodates rigid, soft, or co-extruded polymers
- Designed in partnership with leading European toolmakers
- Profile heads equipped with custom-designed tooling for non-circular shapes
- Suitable for producing structural or functional components in various industries

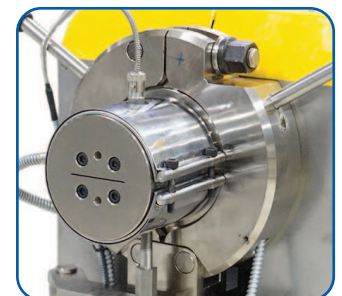

## Haul-Off Units

High-performance Haul-Off units for extrusion lines are designed to efficiently pull extruded products from the die and guide them through the cooling section at a steady, controlled speed.

With precise speed control, they ensure consistent product quality and dimensional accuracy.



for Pipe Line



for Medical Tube Line



for Tube Line

## Wind-Up Units

Reliable and efficient Wind-Up units for tube, hose, and profile extrusion lines accommodating various product shapes and sizes, from small-diameter tubing to larger flexible hoses.

Their synchronizable design integrates seamlessly with other line units, neatly coil the finished product, ensuring organized handling and storage.



for Tube Extrusion

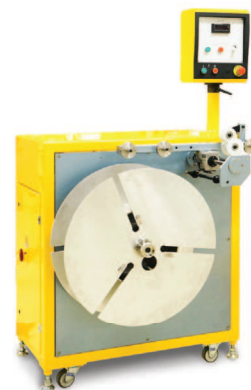

for Hose Extrusion

# Bottle Blow Moulding Machines

Labtech's Bottle Blow Moulding Extrusion Line is a lab-scale machine for producing durable plastic bottles offered in two bottle sizes (125 and 250 cc) with various customization options, including shapes, wall thicknesses and features like handles and closures. Branding elements, such as logos can also be incorporated into the bottle design.

## ⚙️ Features

- Leak-free bottle inflation within the mould
- Parison Hot Cutter System with heated flat steel strip and pneumatic piston for precise cutting without distortion
- Fully automatic and hydraulic-driven pressure system operation
- Heat exchanger for optimal hydraulic oil temperature
- Blow Moulding Area (Parison Die, Blowing Unit and Mould Carriage) safely housed in an aluminium frame with acrylic panels

## 📝 Options

- Touchscreen Control Panel
- Different Mould Designs and Logo Engraving



125 cc bottles



Type LBM-125/LBM-250

## 🏠 Single-Layer

Single-Layer Bottle Blow Moulding Extrusion Lines are used to produce bottles made from a single type of plastic resin. This process involves heating the resin, extruding it into a parison, and then blowing the parison into a mould to form the desired bottle shape.

## ⚙️ Features

- Produces single-layer bottles with excellent mechanical properties
- Conical or tulip mandrel controls the parison thickness and prevents sagging
- Die parison adjustment allows precise die lip centering for uniform parison and consistent bottle quality
- Spider die head evenly distributes melt for consistent parison formation
- Flexible Extruder Options:
  - 20 mm Extruders
  - 30 mm Extruders

## Materials

- Polypropylene (PP)
- Polyvinyl Chloride (PVC)
- Low-Density Polyethylene (LDPE)
- Polyethylene Terephthalate Glycol (PETG)
- High-Density Polyethylene (HDPE)

## Applications

- Bottle Color Evaluation and Prototyping
- Product Development for Bottle Packaging
- Small-Scale Plastic Bottle Manufacturers
- Research Institutions, University Laboratories, and Government Agencies for Polymer Research

## Multi-Layer

Multi-Layer Bottle Blow Moulding Co-Extrusion Lines are used to produce bottles with multiple layers of different plastic resins.

This process involves simultaneously extruding multiple resins through a die, forming a layered parison, and then blowing the parison into a mould.

## Features

- Continuous operation with a single parison and blow station
- Production of bottles with 2 to 3 layers for enhanced properties
- Dual co-axial spiral mandrels with conical-shaped end inner mandrel for precise die gap adjustment
- Special co-extrusion die with spider inlets and spiral flow channels for even melt distribution without flow lines
- Flexible Extruder Options:
  - 2-Layer configuration with 25 mm and 20 mm Extruders
  - 3-Layer configuration with 3 units of 20 mm Extruders



Type LBM-125/COEX



Type LBM-250/COEX

### Technical Specifications

Bottle Blow Moulding Machines		LBM-125	LBM-250	LBM-125/COEX	LBM-250/COEX
Bottle Size	cc	125	250	125	250
Bottle Production Capacity	bottles/hour	140			
Hydraulic Motor Power	kW	2.2			
Maximum Hydraulic Pressure	bars	50			
Dimensions (L x W x H)	m	1.64 x 1.20 x 1.80			

# Two-Roll Mills

Labtech Two-Roll Mills offer precision temperature-controlled rollers to apply intense shear forces and heat. This enables precise mixing and dispersion, improving product quality. We customize solutions to optimize unique customer needs for rubber and plastic processing.

## ⚙️ Features

- Advanced 3-zone heating system
- Independent roll speed control to allow friction ratio variation
- Synchronous roll speed control for maintaining constant friction ratio
- Knee-activated emergency stops
- Interlocked safety cage over the rolls

## ✔️ Applications

- Quality control of materials
- Sample preparation and research analysis
- Academic experiments and training programs
- Production of test sheets or samples for compounding customers
- Material testing such as compression, tension, and bending to evaluate material properties.

## 📄 Options

- Roll Temperature Systems
  - └ Water Cooling
  - └ Combined Electric Heating and Water Cooling
- Operational Safety Systems
  - └ Emergency Pneumatic (Benchtop only)/Hydraulic Quick Opening System
  - └ Overheat Protection System
- Process Control
  - └ Infrared Temperature Measuring Device
  - └ Motorized Nip-Gap Control
  - └ Motorized Take-off Roll with Water Cooling
  - └ Horizontally Adjustable Bronze/Teflon Side Guides
  - └ Sub-Cabinet with Casters for Benchtop Models



Computerized Controls



Oil Heating of Rolls  
(190 °C or 250 °C)



Automatic Rollover Device

## Benchtop Laboratory Scientific

Our benchtop model delivers precision and efficiency in a space-saving design, ideal for laboratories and research facilities with limited space requirements.

### Features

- Space-efficient design for small batch size compared to standard floor mills
- Ratchet wrenches with micrometric scales for precise nip-gap adjustment
- Smooth operation across all speed ranges
- Advanced electric heating system for uniform temperature distribution



Type LRM-M-100



Type LRM-M-100

with Optional Subcabinet

### Technical Specifications

Benchtop Laboratory Scientific Two-Roll Mills		LRM-M-100
Roll Diameter	mm	100
Roll Width	mm	210
Working Width	mm	150
Approximate Capacity (with a Compound Density of 1.0)	g	30 to 50
Nip-Gap Distance Adjustment	mm	0.10 to 10.0
Maximum Temperature (Standard Heating)	°C	300
Dimensions (L x W x H)	m	0.90 x 0.45 x 0.82

## Laboratory Scientific

### Standard Mills

Engineered for versatility and precision, this model bridges the gap between research capabilities and production-scale processing.

#### Features

- Centralized handwheel gap adjustment for absolute roll parallelism
- Digital electronic control for accurate readout of gap settings



Type LRM-S-150

### Rubber Mills



Type LRMR-SC-110

with Computerized Control Option

Engineered to handle intensive rubber processing with high-grade tool steel rolls and water cooling. Equipped with an infinite speed individual roll control to maintain friction ratio for diverse rubber processing recipes.

#### Features

- Heavy-duty construction with enhanced roll drive power and superior torque handling
- Water-cooled rolls with spiral channels near roll surface for optimum cooling efficiency

### Technical Specifications

Laboratory Scientific Two-Roll Mills		Standard Mills			Rubber Mills		
		LRM-S-110	LRM-S-150	LRM-S-200	LRMR-S-110	LRMR-S-150	LRMR-S-200
Roll Diameter	mm	110	150	200	110	150	200
Roll Width	mm	280	400	450	280	400	450
Working Width	mm	220	320	370	220	320	370
Approximate Capacity (with a Compound Density of 1.0)	g	100 to 500	200 to 400	500 to 1000	100 to 500	200 to 400	500 to 1000
Nip-Gap Distance Adjustment	mm	0.10 to 5.0			0.20 to 10	0.20 to 20	
Maximum Temperature	°C	Electric Heating 300 (Standard) Oil Heating 190 or 250 (Option)			No Heating (Standard) Electric Heating 300 (Option) Oil Heating 190 or 250 (Option)		
Cooling Method	-	No Cooling (Standard) Water Cooling (Option)			Controlled Water Cooling		
Dimensions (L x W x H)	m	1.84 x 0.88 x 1.67	2.05 x 1.14 x 1.73	2.42 x 1.25 x 1.87	1.84 x 0.88 x 1.67	2.25 x 1.15 x 1.73	2.42 x 1.25 x 1.87

# Press Machines

Presses are used in the manufacturing of polymer sheets for optical and physical testing of molded forms. Built in full conformance to international safety standards, Labtech offers both Electric and Hydraulic Press machines suitable for composites, components or for embossing depending on requirements.

## ⚙️ Features

- Dual precision-ground, hard-chromed platens
- Electric heating on the upper platens and zigzag water-cooling channels on the lower platens
- Heating platen features heater cartridges for even heat distribution and high-density ceramic insulation to minimize heat loss
- Plexiglas window for visibility

## ✔️ Applications

- Quality control of materials
- Sample preparation and research analysis
- Academic experiments and training programs
- Production of test sheets or samples for compounding customers
- Material testing such as compression, tension, and bending tests to evaluate material properties.

## 📝 Options

- Sub-Cabinet with Casters for Benchtop Versions
- High-Temperature Versions at 400 °C or 450 °C
- Water Chiller Unit
- Press Platen Configurations
  - ↳ Single Platen Set (Heating & Cooling)
  - ↳ Automatic Insert Platens (Cooling)
  - ↳ Double Platen Set (Heating & Cooling)
  - ↳ Double Platen Set (Both Heating Only)
  - ↳ Double Platen Set (Both Heating & Cooling)
  - ↳ Larger Platen Sizes of 300 or 400 mm
- Control Options
  - ↳ Fully Computerized Controls
  - ↳ LCD Colored Touch Screen Control
  - ↳ Dual or Triple Set of Pressure Regulators
  - ↳ Digital Pressure Readout in kN
  - ↳ Digital Timers



Electric Press Type LPE-S-20



Hydraulic Press Type LP-S-20



Optional Computerized Control



Press Samples

**Laboratory Scientific**

**Benchtop Hydraulic Press**

**Features**

- Adjustable stroke for platen opening
- Compact press, ideal for limited workspace
- Single-stage hydraulic gear pump system with a single-acting piston



**Type LP20-B**

with Optional Subcabinet

**Standard Hydraulic Press**

**Features**

- Quiet two-stage pump system
- High closing speed at low pressure and low pressing speed at high pressure
- Double-acting press piston opens if pressing compound gets stuck between platens
- Pressure-regulating knob adjusts pressure from 10% to 100% of the maximum



**Type LP-S-20**

with Optional Automatic Insert Cooling



**Pressing Mold**

Press Machines		Benchtop
		LP20-B
Press Capacity	MT	20
Maximum Platen Pressure	kg/cm <sup>2</sup>	50
Platen Sizes	mm	200 x 200
Maximum Daylight Opening	mm	100
Maximum Platen Temperature	°C	300
Approximate Heating Time to 150 °C	min	
Dimensions (L x W x H)	m	0.73 x 0.64 x 1.09

**NOTE** Other sizes available upon request

## ASTM Hydraulic Press

### Features

- ASTM D4703 compliant compression molding press
- Programmable cooling rates (2-30 °C/min)
- Single-platen design with advanced dual-channel cooling and heating
- LCD touchscreen control and pressure-regulating knobs
- Available in fully computerized option with multi-pressure control and daylight adjustments

## Electric Press

### Features

- World's first fully electric version featuring electrically driven insert platens
- Heavy-duty and high-precision ball screw driven by AC gear motor for upstroke pressure
- Insert cooling system with insulated ceramic platens for cooling
- Fully automatic and computerized with large touchscreen control



**LP-S-50/COMP.ASTM**  
with Optional Chiller



**Type LPE-S-20**

## Technical Specifications

### Laboratory Scientific

Hydraulic Press	Standard Hydraulic Press				ASTM Hydraulic Press		Electric Press
LP30-B	LP-S-20	LP-S-30	LP-S-50	LP-S-80	LP-S-50/ASTM	LP-S-80/ASTM	LPE-S-20
30	20	30	50	80	50	80	20
33	50	33	55	50	55	50	50
300 x 300	200 x 200	300 x 300	300 x 300	400 x 400	300 x 300	400 x 400	200 x 200
	150						
(option 450)	300 (option 400 or 450)						300 (option 450)
	10						
0.85 x 0.75 x 1.15	1.13 x 0.83 x 1.60		1.30 x 1.00 x 1.70				1.13 x 0.83 x 1.60

# Filter Testers

Designed to evaluate polymer quality by detecting defects in the melt flow. It measures pressure buildup across a filter screen and evaluates via Filter Pressure Value (FPV).

The Mini Compact Filter Tester integrates control of both filter test head and extruder in a single panel, while our Standard Filter Testers offer detachable extruders for versatile applications beyond filtration.

## ⚙️ Features

- Streamlined filter test head with no dead corners for easy and fast cleaning
- Quick-lock filter head for fast and easy screen changing
- Automatic calculation of FPV
- Built-in data management capabilities for easier tracking of test results
- Generates stacked graphs to compare multiple filter test results simultaneously



Type LFT34-GP / LFT44-GP / LFT57-GP

## 📄 Options

- Adaptor for compatibility of LFT44 and LFT57 with DIN Norm
- Strand Die supplied on a practical hinged mount

## 🏭 Laboratory Scientific

### LCFT34-GP



Type LCFT34-GP

### LFT34-GP

Equipped with 34 mm filter disks according to DIN NORM EN ISO 23900-5.

### LFT44-GP

Features a 30% larger filter area with 44 mm disks for higher flow rates.

### LFT57-GP

Designed for assessing impurities in PP virgin resins per ASTM D3218. It also has 50% larger filter area, which increases the precisions of the tests.

## 🧪 Materials

- Virgin Polymers (PE, PP, PET, etc.)
- Compounds and Masterbatches
- Recycled Materials (rPET, rPE, rPP, rPS)

## ✔️ Applications

- Product development
- Quality monitoring and control
- Regulatory compliance with industry standards of masterbatches, compounds or polymers

## Filter Packs

### Labtech Filter Packs

Built up of 3 layers of stainless-steel mesh, with the first layer comprising a very fine special woven mesh with extremely small openings. Five sizes are available, covering all required applications. Labtech provides filter packs in two convenient diameters: 34 mm and 44 mm.

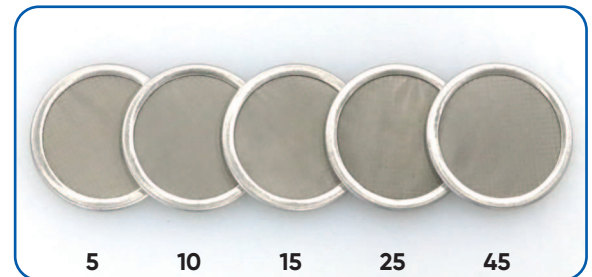

Labtech Filter Packs (Microns)

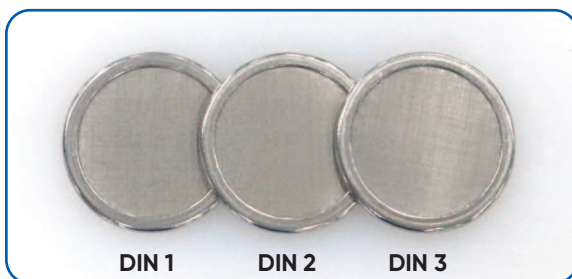

DIN NORM EN ISO 23900-5

### DIN NORM EN ISO 23900-5

Labtech supplies 34 mm filter disks that meet the DIN NORM EN ISO 23900-5 available in DIN 1, DIN 2, and DIN 3 specifications, providing options to suit different filtration needs.

### ASTM D3218

The ASTM D3218 Filter Pack consists of a combination of five filter discs with varying microns, designed for precise filtration.

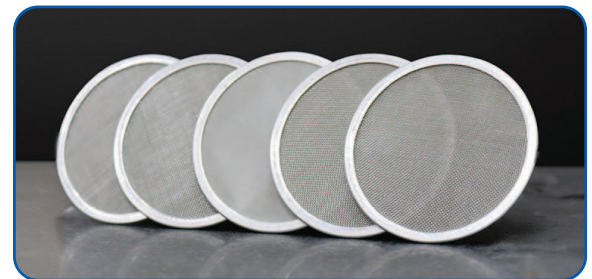

57 mm: 44-44-13-44-44 (Microns)

### Technical Specifications

Filter Testers		Laboratory Scientific			
		LCFT34-GP	LFT34-GP	LFT44-GP	LFT57-GP
Gear Pump Motor Power	kW	0.75			
Gear Pump Inlet Pressure	bar	0 to 150			
Gear Pump Outlet Pressure	bar	0 to 300			
Recommended Test Quantity	kg	0.2 to 0.5		0.5 to 1.0	
Single-Screw Extruder Size	mm	20		25	
Screw L/D Ratio	-	30 : 1			
Motor Power	kW	1.5		4	
Maximum Screw Speed	RPM	up to 150		up to 200	
Maximum Output with LDPE	kg/hr	6		15	
Dimensions (L x W x H)	m	1.53 x 1.13 x 1.85	2.82 x 0.63 x 1.83	3.38 x 0.81 x 1.83	

# Benchtop Laboratory Scientific

The Benchtop Laboratory Scientific Line is a compact version of the Laboratory Scientific Line, designed to fit on a laboratory table for research, testing, and educational use. Its space-saving design makes it ideal for routine R&D work and for laboratories that need reliable results without large-scale equipment.

## ☼ Compounding Line

### ▮▮ Twin-Screw Extruders



### ▮▮ High Speed Mixer

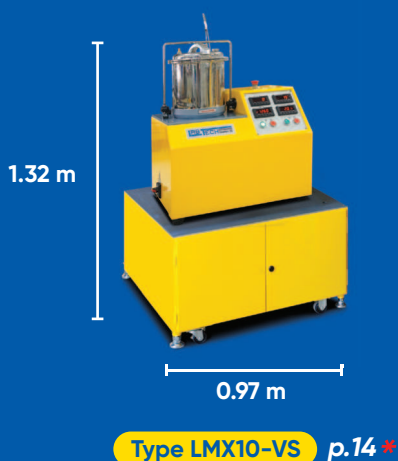

### ▮▮ Downstream Units: Water Bath and Pelletizer



# Lines

## 3D Filament Lines

### Pharmaceutical Line



Type LTEP12-40 & COMBI LFW-100/L1.2 + LWU p.50 \*

### Thermoplastic Line



Type LE20-30/C & COMBI LCFW-120/L1.2 + LWU p.49 \*

**\*Note:** Please refer to the specified pages for more information about each machine.

## Two-Roll Mill



Type LRM-M-100 p.60 \*

## Hydraulic Press



Type LP20-B p.63 \*

## Filter Tester



Type LCFT34-GP p.65 \*

# Mini Scientific Lines

Labtech's Mini Scientific Line represents a comprehensive series of machines that simulate various plastic processing techniques. The product range covers all key areas of polymer processing, including film or sheet production, compounding, pelletizing, filament and yarn extrusion. Integrated components ensure quick setup, smooth operation, and easy mobility.

## Blown Film Lines

### Single-Layer

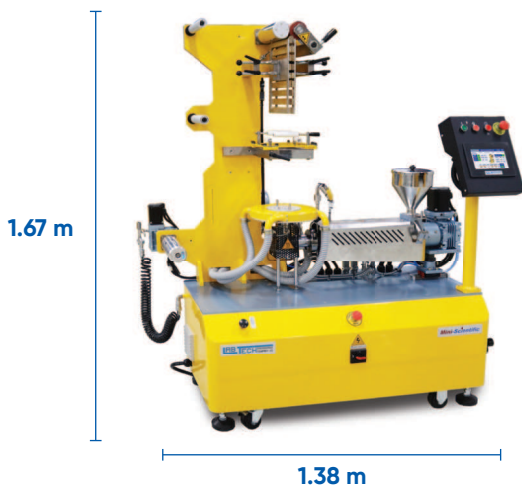

Type LMF-200 p.18 \*

### Multi-Layer

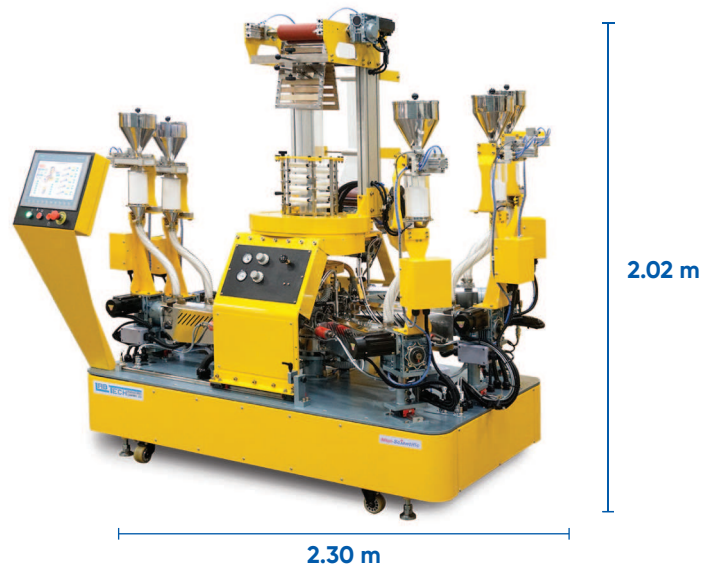

Type LMF-200/COEX p.22 \*

## Cast Film and Sheet Lines

### Single-Layer

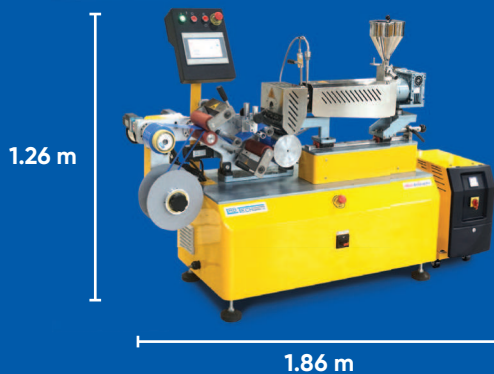

Type LMCR-150 p.34 \*

### Multi-Layer

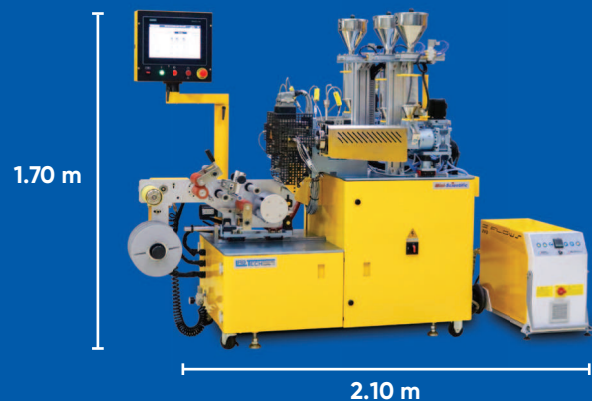

Type LMCR-150/COEX p.38 \*

# Combi Blown Film and Cast Film/Sheet Line

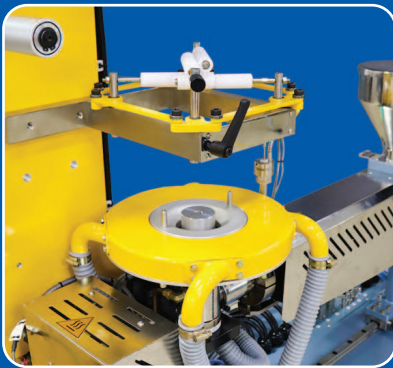

**Spiral Mandrel  
Annular Die Assembly**

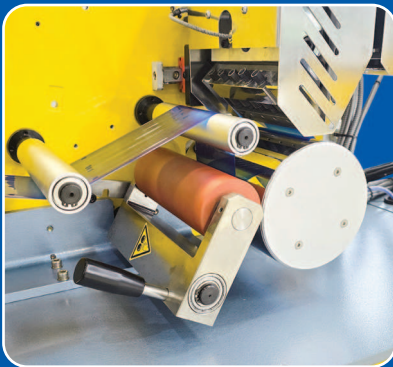

**Chill Roll**



**Type LMF-200 + LMCR-150**

## Features

- Save space and cost by combining two machines into one
- Test materials in both methods to optimize production
- Quick changeovers between blown film and cast film/sheet production
- Minimizes material waste and simplifies operation with a single extruder

## Technical Specifications

### Mini Scientific Combi Blown Film + Cast Film and Sheet Extrusion Line

Single-Screw Extruder		LME16-30/C	
Estimated Maximum Output (LDPE)	kg/hr	2	
Maximum Processing Temperature	°C	300	
Blown Film Attachment		LMF-200	
Die Lip Gap	mm	0.8	
Maximum Film Lay Flat Width	mm	180	
Approximate Film Thickness Range (depending on resin type)	µm	20 to 80	
Cast Film / Sheet Attachment		LMCR-150	
Die Lip Gap Range	mm	0.3 to 2	
Die Width	mm	125	
Approximate Film/Sheet Thickness Range (depending on resin type)	µm	20 to 1000	
General Line Specifications			
Maximum Line Speed	m/min	12	
Dimensions (L x W x H)	m	2.14 x 0.89 x 1.75	

# Combi Pelletizing and 3D Filament Line

## Features

- Easy switch between pelletizing and filament production
- Dual cooling options:
  - Water Bath for non-water sensitive materials
  - Air Conveyor for water sensitive materials
- Uniform pellet cutting via a high-speed pelletizer
- Filament output collected by a traverse spool winder

## Materials

### Filament Extrusion Line

- Standard Thermoplastics: PP, PE
- Engineering Thermoplastics: ABS
- Biodegradable Thermoplastics: PLA

### Pelletizing Line

- Standard Thermoplastics: PP, PE
- Engineering Thermoplastics: ABS, PETG, TPE
- Biodegradable Thermoplastics: PLA
- Composites with a wide range of Additives such as Colorants and Fillers

## Technical Specifications

Mini Scientific Combi Pelletizing and 3D Filament Extrusion Line		
Single-Screw Extruder		LME16-30-MCP-3D
Estimated Maximum Output (LDPE)	kg/hr	2
Available L/D Ratio	-	30 : 1
Maximum Processing Temperature	°C	300
3D Filament Extrusion Line		
Die Hole	mm	Ø 1.75 and 2.85
Bath Tank Length	mm	960
Maximum Water Temperature Set Point	°C	85
Traverse Drive Type	-	Mechanical Transverse Drive
Maximum Winder Speed	m/min	15
Pelletizing Line		
Die Hole	mm	Ø 1.75 and 2.85
Bath Tank Length	mm	960
Air Conveyor Legth	mm	960
Pellet Length	mm	3
Max In-Feed Speed	m/min	36
Number of Rotary Knives	-	6
Dimensions (L x W x H)	m	9.40 x 2.12 x 1.64



Transverse Spool Winder Unit



Pelletizing Unit



Type LME16-30-MCP-3D

## Melt Spinning Line



Type LSP-1000



Spinneret Die

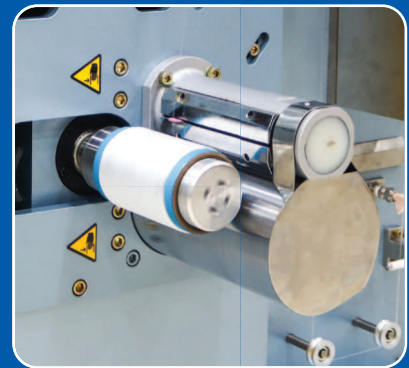

Wind-Up Bobbin with Grooved Drum

### Features

- Possibly the smallest fully functional spinning line in the world
- Produces fine, round-shaped POY and FDY yarns with a smooth surface, high strength and flexibility
- Precise speed and temperature control allow for optimal draw ratios and filament orientation
- User-friendly interface with touchscreen controls

### Materials

- Polyester (PET)
- Polyolefin (PE, PP)
- Biodegradable Polymers (PLA)

### Technical Specifications

Mini Scientific Melt Spinning Line		LSP-1000
Estimated Maximum Output (Single-Screw Extruder)	kg/hr	2
Denier Range	D	50 to 150 D
Spinneret Hole Diameter	mm	0.3
Number of Spinneret Holes	-	8-24
Maximum Godet Temperature	°C	200
Maximum Godet Speed	m/min	1000
Maximum Line Speed	m/min	1000
Dimensions (L x W x H)	m	1.35 x 1.14 x 2.16

# Ultramicro Scientific Lines

Labtech's Ultramicro Scientific Line is a series of tabletop and portable machines, engineered for industrial-grade versatility in a minimal footprint. These scaled-down versions of our larger systems enable precision polymer processing, including ultra-thin films, sheets, compounding, and pelletizing.

## ✔ Applications

- Material Testing and Analysis
- Academic Learning and Quality Control
- Small-Scale Production of Specialized Materials

## 🔧 Blown Film Lines

### Single-Layer

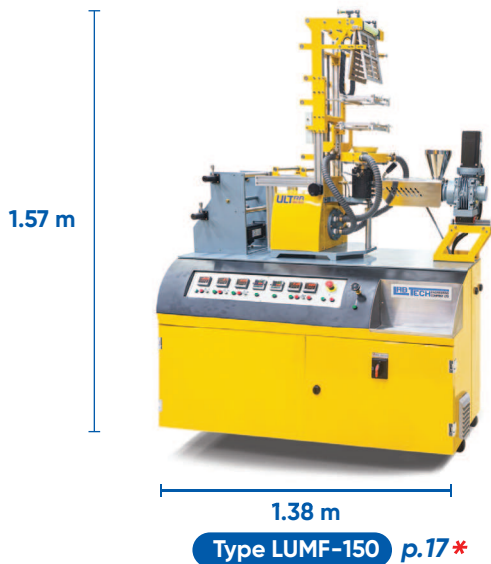

### Multi-Layer



## 🔧 Cast Film and Sheet Lines

### Single-Layer



### Multi-Layer



## Combi Blown Film and Cast Film/Sheet Line

### Features

- Allows easy switching between cast and blown film attachments
- Convenient operation with centralized control at the base



Type LUMCR-50 + LUMF-150

### Technical Specifications

#### Ultramicro Scientific Combi Blown Film + Cast Film and Sheet Extrusion Line

Single-Screw Extruder		LUME8-30/C
Estimated Maximum Output (LDPE)	kg/hr	0.8
Maximum Processing Temperature	°C	300
Blown Film Attachment		LUMF-150
Die Lip Gap	mm	0.8
Maximum Film Lay Flat Width	mm	100
Approximate Film Thickness Range <small>(depending on resin type)</small>	µm	20 to 80
Cast Film / Sheet Attachment		LUMCR-50
Die Lip Gap Range	mm	0.1 to 0.3
Maximum Die Width	mm	Standard : 50
Approximate Film/Sheet Thickness Range <small>(depending on resin type)</small>	µm	20 to 300
General Line Specifications		
Maximum Line Speed	m/min	5
Dimensions (L x W x H)	m	1.31 x 1.26 x 1.60

## Compounding Line

### Features

- Dual-Option Process Visualization of Barrel Cover
  - Crystal-clear view of polymer flow behavior through a PC cover
  - Steel cover for high-temperature processes
- Transparent water bath and side cutter allowing visual demonstration of the operation
- Fully computerized control system



Type LUME8-30/C

### Technical Specifications

Ultramicro Scientific Compounding Line		LUME8-30/C
Conical Screw Diameter	mm	8
Maximum Screw Speed	RPM	up to 300
Maximum Barrel Temperature	°C	PC: 130
		Steel: 300
Water Bath Tank Capacity	L	4.5
Maximum Cutting Speed	m/min	1.3
Pellet Length	mm	3.0
Dimensions (L x W x H)	m	1.24 x 0.60 x 1.19

# Mark II Extrusion Lines

This strategic advancement fills crucial gaps in our standard extrusion lineup, instantly recognizable by its striking blue & yellow design.

The new line maintains the same consistency as our original machines at a more accessible price point, with faster delivery to accelerate projects without compromising professional standards.

## Twin-Screw Compounding Lines Mark II

The Twin-Screw Extruders Mark II deliver precise, efficient polymer processing in a compact, modular design with closed barrel.

Paired with stainless-steel Water Baths Mark II and standard Pelletizers color-matched to Mark II, the system ensures consistent strand cooling, drying, and uniform cutting of soft and hard materials.

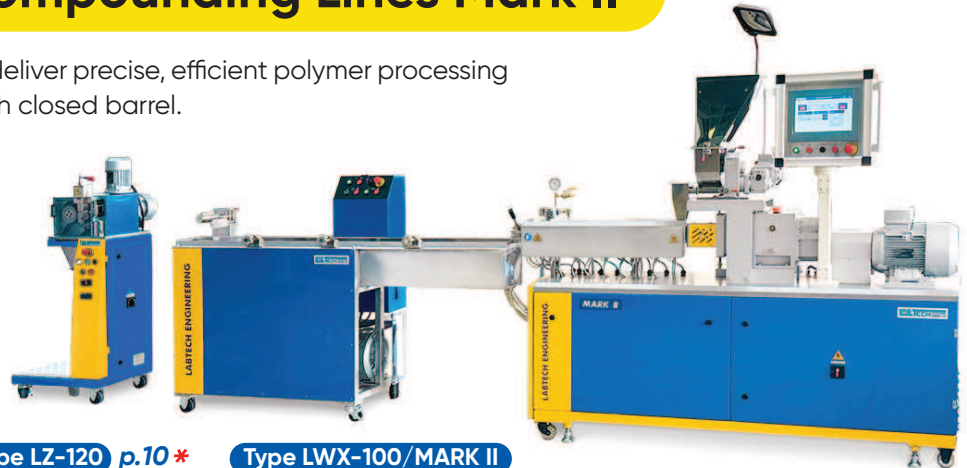

Type LZ-120 p.10 \*

Type LWX-100/MARK II

Type LTCX22/MARK II

### Technical Specifications

Twin-Screw Extruders Mark II		LTCX22/MARK II	LTCX30/MARK II
Screw Diameter	mm	22	30
Available L/D Ratio	-	40 to 48	
Barrel Type	-	Closed Barrel	
Maximum Screw Speed	RPM	up to 800	up to 1000
Maximum Barrel Temp	°C	400	

### Technical Specifications

Water Baths Mark II		LWX-100/MARK II	LWX-150/MARK II
Water Tank Length	m	1.5	2.4
Water Pump Motor Power	kW	0.37	

## Single-Screw Extruders Mark II

The Single-Screw Extruders Mark II offer high-performance, compact solutions for R&D and small-scale production. With efficient mixing, precise temperature control, and touchscreen interface, they process a wide range of polymers, seamlessly integrating with Labtech's Blown and Cast Film Mark II Lines.



Type LEX20-30/MARK II

Type LEX25-30/MARK II

### Technical Specifications

Single-Screw Extruders Mark II		LEX20/MARK II	LEX25/MARK II
Screw Diameter	mm	20	25
Available L/D Ratio	-	30:1	
Maximum Screw Speed	RPM	up to 150	up to 300
Maximum Barrel Temperature	°C	300	
Estimated Max Output	kg/hr	6 (LDPE)	15 (LDPE)

**NOTE** Extruder output varies based on material and downstream equipment.

## Blown Film Extrusion Lines Mark II



The Blown Film Lines Mark II offers efficient film production in a compact, cost-effective design with a lightweight aluminum center column. Compatible with Single-Screw and Recycling Extruders Mark II, it processes virgin and recycled materials.

### Technical Specifications

Blown Film Lines Mark II		LFX-250/MARK II	LFX-400/MARK II
Tower Nip Roll Width	mm	250	400
Maximum Film Lay Flat Width	mm	180	320
Maximum Line Speed	m/min	25	35
Die Lip Diameter	mm	28	45
Die Lip Gap	mm	0.8	

Type LFX-250/MARK II

Type LREX16-25/MARK II p.7\*

## Cast Film Extrusion Line Mark II

The Cast Film Line Mark II delivers high-quality film in a compact, affordable setup for R&D and small-scale production. It features an aluminum frame, adjustable die, two rolls with optional water tempering, and factory-configurable horizontal or vertical roll stack orientation.



Type LCRX-300/MARK II

Type LEX25-30/MARK II p.75\*

### Technical Specifications

Cast Film Line Mark II		LCRX-300/MARK II
Roll Diameter (2 Rolls)	mm	145
Roll Width	mm	350
Maximum Die Width	mm	200, 250, 300
Maximum Roll Temperature (Optional Water Tempering Unit)	°C	120
Die Lip Opening (Adjustment Range)	mm	0.3 – 2.0
Maximum Line Speed	m/min	15