

# Dry Compressing Vacuum Pumps

## DIVAC

Diaphragm Vacuum Pumps

## SCROLLVAC

Scroll Vacuum Pumps

## ECODRY plus

Multi-Stage Roots Vacuum Pumps

## LEYVAC / DRYVAC / SCREWLINE / VARODRY

Screw Vacuum Pumps

## CLAWVAC

Claw Vacuum Pumps and Systems

220.00.02

Excerpt from the Leybold Full Line Catalog (Edition 2022)

Catalog Part Dry Compressing Vacuum Pumps

# Contents

## Dry Compressing Vacuum Pumps

### Global Versions

#### Diaphragm Vacuum Pumps DIVAC .....4

##### General

DIVAC Program Overview ..... 4

The customized Diaphragm Pump and the Accessories recommended for your Applications ..... 5

Modular Diaphragm Pump System for the Chemical Laboratory ..... 5

##### Products

#### Diaphragm Vacuum Pumps for Chemical Laboratories ..... 6

Dual-Stage Diaphragm Vacuum Pumps DIVAC 0.6 L, 1.2 L, 2.2 L ..... 6

Three-Stage Diaphragm Vacuum Pumps DIVAC 1.4 HV3C ..... 8

#### Dry Compressing Backing Pumps for Turbomolecular Pumps ..... 10

DIVAC 0.8 T to 4.8 VT ..... 10

DIVAC 0.8 T and 0.8 LT ..... 12

DIVAC 1.4 HV3 and 3.8 HV3 ..... 14

DIVAC 4.8 VT ..... 16

#### Scroll Vacuum Pumps SCROLLVAC ..... 18

##### Products

Oil-free Scroll Vacuum Pumps SCROLLVAC 7 plus to 18 plus ..... 18

#### Multi-Stage Roots Vacuum Pumps ECODRY plus ..... 22

##### General

Applications for ECODRY plus Pumps ..... 22

##### Products

Multi-stage Roots vacuum pumps ECODRY 25 to 65 plus ..... 23

#### Screw Vacuum Pumps LEYVAC ..... 27

##### General

Applications for LEYVAC Pumps ..... 27

##### Products

LEYVAC LV 80 and LV 140 ..... 28

**Screw Vacuum Pumps DRYVAC.....32**

**General**

Applications for DRYVAC Pumps ..... 32  
 Oil for DRYVAC pumps for different pump types ..... 32  
 Oil for DRYVAC pumps for different fields of application ..... 33

**Products**

DRYVAC DV 200 to DV 1200 -i..... 34

**Screw Vacuum Pumps SCREWLINE.....47**

**General**

Applications for SCREWLINE Pumps..... 47

**Products**

Screw Vacuum Pumps SCREWLINE SP 250 to SCREWLINE SP 630 (F)..... 48

**Screw Vacuum Pumps VARODRY .....58**

**Products**

Dry Screw Vacuum Pumps VARODRY ..... 58  
 Heavy Duty Models VARODRY VD HD/O<sub>2</sub> ..... 58  
 VARODRY OEM VARODRY DOT ..... 64

**Dry Claw Pumps and Systems CLAWVAC.....66**

**Products**

Dry Claw Pumps and Systems CLAWVAC..... 66  
 Dry Claw Pumps CLAWVAC CP 65 to CP 300 ..... 67  
 Over-Pressure Claw Pumps CLAWVAC OP 150 to OP 300 ..... 70  
 Dry Vacuum Claw Pump Systems CPi 600 / 900 / 1200..... 72

## DIVAC Program Overview

This range of vacuum pumps was developed especially for laboratory operations and as backing pumps for (wide range) turbomolecular pumps. It satisfies the highest expectations in terms of precision, reliability and ease of use.

The DIVAC line of vacuum pumps is the logical continuation of diaphragm pump technology which has proven its quality in decades of service.

### Laboratory Pumps

Through the laboratory pumps and the three different pumping speeds available for the same base pressure and through the modular design, the optimum pump system can be implemented for every application.

DIVAC L diaphragm pumps are suited for almost all requirements in the chemistry lab. They are basically corrosion and solvent resistant since their parts in contact with the pumped medium are made of PTFE (Teflon), FFPM (Kalrez) and PVDF (Solef).

### Backing Pumps

The DIVAC T range of diaphragm pumps comprises backing pumps which are used in all applications requiring an especially low base pressure while having to maintain an oil-free vacuum.

The DIVAC T pumps have been specially developed as backing pumps for wide range high vacuum turbomolecular pumps. They meet the requirements for a dry vacuum and a long service life.

DIVAC T pumps may be used both free-standing and integrated in applications or certain devices, and for this reason they are used in the areas of mass spectrometry, analytical and in general applications.

### Application Examples

#### Laboratory Pumps

- Vacuum filtration
- Vacuum distillation
- Vacuum drying
- To extract and transfer gases
- On rotary evaporators
- Gel drying

#### Backing Pumps

- Backing pump for wide range turbomolecular pumps
- Mass spectrometry
- Medicine technology
- Analytical technology
- General rough and medium vacuum applications

# The customized Diaphragm Pump and the Accessories recommended for your Applications

Modular diaphragm pump system	DIVAC 0.6 L	DIVAC 1.2 L	DIVAC 2.2 L	DIVAC 1.4 HV3C	DIVAC 0.8 T	DIVAC 0.8 TL	DIVAC 1.4 HV3	DIVAC 3.8 HV3	DIVAC 4.8 VT
<b>Applications</b>									
Evacuating small devices (e.g. desiccator)	■	■	■	■					
Sublimation	■	■	■	■					
Analysis preparation	■	■	■	■					
Filtration	■	■	■	■					
Distillation	■	■	■	■					
Drying in the drying cabinet			■	■					
Drying cabinets (2 cabinets with 1 pump)			■	■					
Rotary evaporator		■	■	■					
Backing pumps for wide range turbomolecular pumps				■	■	■	■	■	■
Mass spectrometry				■	■	■	■	■	■
Medical technology				■	■	■	■	■	■
Analytical technology				■	■	■	■	■	■
General applications in the rough and medium vacuum range	■	■	■	■	■	■	■	■	■

## Modular Diaphragm Pump System for the Chemical Laboratory

### Advantages to the User

- Low base vacuum of 8 mbar (6 Torr) for two-stage and 2 mbar (1.5 Torr) for three-stage DIVAC
- All parts of the pump head in contact with the gas are resistant against aggressive media through the use of PTFE (Teflon), FFPM (Kalrez) and PVDF (Solef)
- Dry compressing, oil-free
- Water vapor tolerance
- Low maintenance costs and long service intervals through the use of high-quality components which are well-proven
- Simple maintenance by staff of the customer
- Low noise operation
- Portable, compact, small footprint
- Can be operated in any orientation
- Overheat protection for the vacuum pump by means of a thermal fuse
- Available in four pumping speed categories

# Products

## Diaphragm Vacuum Pumps for Chemical Laboratories

### Dual-Stage Diaphragm Vacuum Pumps DIVAC 0.6 L, 1.2 L, 2.2 L



#### Typical Applications

Vacuum generation for

- Rotary evaporators
- Drying chambers
- Filtration units
- Distillation configurations
- Gel dryers

Dual-stage diaphragm vacuum pumps DIVAC 0.6 L, 1.2 L, 2.2 L

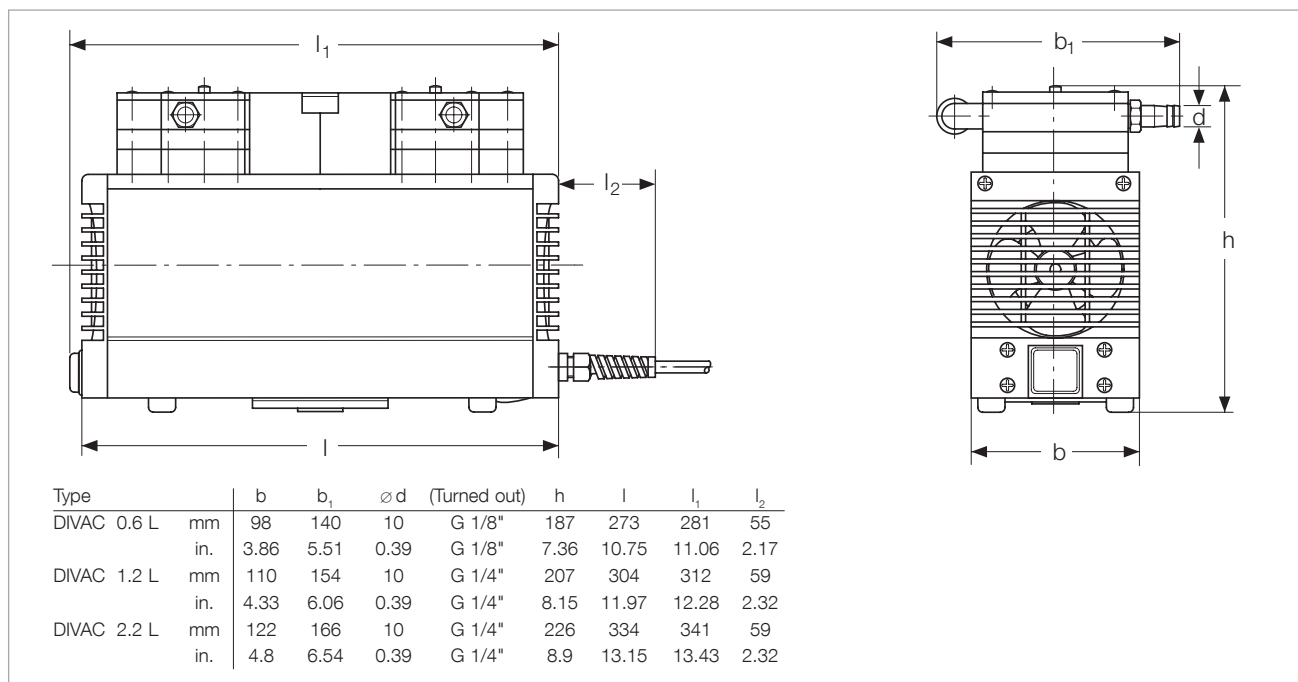

Dimensional drawing for the DIVAC 0.6 L, 1.2 L, 2.2 L

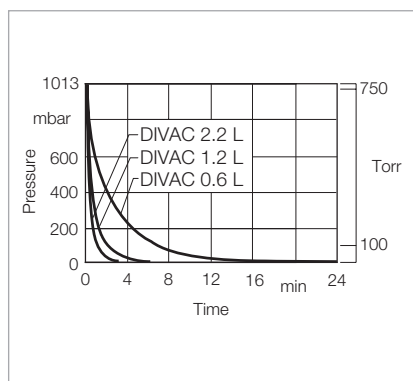

Curves of pump-down time of a 10 l vessel

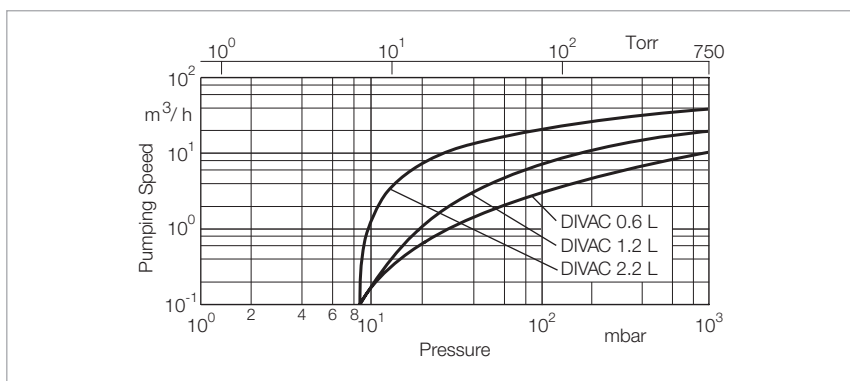

Curves of pumping capacity

**Technical Data**
**DIVAC**

		<b>0.6 L</b>	<b>1.2 L</b>	<b>2.2 L</b>
Max. pumping speed (atm.)	m <sup>3</sup> /h <sup>1</sup> (cfm)	0.6 (0.4)	1.2 (0.7)	2.0 (1.2)
Ultimate pressure	mbar (Torr)	≤ 8 (≤ 6)		
Max. exhaust back pressure (absolute)	mbar (Torr)	2000 (1500)		
Pump heads		2		
Connection				
Inlet (suction side)	DN	Hose nozzle ID 10	Hose nozzle ID 10	Hose nozzle ID 10
Exhaust (delivery side)	DN	Hose nozzle ID 10	Hose nozzle ID 10	Hose nozzle ID 10
Thread (suction and delivery side)	G	G 1/8"	G 1/4"	G 1/4"
Noise level acc. to DIN 45 635 Part 13, approx.	dB(A)	47	50	52
Permissible gas admission temperature, max.	°C (°F)	+5 to +40 (+41 to +104)		
Permissible ambient temperature, max.	°C (°F)	+5 to +40 (+41 to +104)		
Voltage / nominal frequency (1-ph. motor)				
Schuko plug	V / Hz	230 ± 10% / 50		
NEMA plug	V / Hz	115 ± 10% / 60		
NEMA plug	V / Hz	100 ± 10% / 50/60		
Protective class	IP	44		
Motor power <sup>1)</sup>	W	90	120	245
Current consumption <sup>1)</sup>	A	0,6	0,7	1,8
Motor speed				
50 Hz	min <sup>-1</sup>	1500		
60 Hz	min <sup>-1</sup>	1800		
Dimensions (W <sup>1)</sup> x H <sup>1)</sup> x D), approx	mm (in.)	281 x 140 x 187 (11.06 x 5.51 x 7.36)	312 x 154 x 207 (12.28 x 6.06 x 8.15)	341 x 166 x 226 (13.43 x 6.54 x 8.9)
Weight, approx.	kg (lbs)	6.9 (15.2)	9.3 (20.5)	12.6 (27.8)
Material				
Pump head		PTFE (Teflon)		
Structured diaphragm		PTFE coated		
Valves		FFPM (Kalrez)		
Nozzles		PVDF (Solef)		

**Ordering Information**
**DIVAC**

	<b>0.6 L</b>	<b>1.2 L</b>	<b>2.2 L</b>
	<b>Part No.</b>	<b>Part No.</b>	<b>Part No.</b>
Diaphragm vacuum pump 230 V, 50 Hz, with 2.3 m (8 ft) power cord and Schuko plug	<b>135 00</b>	<b>135 06</b>	<b>135 12</b>
Diaphragm vacuum pump 100 V, 50/60 Hz, with 2.3 m (8 ft) power cord and NEMA plug	-	-	<b>135 14</b>
Spare parts kit consisting of 2 diaphragms, 4 gasket rings, 4 valve plates	<b>EK135 23</b>	<b>EK135 24</b>	<b>EK135 25</b>
Hose nozzle kit consisting of 2 hose nipples, piping	-	<b>200 650 06</b>	<b>200 650 07</b>

<sup>1)</sup> For 230 V, 50 Hz version

# Three-Stage Diaphragm Vacuum Pumps DIVAC 1.4 HV3C



The DIVAC 1.4 HV3C is a three-stage diaphragm pump capable of resisting chemicals and offering an improved pumping performance. Its speed is infinitely variable from 700 to 1600 rpm so that the pumping speed of the pump can be easily adapted to differing requirements. The built-in textured diaphragm is PTFE coated. The valves are made of FPM thereby ensuring excellent resistance also in connection with aggressive gases. Owing to the three-stage design, pressures of 2 mbar can be attained very easily.

Three-stage diaphragm vacuum pump DIVAC 1.4 HV3C

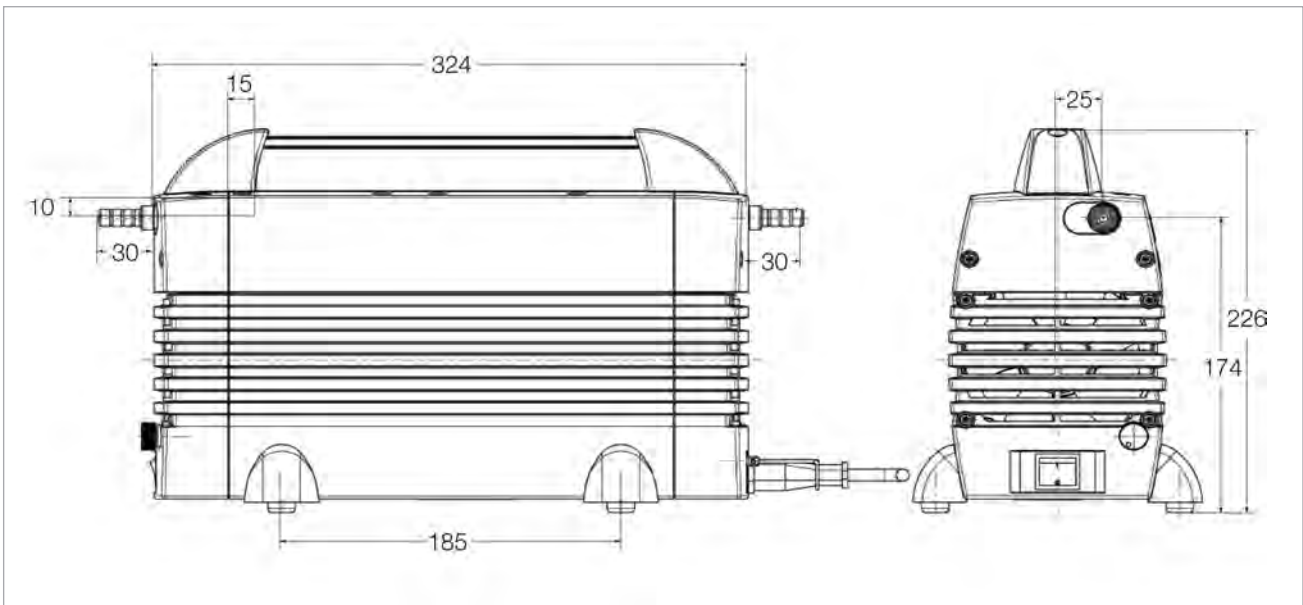

Dimensional drawing for the DIVAC 1.4 HV3C

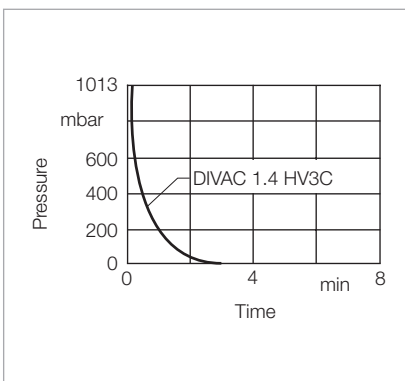

Curves of pump-down time of a 10 l vessel

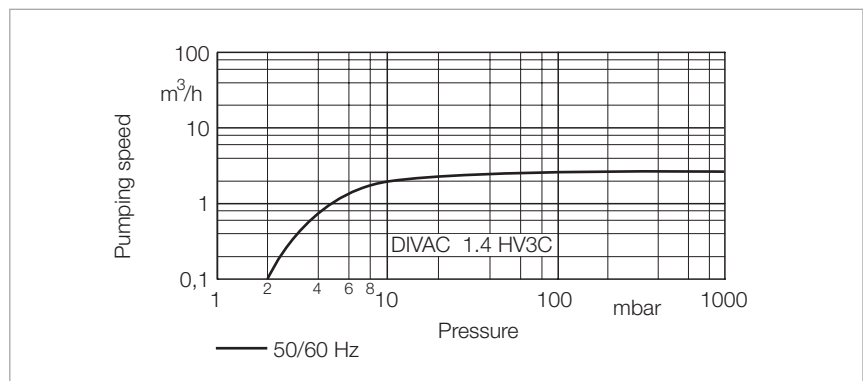

Curves of pumping capacity

**Technical Data**
**DIVAC 1.4 HV3C**

Max. pumping speed	m <sup>3</sup> /h <sup>1</sup> (cfm)	1.3 (0.77)
Ultimate pressure	mbar (Torr)	≤ 2.0 (≤ 1.5)
Max. exhaust back pressure (absolute)	mbar (Torr)	1500 (1125)
Pump heads		3
Connection		
Inlet (suction side)	DN	Hose nozzle ID 10
Exhaust (delivery side)	DN	Hose nozzle ID 10
Thread (suction and delivery side)	G	G 1/8"
Noise level acc. to DIN 45 635 Part 13, approx.	dB(A)	48
Permissible gas admission temperature, max.	°C (°F)	+5 to +40 (+41 to +104)
Permissible ambient temperature, max.	°C (°F)	+5 to +40 (+41 to +104)
Voltage / nominal frequency	V / Hz	90 – 230 / 50 – 60
Protective class	IP	20
Motor power <sup>1)</sup> at ultimate pressure	W	135
	W	35
Current consumption <sup>1)</sup>	A	1.3
Motor speed	min <sup>-1</sup>	700 to 1600
Dimensions (W <sup>1)</sup> x H <sup>1)</sup> x D), approx	mm (in.)	324 x 158 x 226 (12.76 x 6.22 x 8.90)
Weight, approx.	kg (lbs)	8.6 (18.99)
Material		
Pump head		PPS
Structured diaphragm		PTFE coated
Valves		FFPM
Nozzles		PVDF

**Ordering Information**
**DIVAC 1.4 HV3C**

	Part No.
Diaphragm vacuum pump 90 – 230 V, 50 – 60 Hz, with 2.3 m (8 ft) power cord and Schuko plug	<b>135 20 V</b>
Accessories Exhaust silencer 1.4 with connection G 1/8"	<b>127 90 A</b>

<sup>1)</sup> For 230 V, 50 Hz version

# Dry Compressing Backing Pumps for Turbomolecular Pumps

## DIVAC 0.8 T to 4.8 VT



Our dry compressing backing pumps from the DIVAC T series are now supplemented by the three-stage DIVAC 1.4 HV3 and the DIVAC 3.8 HV3. Like the proven DIVAC T series, these new models also ensure a forevacuum free of hydrocarbons. Owing to their three-stage design, they provide especially within the lower pressure ranges a higher pumping speed and are therefore even better suited as backing pumps for turbomolecular pumps. But they are also used as backing pumps operating in the rough and medium vacuum range to pump clean media.

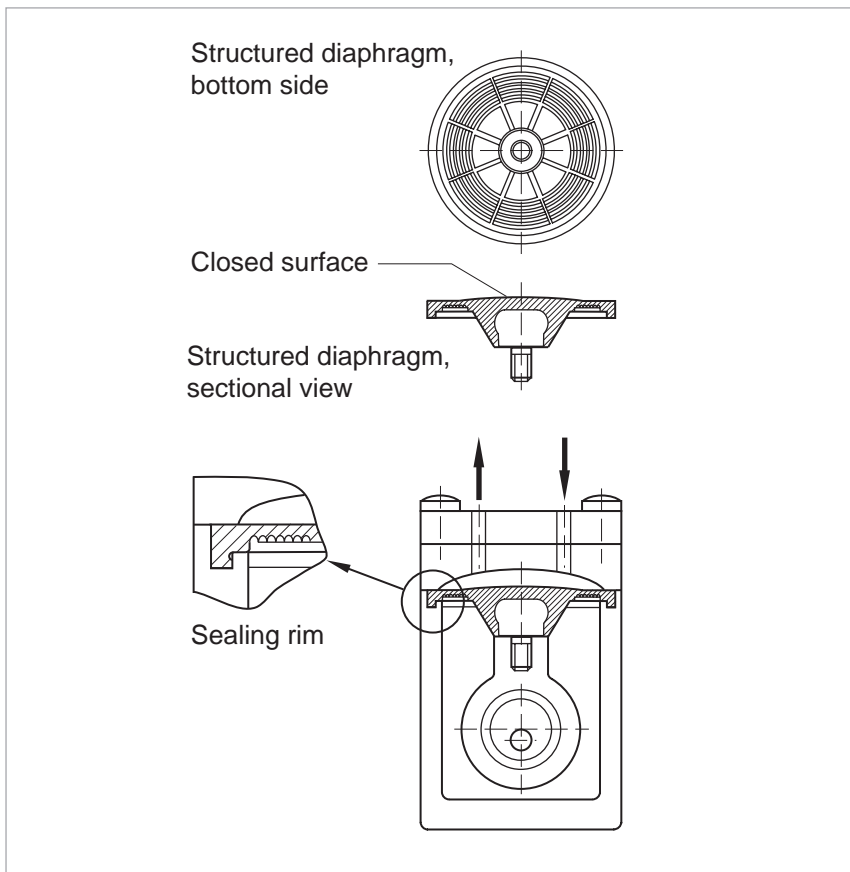

Diaphragm pump with structured diaphragm

The structured diaphragm with its sealed surface provides the basis for a long service life and a low base pressure.

### Advantages to the User

- Dry compressing, free of oil and hydro-carbons
- Matched to the turbomolecular pumps from Leybold (SL 80 to TURBOVAC 450i)
- Low ultimate pressure
- ISO-KF flange at the intake port
- Fully equipped with cable, switch (ON/OFF) and plug
- Better performance and smaller size through the use of structured diaphragms
- Low vibration levels through dynamic mass balancing (in VT pumps)
- Lower maintenance costs and long maintenance intervals through the use of high-quality and well-proven components
- Simple maintenance
- Favourable price-to-performance ratio
- Can be operated in any position

### Typical Applications

- Backing pump for wide pressure range turbomolecular pumps
- Mass spectrometers
- Medical equipment
- Analyzes
- For laboratory applications also with corrosive media
- General use for rough and fine vacuum applications

# DIVAC 0.8 T and 0.8 LT



DIVAC 0.8 T



DIVAC 0.8 LT

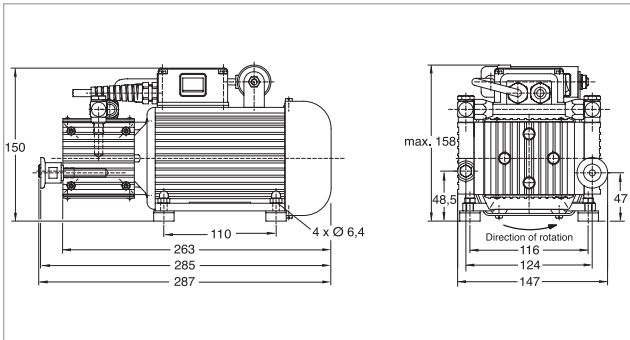

Dimensional drawing for the DIVAC 0.8 T

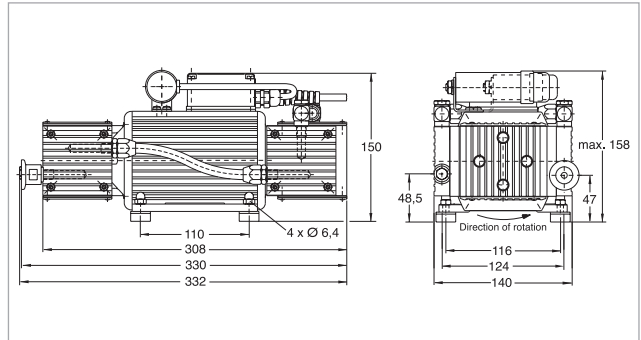

Dimensional drawing for the DIVAC 0.8 LT

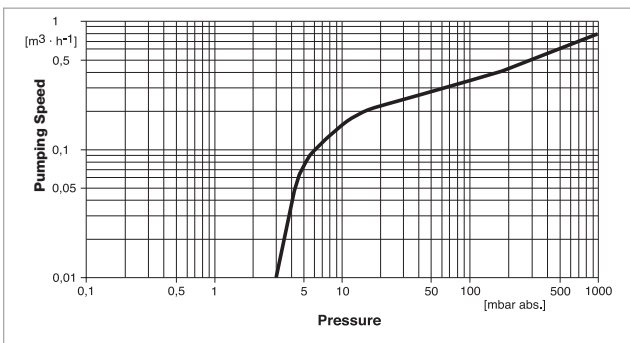

Pumping speed curve of the DIVAC 0.8 T

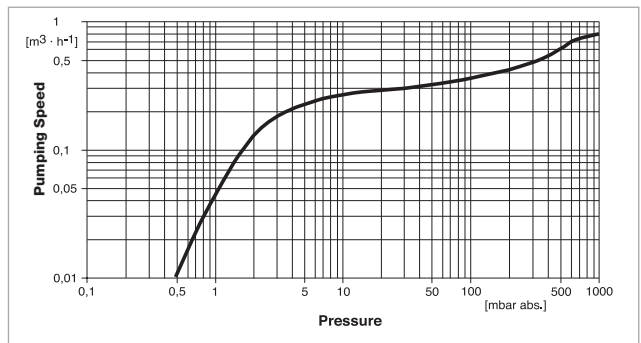

Pumping speed curve of the DIVAC 0.8 LT

**Technical Data**
**DIVAC**

		<b>0.8 T</b>	<b>0.8 LT</b>
Max. pumping speed (atm.)	m <sup>3</sup> /h <sup>1</sup> (cfm)	0.77 (0.45)	
Ultimate pressure	mbar (Torr)	≤ 3.0 (≤ 2.25)	≤ 0.5 (≤ 0.38)
Max. exhaust back pressure (absolute)	mbar (Torr)	2000 (1500)	
Pump heads		2	4
Connection		16 KF Silencer G 1/8"	
Inlet (suction side)	DN		
Exhaust (delivery side)	DN		
Thread (suction and delivery side)	G		
Noise level acc. to DIN 45 635 Part 13, approx.	dB(A)	49	53
Permissible gas admission temperature, max.	°C (°F)	+5 to +40 (+41 to +104)	
Permissible ambient temperature, max.	°C (°F)	+5 to +40 (+41 to +104)	
Voltage / nominal frequency (1-ph. motor)			
Schuko plug	V / Hz	198 – 264 / 50/60	230 / 50 ± 10%
NEMA plug	V / Hz	90 – 127 / 50/60	115 / 60 ± 10%
Protective class	IP	44	
Motor power <sup>1)</sup>	W	50	80
Current consumption <sup>1)</sup>	A	0.4	0.5
Nominal speed, approx. (50/60 Hz)	min <sup>-1</sup>	1500/1800	
Dimensions (W <sup>1)</sup> x H <sup>1)</sup> x D), approx	mm (in.)	285 x 150 x 150 (11.22 x 5.9 x 5.9)	332 x 150 x 150 (13.07 x 5.9 x 5.9)
Weight, approx.	kg (lbs)	5.9 (13.02)	7.5 (16.56)
Material		Aluminum Neoprene EPDM	
Pump head			
Diaphragm			
Valves			

**Ordering Information**
**DIVAC**

	<b>0.8 T</b>	<b>0.8 LT</b>
	<b>Part No.</b>	<b>Part No.</b>
Diaphragm vacuum backing pumps for turbomolecular pumps including 1 m (3.5 ft) long mains cord, country-specific plug, silencer, rubber feet, as well as ON/OFF switch 198 – 264 V / 50/60 Hz 230 V ± 10% / 50 Hz 90 – 127 V / 50/60 Hz	<b>127 80</b> – <b>127 81</b>	– <b>127 83</b> –
Spare parts kit consisting of 2 diaphragms, 4 valves, 4 valve gaskets, 4 piping gaskets	<b>EK 127 95</b>	<b>EK 127 95 (2x)</b>
Exhaust silencer	<b>127 98</b>	<b>127 98</b>

T = For use in connection with Turbomolecular pumps

L = Very low ultimate pressure (Low pressure)

V = Low vibration levels (Low Vibration)

# DIVAC 1.4 HV3 and 3.8 HV3



DIVAC 1.4 HV3



DIVAC 3.8 HV3

The three-stage DIVAC 1.4 HV3 and the DIVAC 3.8 HV3 provide especially in the lower pressure range a higher pumping speed compared to conventional diaphragm pumps. At the same time they are capable of attaining ultimate pressures below 2 mbar (1.5 Torr) and are thus very well suited as backing pumps for turbomolecular pumps. Owing to their compact design they are also suited for installation within pump systems.

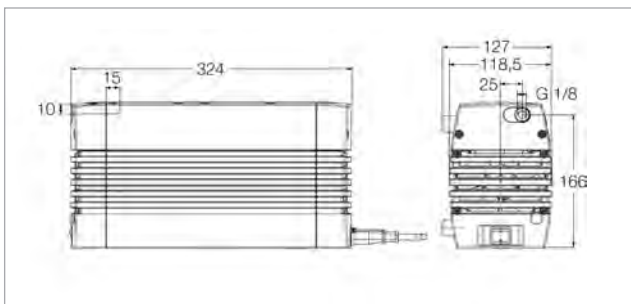

Dimensional drawing for the DIVAC 1.4 HV3

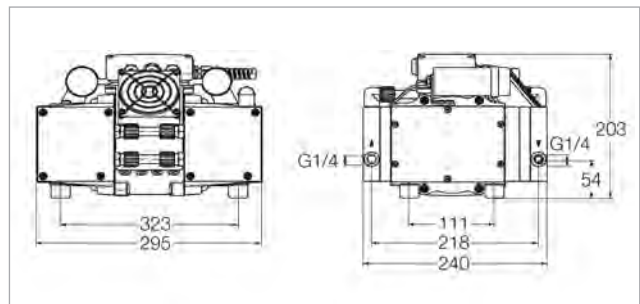

Dimensional drawing for the DIVAC 3.8 HV3

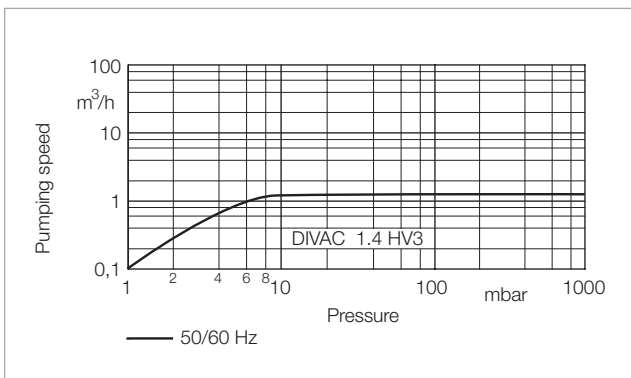

Pumping speed curve of the DIVAC 1.4 HV3

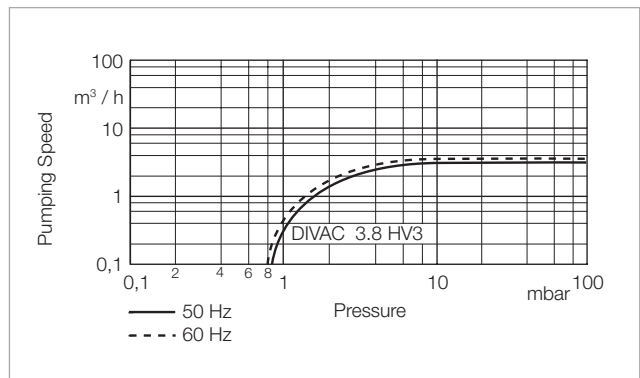

Pumping speed curve of the DIVAC 3.8 HV3

**Technical Data**
**DIVAC**

		1.4 HV3	3.8 HV3
Max. pumping speed			
50 Hz	m <sup>3</sup> /h <sup>1</sup> (cfm)	1.3 (0.77)	3.4 (2.00)
60 Hz	m <sup>3</sup> /h <sup>1</sup> (cfm)	–	3.8 (2.24)
Ultimate pressure	mbar (Torr)	≤ 1.5 (≤ 1.13)	≤ 1.0 (≤ 0.75)
Max. exhaust back pressure (absolute)	mbar (Torr)	1500 (1125)	
Pump heads		3	
Connection			
Inlet (suction side)	DN	Hose nozzle ID 9	Hose nozzle ID 9
Exhaust (delivery side)	DN	Hose nozzle ID 9	Hose nozzle ID 9
Thread (suction and delivery side)	G	G 1/8"	G 1/4"
Noise level acc. to DIN 45 635 Part 13, approx.	dB(A)	48	54
Permissible gas admission temperature, max.	°C (°F)	+5 to +40 (+41 to +104)	
Permissible ambient temperature, max.	°C (°F)	+5 to +40 (+41 to +104)	
Voltage / nominal frequency (1-ph. motor)			
Schuko plug	V / Hz	90 – 230 / 50-60	90 – 230 / 50-60
NEMA plug	V / Hz	–	115 / 50-60
Protective class	IP	20	
Motor power <sup>1)</sup>	W	120	250
at ultimate pressure	W	35	190
Current consumption <sup>1)</sup>	A	1.3	1.7
Nominal speed, approx. (50/60 Hz)	min <sup>-1</sup>	1500	1500/1800
Dimensions (W <sup>1)</sup> x H <sup>1)</sup> x D), approx	mm (in.)	324 x 158 x 226 (12.76 x 6.22 x 8.90)	295 x 240 x 203 (11.61 x 9.45 x 7.99)
Weight, approx.	kg (lbs)	10.5 (23.18)	18.9 (41.72)
Material		Aluminum	
Pump head		EPDM	
Structured diaphragm		EPDM	
Valves		PA	
Nozzles			

**Ordering Information**
**DIVAC**

	1.4 HV3	3.8 HV3
	Part No.	Part No.
Diaphragm vacuum backing pumps for turbomolecular pumps including 1 m (3.5 ft) long mains cord, country-specific plug, silencer, rubber feet, as well as ON/OFF switch		
90 – 230 V / 50 – 60 Hz	<b>127 90 V</b>	–
230 V / 50 – 60 Hz	–	<b>127 95 V</b>
115 V / 50 – 60 Hz	–	<b>127 96 V</b>
Exhaust silencer		
1.4 with connection G 1/8"	<b>127 90 A</b>	–
3.8 with connection G 1/4"	–	<b>127 95 A</b>
Spare parts kit	<b>EK057456</b>	<b>EK12768</b>

# DIVAC 4.8 VT

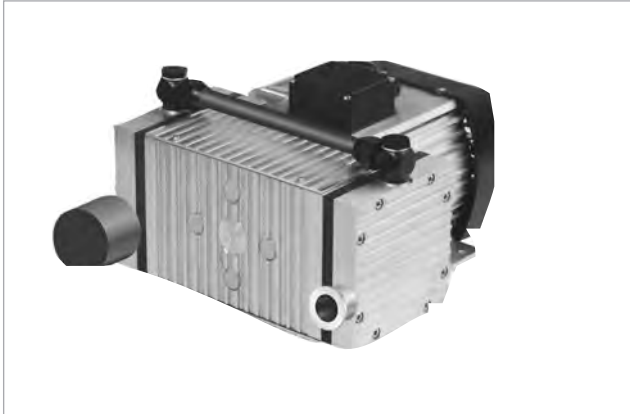

DIVAC 4.8 VT

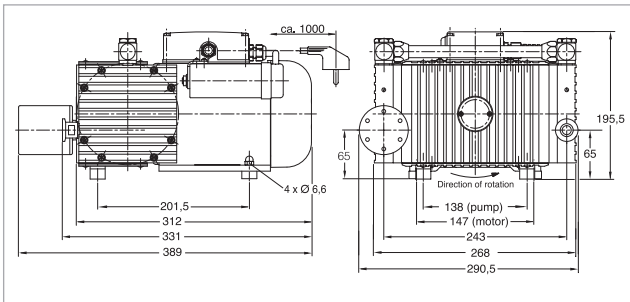

Dimensional drawing for the DIVAC 4.8 VT

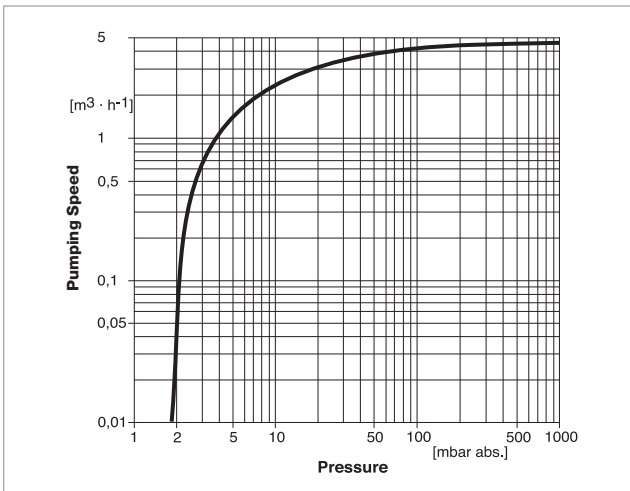

Pumping speed curve of the DIVAC 4.8 VT

**Technical Data**
**DIVAC 4.8 VT**

Max. pumping speed (atm.)	m <sup>3</sup> /h <sup>1</sup> (cfm)	4.8 (2.83)
Ultimate pressure	mbar (Torr)	≤ 2.0 (≤ 1.5)
Max. exhaust back pressure (absolute)	mbar (Torr)	2000 (1500)
Pump heads		2
Connection		
Inlet (suction side)	DN	16 KF
Exhaust (delivery side)	DN	Silencer
Thread (suction and delivery side)	G	G 3/8"
Noise level acc. to DIN 45 635 Part 13, approx.	dB(A)	55
Permissible gas admission temperature, max.	°C (°F)	+5 to +40 (+41 to +104)
Permissible ambient temperature, max.	°C (°F)	+5 to +40 (+41 to +104)
Voltage / nominal frequency (1-ph. motor)		
Schuko plug	V / Hz	230 / 50 ± 10%
NEMA plug	V / Hz	115 / 60 ± 10%
Protective class	IP	54
Motor power <sup>1)</sup>	W	350
Current consumption <sup>1)</sup>	A	2.6
Nominal speed, approx. (50 Hz)	min <sup>-1</sup>	1500
Dimensions (W <sup>1)</sup> x H <sup>1)</sup> x D), approx	mm (in.)	324 x 273 x 220 (12.76 x 10.75 x 8.66)
Weight, approx.	kg (lbs)	18.0 (39.74)
Material		
Pump head		Aluminum
Diaphragm		EPDM
Valves		Viton

**Ordering Information**
**DIVAC 4.8 VT**

	Part No.
Diaphragm vacuum backing pumps for turbomolecular pumps including 1 m (3.5 ft) long mains cord, country-specific plug, silencer, rubber feet, as well as ON/OFF switch 230 V ± 10% / 50 Hz	<b>127 92</b>
Spare parts kit consisting of 2 diaphragms, 4 valves, 4 valve gaskets, 4 piping gaskets	<b>EK 127 97</b>
Exhaust silencer	<b>127 94</b>

T = For use in connection with Turbomolecular pumps

L = Very low ultimate pressure (Low pressure)

V = Low vibration levels (Low Vibration)

# Products

## Oil-free Scroll Vacuum Pumps SCROLLVAC 7 plus to 18 plus



Scroll vacuum pump SCROLLVAC 15 plus

### Advantage for the User

- Flexibility for customer requirements
- Four different pumping speeds available as required for the application
- Single- and Three-phase configurations available
- High robustness for each application
- ATEX certification (**Ex II 3 G c IIB T4**)
- Variants for aggressive applications available (SCROLLVAC C plus)
- High water vapour capacity
- Electronic-free three-phase variant for reduced radiation sensitivity
- Better work environment and low environmental impact
- quiet operation
- Simple operation
- intelligent and easy to use controls
- No contamination and no oil to dispose of
- hermetically sealed for a lubricant-free vacuum environment
- Low cost of ownership
- long service interval and low power consumption from a single sided scroll arrangement
- Maximised up-time
- long service intervals

### Typical Applications

- General clean pumping applications
- Scanning Electron Microscopes - SEM
- Beam lines and high energy physics
- Research and development
- Backing turbomolecular pumps
- Centrifuges, ultra-high speed
- Chamber evacuation
- Chemical applications including gel dryers and solvent recovery

In 1905 the principle of the scroll compressor was developed by the Frenchman Leon Creux.

SCROLLVAC plus is the next generation in completely oil free, dry scroll pumps by offering increased pumping speeds, combined with lower ultimate pressures, lower power consumption and lower noise. Gas ballast allows for pumping of condensable vapours including, water, solvents, dilute acids and bases. SCROLLVAC plus pumps also feature the latest in tip seal technology giving significantly longer life between tip seal changes. Integrated inverter drive with auto sensing voltage input delivers optimised pumping performance globally.

SCROLLVAC plus pumps are designed to be completely field serviceable.

### Service

Our wide portfolio of services is designed with you in mind: to help keep your process and equipment running in the most economical and environmentally efficient manner.

Service include:

- Overhaul and repair using genuine Leybold OEM parts
- OEM spares and kits available for cost-effective expansion and backups
- Remanufactured products available for cost-effective expansions and backups
- Global network of expert field service engineers available to respond quickly to unexpected equipment failures

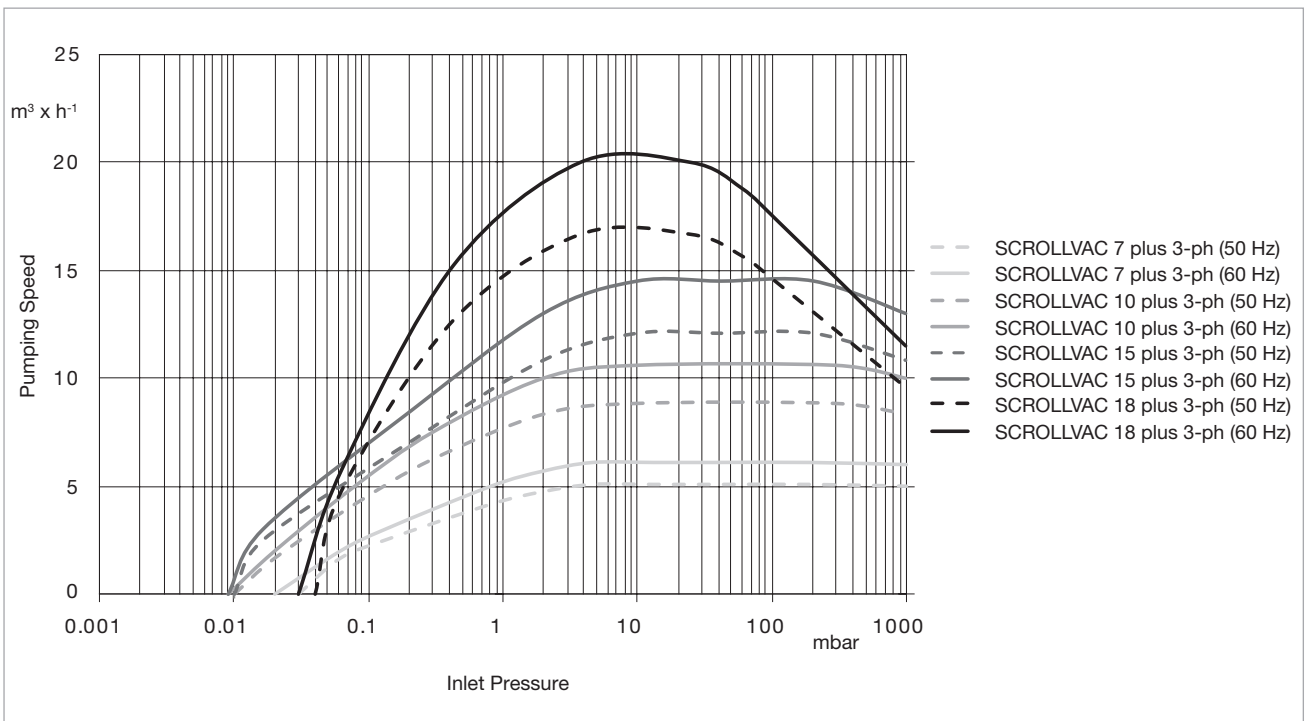
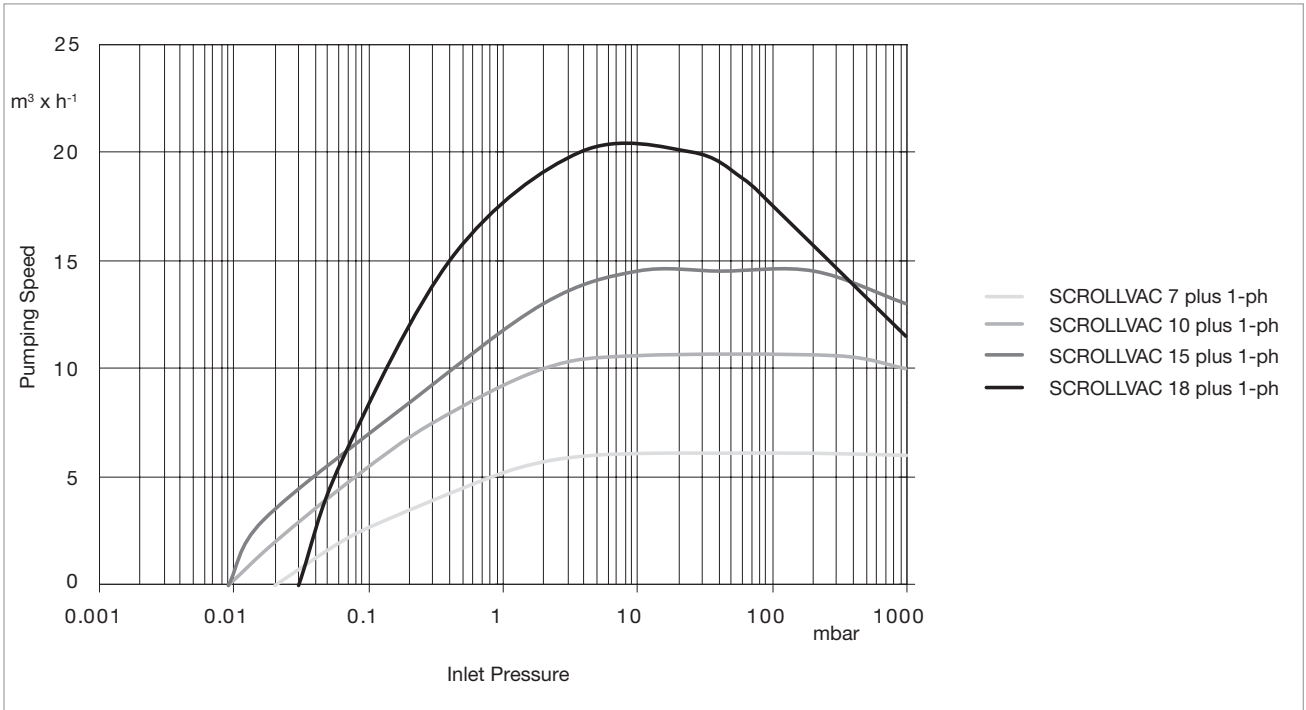

Pumping speed curves for the SCROLLVAC plus – pumps

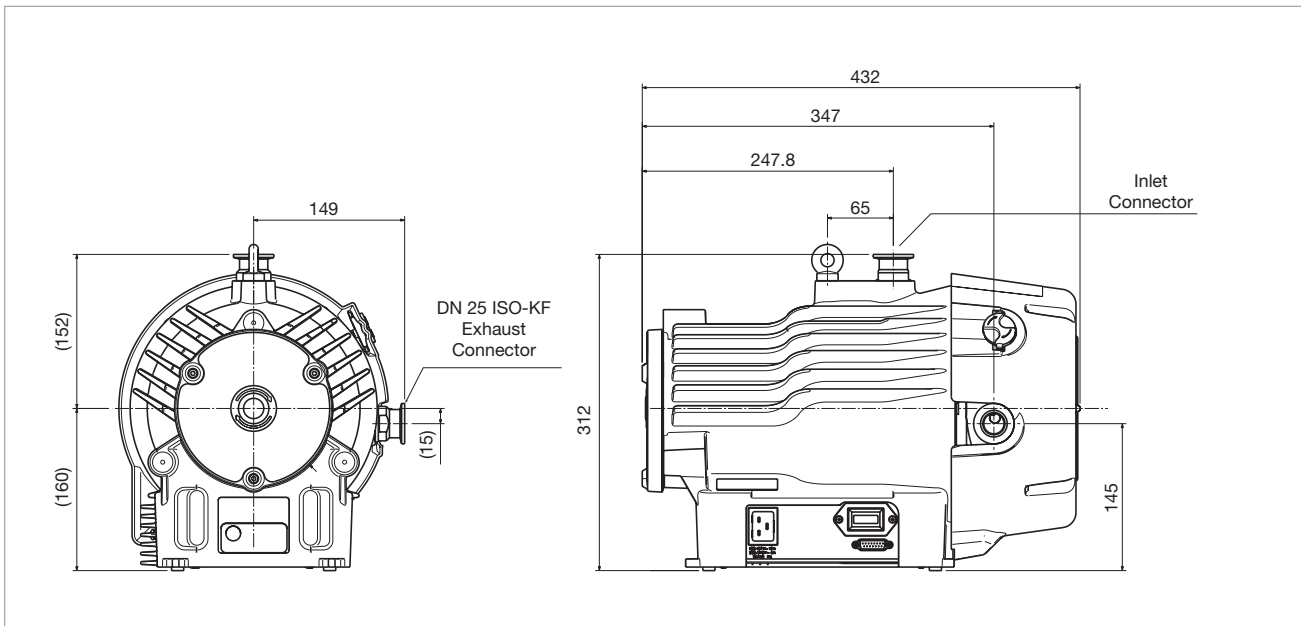

Dimensional drawing for the scroll vacuum pumps SCROLLVAC 7 plus to SCROLLVAC 18 plus (dimensions in mm)

## Technical Data

## SCROLLVAC plus

		7	10	15	18
Rotation speed	rpm	1740			
Max. pumping speed	m <sup>3</sup> /h	6.1	10.6	14.5	20.0
Ultimate vacuum (total pressure)	mbar (Torr)	$2 \times 10^{-2}$ ( $1.5 \times 10^{-2}$ )	$9 \times 10^{-3}$ ( $6.5 \times 10^{-3}$ )	$9 \times 10^{-3}$ ( $6.5 \times 10^{-3}$ )	$3 \times 10^{-2}$ ( $2.25 \times 10^{-3}$ )
Maximum water vapour pumping rate (with gas ballast)	g/h	100	140	280	220
Maximum continuous inlet pressure	mbar	200			
Mains voltage 1-ph	V	100 – 127, 200 – 240 ( $\pm 10\%$ )			
Mains voltage 3-ph	V	200 / 380 – 415, 200 – 230 / 460			
Frequency	Hz	50/60			
Motor power (at ultimate pressure)	W	260	280	300	260
Power connector 1-ph		IEC EN60320 C19			
Weight	kg (lb)	26 (58)	25 (56)	26 (58)	25 (56)
Inlet flange		DN 25 ISO-KF			
Exhaust flange		DN 25 ISO-KF			
Noise level	dB(A)	55			
Leak tightness (Static)	mbar x l/s	$1 \times 10^{-6}$			
Operating temperature range	°C (°F)	10 to 40 / 41 to 104			

## Ordering Information

## SCROLLVAC plus

	<b>7</b>	<b>10</b>	<b>15</b>	<b>18</b>
	<b>Part No.</b>	<b>Part No.</b>	<b>Part No.</b>	<b>Part No.</b>
Oil-free scroll vacuum pump, Single-phase motor *				
Standard (with manual gas ballast)	<b>141007V10</b>	<b>141010V10</b>	<b>141015V10</b>	<b>141018V10</b>
C-Version (for aggressive applications)	-	-	<b>141015V12</b>	<b>141018V12</b>
Oil-free scroll vacuum pump, Three-phase motor *				
Standard (with manual gas ballast)	-	<b>141010V30</b>	<b>141015V30</b>	<b>141018V30</b>
C-Version (for aggressive applications)	-	<b>141010V32</b>	<b>141015V32</b>	<b>141018V32</b>
<b>Accessories Mains cable (required for pump operation)</b>				
Mains cable Europe				
CEE 7/7 (Schuko) – IEC-60320 C19				
Length 2.0 m	<b>161810EU</b>			
Mains cable Great Britain				
BS 1363 – IEC-60320 C19				
Length 2.0 m	<b>161810UK</b>			
Mains cable US				
115 V: NEMA 5-15P – IEC-60320 C19				
Length 3.0 m	<b>141103US</b>			
208/230 V: NEMA 6-15P – IEC-60320 C19				
Length 2.5 m	<b>161810US</b>			
<b>Optional accessories</b>				
Gas ballast adaptor blank (H-conversion KIT)	<b>141100A01</b>			
Gas ballast adaptor for external gas line – no restriction (Quick connect 1/4 inch)	<b>141100A02</b>			
Gas ballast adaptor for external gas line – with fine restriction (Quick connect 1/4 inch)	<b>141100A03</b>			
Chemical resistance conversion kit (C-conversion KIT)	<b>141101A01</b>	<b>141101A01</b>	<b>141101A01</b>	<b>141101A02</b>
Vibration isolators	<b>141102A01</b>			
Silencer	<b>141102A02</b>			
Minor Service Kit				
Standard (with manual gas ballast)	<b>EK117141000</b>	<b>EK117141000</b>	<b>EK117141000</b>	<b>EK117141001</b>
C-Version (for aggressive applications)	<b>EK117141002</b>	<b>EK117141002</b>	<b>EK117141002</b>	<b>EK117141003</b>

\* Other pump variants on request

## Applications for ECODRY plus Pumps

<b>Pumps</b>	ECODRY 25 plus	ECODRY 35 plus	ECODRY 40 plus	ECODRY 65 plus
<b>Application</b>				
Mass spectrometry	■	■	■	■
Electron microscopy	■	■	■	■
Vacuum drying			■	■
Particle accelerators / Synchrotron	■	■	■	■
Spectroscopy	■	■	■	■
Regeneration of cryo pumps			■	■
Backing pumps for turbomolecular pumps	■	■	■	■
Surface analysis	■	■	■	■

## Multi-stage Roots vacuum pumps ECODRY 25 to 65 plus



The ECODRY plus is a family of dry-compression multi-stage Roots vacuum pumps, which sets new standards in noise reduction. The pumps have been specially designed for use in quiet and clean environments, such as analysis and research laboratories.

### Operating principle

The multi-stage Roots pump is a further development of the tried-and-tested Roots pump principle. Two contactless rotating rotors turn in contrary motion within a single pump housing. The rotors do not come into contact with one another, or with the pump housing. Through their rotation, they convey the gas from the intake flange on the upper side to the outlet aperture on the underside of the suction chamber. Several pumping stages are arranged one behind the other on one axis to achieve high compression. The outlet apertures are connected to the respective intake aperture of the ensuing chamber via channels in the pump housing. The pump's operating range extends from the medium vacuum range to ambient pressure.

Short channels between the compression stages, combined with a very high rotational speed, make a compact construction with simultaneously high suction capacity possible. Lubrication takes place only in the shaft bearing regions. These are separated from the suction chamber by means of a wear-free sealing system, such that no lubricant can find its way into the suction chamber or into the vacuum chamber.

### Low-noise operation

During the design phase, particular emphasis was placed on reducing the pumps' noise levels. The rotors' high manufacturing quality guarantees that the pumps will run with a low level of vibration, and consequently with a low level of noise, even at high inlet pressures. Efficient noise insulation is integrated within the pump housing, to shield the user from residual noise. The silencer integrated within the exhaust region further serves to minimize noise, even at high gas flow rates. These measures combine to achieve a noise level of less than 52 dB(A) – quieter than a normal conversation

### Clean environment

Thanks to the oil-free suction chamber, no lubricant can enter the vacuum chamber or the area surrounding the pump from the interior of the pump. Furthermore, because the rotors operate contact-free, no abrasion debris are created in the form of particles, which could contaminate the vacuum chamber. In the case of the pump itself, this guarantees long-term stable operation with no deterioration in final pressure or suction capacity.

### Ease of commissioning

The ECODRY plus models have a compact housing and are simple to operate. With integrated castors and their low weight, they can be easily rolled out of their packaging and on to their installation location. There is no need for elaborate power cabling, as the pumps can be connected directly to a single-phase electricity supply. The pumps are air-cooled, and therefore require no connection to a water supply for the purposes of cooling.

### Maintenance-free operation

ECODRY plus features a friction-free operating principle, so their components are not exposed to wear in any way. All ECODRY plus components are designed for up to five years' operation. Maintenance measures such as replacing seals or changing the oil are not required during that time.

## High water vapour tolerance

In drying applications, such as cryo-pump regeneration, or when pumping out vacuum chambers with large surface areas, high quantities of water vapour may accrue. Not every pump can handle this without difficulty, as condensation in the pump can lead to corrosion and pump failure. However, with its gas ballast valve open, the ECODRY plus can pump water vapour at rates of up to 500 g/h without internal condensation. Because the manually operated gas ballast inlet has an

integrated silencer, the pump is quieter than any of its competitors in these applications also.

## Benefits at a glance

- Quietest pump in its class – it won't disturb your work
- Clean vacuum generation with no contamination of workstation or vacuum chamber
- Many years of maintenance-free operation without deterioration of vacuum parameters

## Typical applications

- Mass spectrometry
- Electron microscopy
- Backing pump for turbomolecular pumps
- Drying
- Accelerator/synchrotron
- Spectroscopy
- Regeneration of cryopumps
- Surface analysis

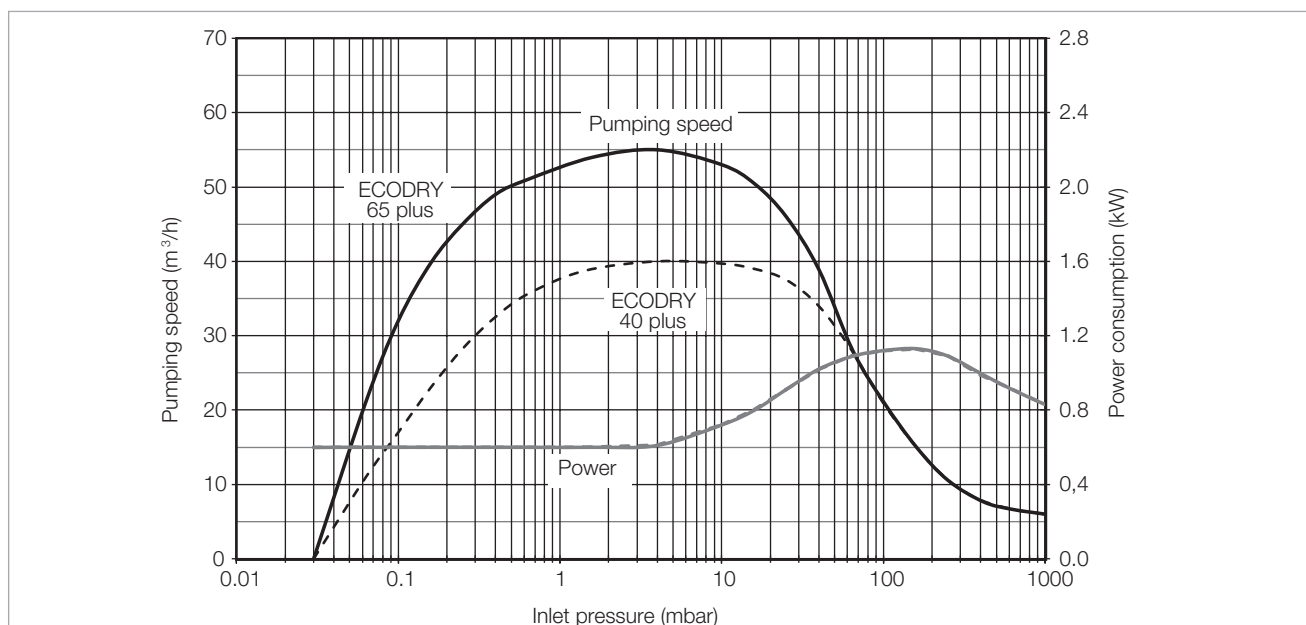
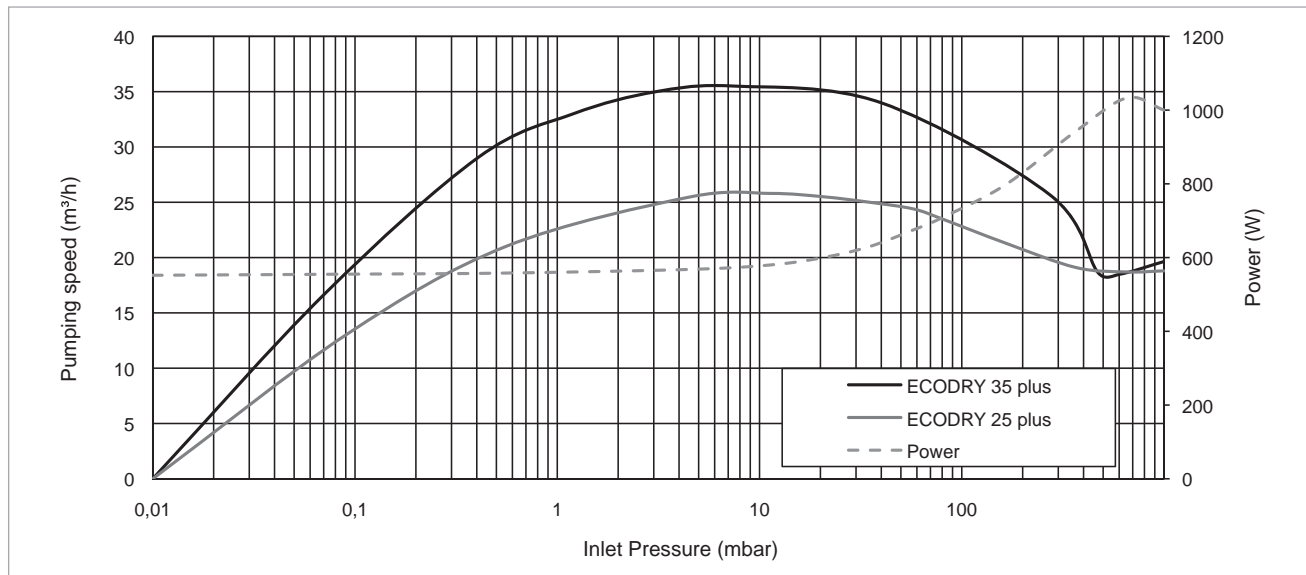

Pumping speed curves for the ECODRY plus - pumps

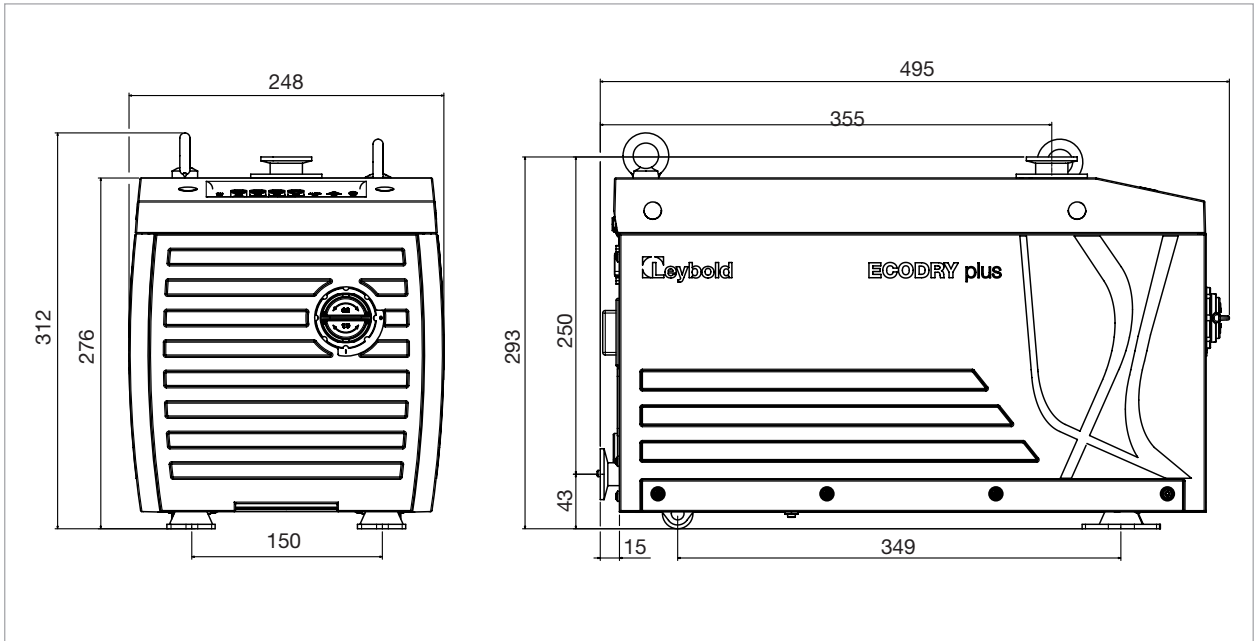

Dimensional drawing for the ECODRY 25 and 35 plus, all dimensions in mm

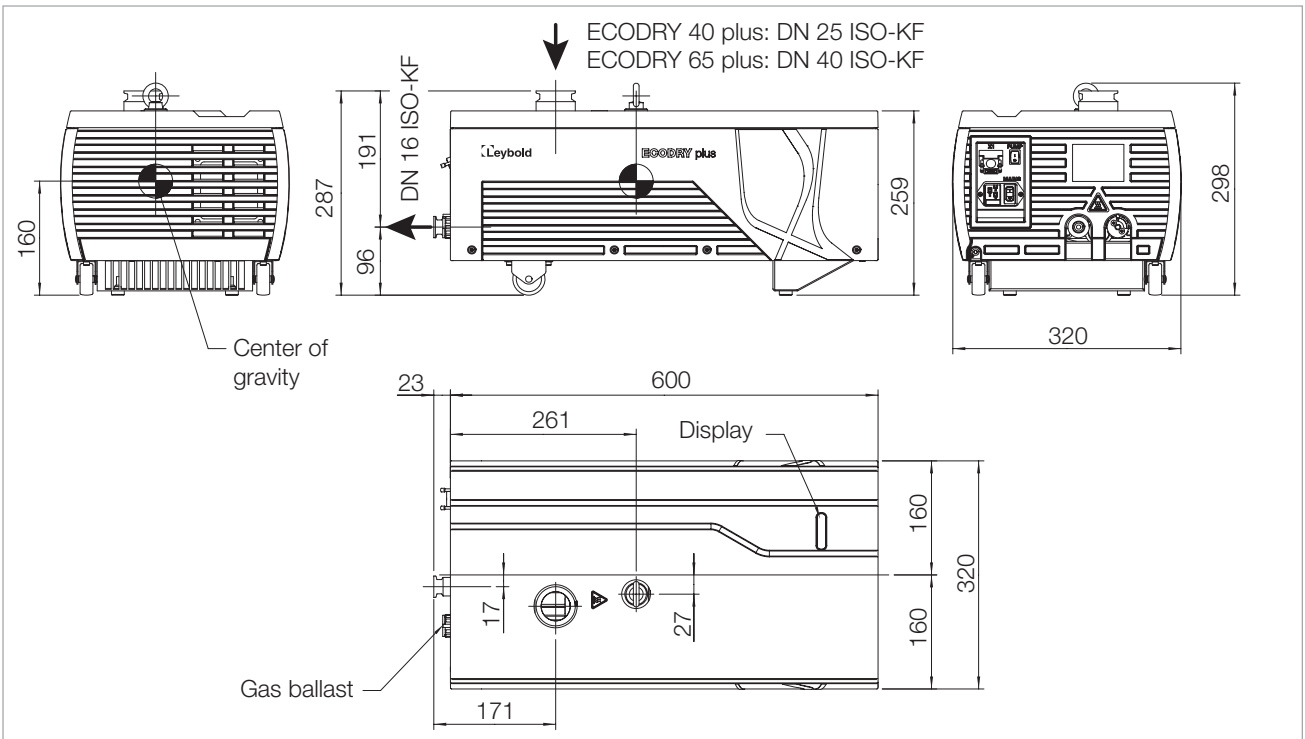

Dimensional drawing for the ECODRY 40 and 60 plus, all dimensions in mm

## Technical Data

## ECODRY

		25 plus	35 plus	40 plus	65 plus
Maximum pumping speed without gas ballast	m <sup>3</sup> /h	25	35	40	55
Ultimate pressure without gas ballast	mbar	< 0.01		< 0.03	
Ultimate pressure with gas ballast	mbar	< 0.1			
Leak rate	mbar l/s	< 10 <sup>-6</sup>		< 10 <sup>-5</sup>	
Water vapour tolerance with gas ballast	mbar	20			
Water vapour capacity with gas ballast	g/h	200	300	300	500
Maximum permissible inlet pressure	mbar	1013		1050	
Permissible ambient temperature	°C	+5 to +40			
Max. installation height (up to NHN)	m	3000		2000 (to 3000 m at reduced inlet pressure)	
Cooling		Air			
Mains voltage	V	100-127 V / 200-240 V (switchable) ± 10%		200 – 240 ± 10%	
Frequency	Hz	50/60			
Phases		1-ph			
Max. power consumption	W	1000		1200	
Power consumption at ultimate pressure	W	600			
Plug connector for power supply		C 20 acc. to IEC 60320			
Protection class	IP	21		42	
Intake flange		DN 25 ISO-KF	DN 25 ISO-KF	DN 25 ISO-KF	DN 40 ISO-KF
Outlet flange		DN 25 ISO-KF		DN 16 ISO-KF	
Weight, approx.	kg	28		43	
Dimensions (L x W x H)	mm	495 x 248 x 293		623 x 320 x 298	

## Ordering Information

## ECODRY

	25 plus	35 plus	40 plus	65 plus
	<b>Part No.</b>	<b>Part No.</b>	<b>Part No.</b>	<b>Part No.</b>
Dry Compressing Vacuum Pump ECODRY plus				
High voltage: 200-240 V (± 10%), 50/60 Hz	-	-	<b>161 040 V22</b>	<b>161 065 V22</b>
Low voltage: 120 V (± 10%), 50/60 Hz	-	-	<b>161 040 V21</b>	<b>161 065 V21</b>
Far range: 100-127 V / 200-240V (± 10%)	<b>162 025 V001</b>	<b>162 035 V001</b>	-	-
<b>Inlet screens</b>				
DN 25 ISO-KF	<b>E41170206</b>	<b>E41170206</b>	<b>E41170206</b>	-
DN 40 ISO-KF	-	-	-	<b>E41170121</b>
<b>Accessories</b>				
<b>Mains cables (mandatory accessories)</b>				
EU (CEE 7/7 – C19, 2.0 m)			<b>161 810 EU</b>	
UK (BS 1363 – C19, 2.0 m)			<b>161 810 UK</b>	
US 120 V only (NEMA 5-15P – C19, 2.0 m)			<b>141 103 US</b>	
US 200-240 V only (NEMA 6-15P – C19, 2.5 m)			<b>161 810 US</b>	
<b>other accessories</b>				
Casing assembly mounting kit	<b>162 800 A001</b>		<b>161 831 A</b>	
RS485/USB connecting cable for X104 interface, 1.8 m			<b>161 820 USB</b>	
Gas ballast blank plug	<b>141 100 A01</b>		<b>161 832 A</b>	
Purge gas adapter			<b>161 833 A</b>	
full flow	<b>141 100 A02</b>			
limited to 0.75 slm	<b>141 100 A03</b>			
				-

# General

## Applications for LEYVAC Pumps

Dry compressing vacuum pumps	LEYVAC LV 80	LEYVAC LV 80 C	LEYVAC LV 80 CC	LEYVAC LV 140	LEYVAC LV 140 C	LEYVAC LV 140 CC
<b>Applications</b>						
<b>Process industry</b>						
Industrial furnaces	■	■	■	■	■	■
Degassing	■	■	■	■	■	■
Charging	■	■	■	■	■	■
Casting	■	■	■	■	■	■
Drying processes in general				■	■	■
Freeze drying	■	■	■	■	■	■
Packaging	■	■	■	■	■	■
Electron beam welding	■	■	■	■	■	■
<b>Coating</b>						
PVD / CVD coating	■	■	■	■	■	■
Wear protection	■	■	■	■	■	■
Optical coating	■	■	■	■	■	■
Web coating	■	■	■	■	■	■
Lock / Transfer chambers	■	■	■	■	■	■
<b>Solar</b>						
CVD / PECVD	■	■	■	■	■	■
Crystal pulling and casting	■	■	■	■	■	■
<b>Support functions</b>						
Regeneration of cryo pumps	■	■	■	■	■	■
Forevacuum pumps for Turbomolecular pumps	■	■	■	■	■	■

# Products

## LEYVAC LV 80 and LV 140

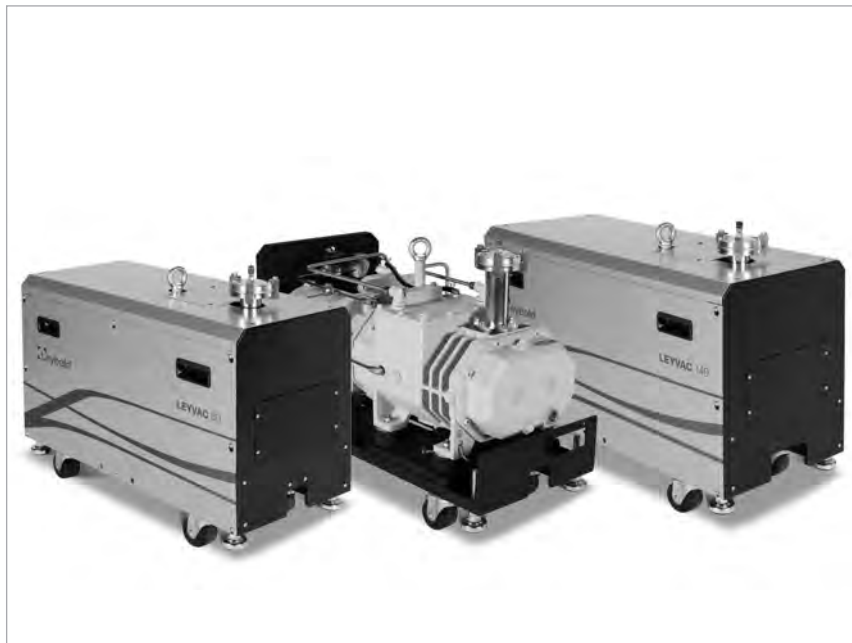

LEYVAC LV 80 and 140

**Our LEYVAC dry vacuum pumps provide power combined with high performance.**

This product line covers the pumping speed ranges from 80 to 160 m<sup>3</sup>/h and is especially suited to meet the special requirements of industrial processes and coating applications.

LEYVAC pumps and system combinations are rugged, reliable and durable, ready to cope with harsh process requirements.

The LEYVAC product line comprises the models LEYVAC LV 80, LV 140, and their C or CC versions.

The CC versions include an overtemperature safety shutdown facility.

### Advantages to the User

- Dry pump technology
- No contact of the process gases with oil
- Shortest pumpdown times through high pumping speed for air already starting at atmospheric pressure
- Hermetically tight
  - No shaft seals
  - No oil leakage
  - Safe pumping of toxic gases
- High reliability
  - Long service intervals (up to 5 years)
  - High uptime
  - Robust and durable design
- One motor solution
  - Multi-voltage, dual frequency motor operable at 200 V - 460 V and 50/60 Hz
- Easy and modular
  - Direct coupling of roots booster pumps without frames for models RUVAC WH 700 and WA(U)/WS(U) 251-1001

### Typical Application

- Process industry
  - Industrial furnaces
  - Degassing
  - Charging
  - Casting
  - Drying processes
  - Freeze drying
  - Electron beam welding
  - Packaging
- Coating
  - PVD/CVD coating
  - Wear resistant coating
  - Optical coating
  - Web coating
  - Load locks/transfer chambers
- Solar
  - CVD/PECVD
  - Crystal pulling and casting
- Support functions
  - Regeneration of cryo pumps
  - Forevacuum pumps for turbomolecular pumps

### Performance Details at a Glance

LEYVAC dry vacuum pumps provide **optimized**

- System uptime
  - Robust design based on the proven RUVAC and DRYVAC technology
  - Most effective cooling system
  - Thermal protection on board (for CC versions)
  - Tolerant to pressure shocks
  - Long intervals for bearing exchange
- Process safety
  - designed for harsh applications
- Performance data
  - High pumping speed already at high intake pressures
  - Good pumping speed also for lighter gases (with purge)
- Environmental properties
  - Low noise and low heat emission
- Price-to-performance ratio
  - Low investment costs
  - Small, price optimized pumping systems

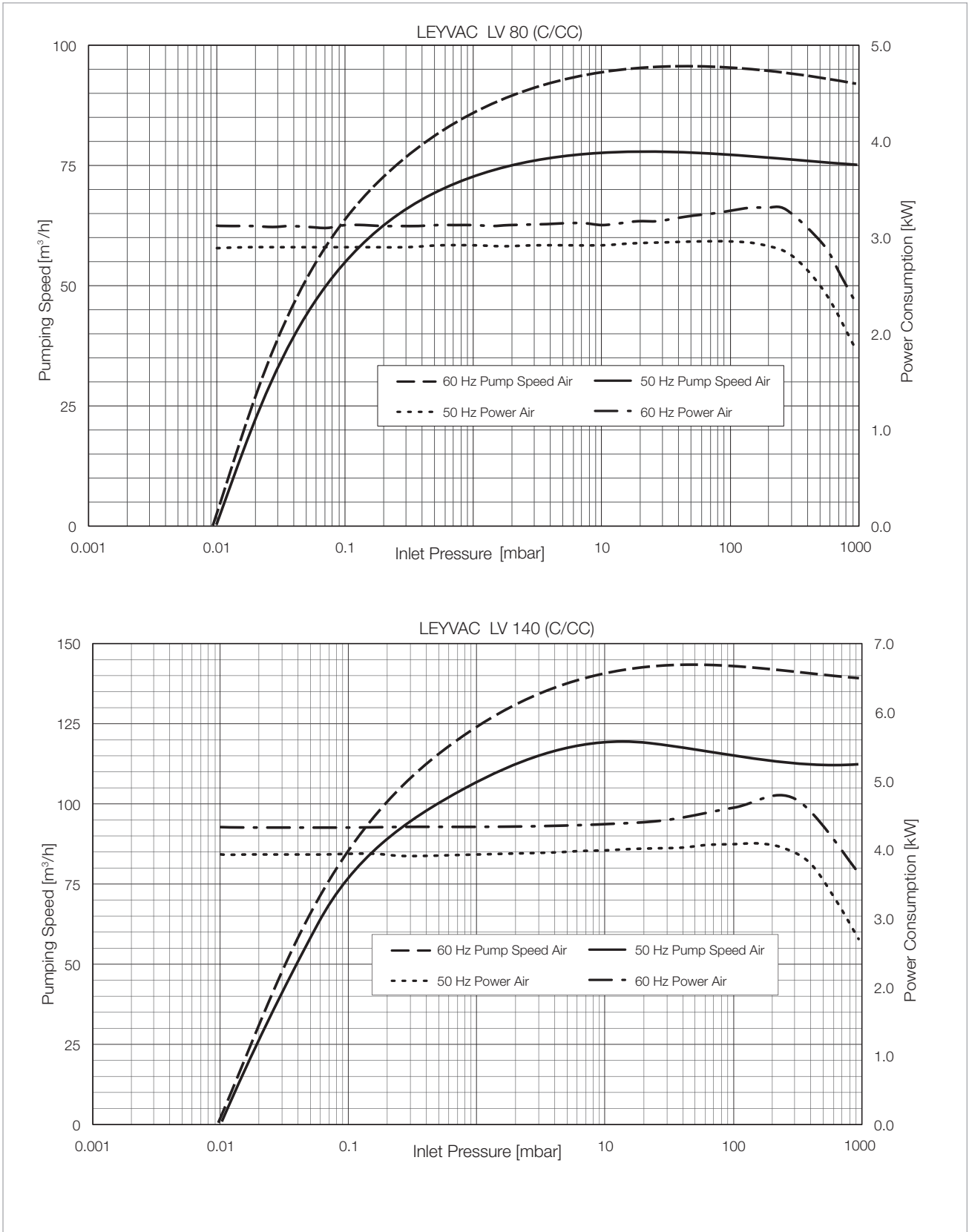

Pumping speed curves of the LEYVAC LV 80 (C/CC) and LEYVAC LV 140 (C/CC)

## Technical Data

## LEYVAC

		LV 80 (C/CC)	LV 140 (C/CC)
Nominal pumping speed without gas ballast at 50/60 Hz	m <sup>3</sup> /h (cfm)	80/96 (47.1/56.5)	125/145 (73.6/85.3)
Ultimate pressure with seal and rotor purge	mbar (Torr)	1 x 10 <sup>-2</sup> (0.75 x 10 <sup>-2</sup> )	
Power consumption at ultimate pressure and 50/60 Hz operation	kW (hp)	2.9/3.2 (3.9/4.3)	3.9/4.3 (5.2/5.8)
Weight, approx.			
LV ..	kg (lbs)	280 (617)	300 (661)
LV ... C/CC	kg (lbs)	300 (661)	320 (705)
Noise level <sup>1)</sup>	dB(A)	< 65	< 65
Connection flange			
Intake	DN	63 ISO-K	
Discharge	DN	40 ISO-KF	
Mains voltage (± 10%)			
LV ...	V	200 – 460	
LV ... C (with housing)	V	200 – 460	
LV ... CC (with housing and Temperature monitoring)	V	380 – 460	
Nominal power at 50/60 Hz	kW (hp)	4.1 (5.5)	5.5 (7.4)
Nominal current consumption 50/60 Hz bei 400 V	A	6	8
Cooling		water/glycol	
Cooling water temperature	°C (°F)	+15 to +30 (+59 to +86)	
Min. cooling water throughput	l/min	3	
Water vapor tolerance (with gas ballast)			
80 slm 50/60 Hz	mbar (Torr)	20/30	125/160
150 slm 50/60 Hz <sup>2)</sup>	mbar (Torr)	-/-	-/-
Water vapor capacity (with gas ballast)			
80 slm 50/60 Hz	kg/h	1,24/2,3	11,5/18,0
150 slm 50/60 Hz <sup>2)</sup>	kg/h	-/-	-/-
Permissible ambient temperature	°C (°F)	+5 to +45 (+41 to +113)	
Protection class EN 60529	IP	54	
Dimensions (W x H x D)			
LV ... and LV ... C	mm (in.)	814 x 375 x 550 (32.05 x 14.76 x 21.65)	895 x 400 x 567 (35.24 x 15.75 x 22.32)
LV ... CC	mm (in.)	984 x 375 x 550 (38.74 x 14.76 x 21.65)	1065 x 400 x 567 (41.93 x 15.75 x 22.32)

<sup>1)</sup> At ultimate pressure and with rigid exhaust line DIN EN ISO 2151

<sup>2)</sup> 2nd case: with 24 V gas ballast kit 115005A13 fitted to port 2, standard purge also opened

Type	b	b <sub>1</sub>	b <sub>2</sub>	h	h <sub>1</sub>	h <sub>2</sub>	h <sub>3</sub>	h <sub>4</sub>	h <sub>5</sub>	l (CC version)	l <sub>1</sub>	l <sub>2</sub>	l <sub>3</sub>	l <sub>4</sub>	l <sub>5</sub>	
LV 80 (C)	mm	375	320	266	550	576	266	266	341	191	814 (984)	335	265	402	485	410
	in.	14.76	12.60	10.47	21.65	22.68	10.47	10.47	13.43	7.52	32.05 (38.74)	13.19	10.43	15.83	19.09	16.14
LV 140 (C)	mm	400	350	285	567	597	257	257	332	182	895 (1065)	364	297	453	514	439
	in.	15.75	13.78	11.22	22.32	23.50	10.12	10.12	13.07	7.17	35.24 (41.93)	14.33	11.69	17.84	20.24	17.28

Dimensional drawing for the LEYVAC LV 80/C and LV 140/C; below for exhaust connection

## Ordering Information

## LEYVAC

### LV 80 (C/CC)

### LV 140 (C/CC)

	Part No.	Part No.
Dry compressing vacuum pump LEYVAC including LEYBONOL LVO 410 lubricant, base plate, castors, temperature switch, shaft seal and rotor purge	<b>15080V15</b>	<b>115140V15</b>
including LEYBONOL LVO 210 lubricant	<b>115080V40</b>	<b>115140V40</b>
additionally with casing (C version)	<b>115080V30</b>	<b>115140V30</b>
additionally with casing and temperature monitoring (CC version)	<b>115080V35</b>	<b>115140V35</b>
<b>Accessories</b>		
Non-return ball valve	<b>115005A01</b>	<b>115005A01</b>
Non-return valve, spring-loaded	<b>115005A02</b>	<b>115005A02</b>
Roots pump adapter for RUVAC WS/WSU 251/501 and WH 700	<b>115005A03</b>	<b>115005A03</b>
Adapter ring for RUVAC WA(U)/WS(U)1001	—	<b>115005A04 and 115005A03</b>
Exhaust pressure sensor LV 80	<b>115005A10</b>	—
LV 140	—	<b>115005A11</b>
Gas ballast kit manually operated 24 V	<b>115005A12</b> <b>115005A13</b>	<b>115005A12</b> <b>115005A13</b>
Silencer standard (with integrated non-return valve) serviceable emptyable	<b>115005A20</b> <b>115005A22</b> <b>115005A23</b>	<b>115005A20</b> <b>115005A22</b> <b>115005A23</b>
High-performance silencer	<b>115005A21</b>	<b>115005A21</b>
Elbow for silencer, emptyable	<b>115005A26</b>	<b>115005A26</b>
Inlet screen	<b>115005A28</b>	<b>115005A28</b>
External frequency converter (including mains filter) for LEYVAC LV 80 (400 V)	<b>115005A30</b>	—
LEYVAC LV 80 (200 V)	<b>115005V31</b>	—
LEYVAC LV 140 (400 V)	—	<b>115005A35</b>
LEYVAC LV 140 (200 V)	—	<b>115005V36</b>
Profibus module <sup>1)</sup>	<b>155212V</b>	<b>155212V</b>
Relais module (digital output) <sup>1)</sup>	<b>112005A01</b>	<b>112005A01</b>
Ethernet interface module <sup>1)</sup>	<b>112005A02</b>	<b>112005A02</b>
ProfiNet module <sup>1)</sup>	<b>112005A35</b>	<b>112005A35</b>
EtherCAT module <sup>1)</sup>	<b>112005A36</b>	<b>112005A36</b>

<sup>1)</sup> For optional, external frequency converter

# General

## Applications for DRYVAC Pumps

<b>Pumps</b>										
	DRYVAC DV 200	DRYVAC DV 300	DRYVAC DV 500	DRYVAC DV 650	DRYVAC DV 650 S	DRYVAC DV 650 C	DRYVAC DV 800	DRYVAC DV 1200	DRYVAC DV 1200 -i	
<b>Applications</b>										
Automotive industry	■	■	■	■			■	■	■	
Electrical engineering	■	■	■	■			■	■	■	
Energy technology	■	■	■	■		■	■	■	■	
Degassing	■	■	■	■			■	■	■	
Research and development	■	■	■	■		■	■	■	■	
Freeze drying	■	■	■	■		■	■	■	■	
Industrial gases	■	■	■	■		■	■	■	■	
Refrigeration and air conditioning	■	■	■	■			■	■	■	
Crystal pulling/casting	■	■	■	■		■	■	■	■	
Lamination	■	■	■	■		■	■	■	■	
Leak testing machines	■	■	■	■	■		■	■	■	
Loadlock chambers	■	■	■	■	■		■	■	■	
Metallurgy/Furnaces	■	■	■	■			■	■	■	
Plasma cleaning or activation	■	■	■	■		■	■	■	■	
Welding technology	■	■	■	■	■		■	■	■	
Sterilization	■	■	■	■		■	■	■	■	
Vacuum coating	■	■	■	■		■	■	■	■	
Vacuum drying	■	■	■	■	■		■	■	■	
Packaging	■	■	■	■			■	■	■	
Space simulation	■	■	■	■			■	■	■	
Wind turbines	■	■	■	■			■	■	■	
Backing pump for highvacuum systems	■	■	■	■			■	■	■	

## Oil for DRYVAC pumps for different pump types

<b>Pumps</b>										
	DRYVAC DV 200	DRYVAC DV 300	DRYVAC DV 500	DRYVAC DV 650	DRYVAC DV 650 S	DRYVAC DV 650 C	DRYVAC DV 800	DRYVAC DV 1200	DRYVAC DV 1200 -i	
<b>LEYBONOL Oils</b>										
LVO 210	■	■	■	■	■		■	■	■	
LVO 410	■				■	■			■	

■ = Standard

The table only lists general applications. Your specific requirements might be subject to deeper analysis. For further questions, please contact our technical Sales support.

**For information on oil specifications please refer to Catalog Part "Oils / Greases / Lubricants LEYBONOL®".**

# Oil for DRYVAC pumps for different fields of application

**LEYBONOL Oils**

	LVO 210	LVO 410
<b>Applications</b>		
Automotive industry	■	
Electrical engineering	■	
Energy technology	■	
Degassing	■	
Research and development	■	
Freeze drying	■	
Industrial gases	■	
Refrigeration and air conditioning	■	
Crystal pulling/casting	■	
Lamination	■	
Leak testing machines	■	
Loadlock chambers	■	
Metallurgy/Furnaces	■	
Plasma cleaning or activation	●	■
Welding technology	■	
Sterilization	■	
Vacuum coating	■	
Vacuum drying	■	
Packaging	■	
Space simulation	■	
Wind turbines	■	
Backing pump for highvacuum systems	■	
Oxygen processes		■
PECVD		■

- = Standard
- = Possible

The table only lists general applications. Your specific requirements might be subject to deeper analysis. For further questions, please contact our technical Sales support.

**For information on oil specifications please refer to Catalog Part "Oils / Greases / Lubricants LEYBONOL®".**

# Products

## DRYVAC DV 200 to DV 1200 -i

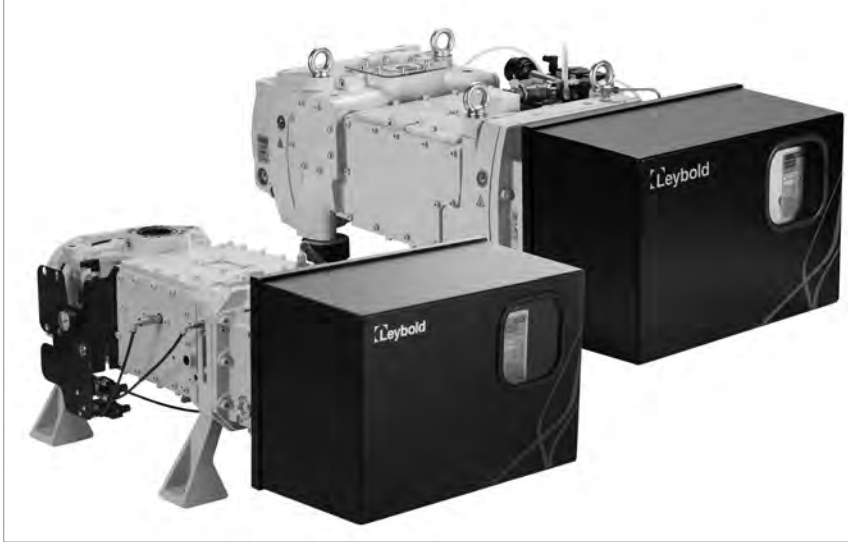

DRYVAC DV 200, DV 300, DV500 (left), DV 650, DV 800 (right)



DRYVAC DV 1200 -i

### DRYVAC – The benchmark in industrial vacuum processes

The DRYVAC dry screw pumps provide high pumping speeds down to the lowest vacuum pressure levels required in industrial processes. The pumps provide continuous production output in your stressful environment minimizing the risk of contamination thanks to modern oil-free technology.

If you already own a mechanical booster, consider that dry pumps have the same low level of requirement in terms of maintenance and service.

All DRYVAC variants are water cooled, very compact and easy to combine into systems, in particular with the well-proven Roots pumps of the RUVAC WH series.

Concerning basic and full blown plug & play system combination of DRYVAC and RUVAC please refer the chapter DRYVAC SYSTEMS DS.

### DRYVAC Versions

The DRYVAC-i versions and DS-i-Systems (see chapter DRYVAC Systems DS) expand the DRYVAC by an on board controller with a touch screen display and a user interface allowing plug&play operation and configuration.

Different interfaces are available: 24 V I/O, Profibus, Ethernet IP.

DRYVAC DV200 and DV 300 are for 200-240 Volts and for 380-460 Volts equipped with an on-boarded intelligent variable speed drive. They offer an automatically controlled vacuum side shaft seal purge and on the outside an I/O (15 pin Sub D) and RS485 interface (9 pin Sub-D). All other interfaces like Ethernet IP are available as optional cards. The DRYVAC speaks proverbial every language.

DRYVAC 650 with external variable speed drive (FC) are available on request. These are named DV – r.

The DRYVAC DV 650 200 V comes with an external variable speed drive (FC) as standard.

All DRYVAC DV 1200 come on a base plate with casters, adjustable feet and enclosure.

All DRYVAC S and C and DV 1200 versions comprise a water cooling unit which includes water distributions, a pressure reducer and an overpressure safety valve.

### Features and Benefits

#### Maintenance

- Minimal maintenance requirements lead to lowest cost of ownership
- Extended periods between user intervention
- Lower consumable costs

#### Performance

- Very stable pumping speed gives repeatability to processes
- Continuous pumping at atmosphere
- Ability to handle dust, vapors and process by-products
- Dry eliminates back-streaming, thus protecting reactive alloys from contamination

#### Design

- Superior and compact design
- Energy-efficient (benchmark in 300 and 650 class)
- Integrated variable speed drive cannot be harmed by industrial cooling water or dust
- Flexible to use (three inlet ports and low height)

#### Safety

- Low noise levels

## The best DRYVAC for every application

For industrial processes of all kinds, where rapid pumping down and short cycling (e.g. load locks) is required, the DRYVAC Industrial is the best solution.

The DRYVAC DV industrial versions (with **lubricant LVO 210, synthetic oil**) deliver an excellent pumping speed also in processes with pressures exceeding 100 mbar. They are suited for short cycle operation or for evacuation of large vacuum chambers.

The DRYVAC DV pumps are furthermore equipped with all features necessary for process industry applications (Purge gas unit including rotor purge or gas ballast for example).

In application with high oxygen concentrations, corrosive gasses or harsh PECVD processes pumps with **lubricant LVO 410 (PFPE)** are required. In these applications the DRYVAC DV C models are the right choice

## Typical Applications

- Metallurgy
- Coating
- Drying
- Solar
- Vacuum chamber evacuation
- Load lock

## Certifications

DRYVAC vacuum pumps are certified to NRTL and CSA according to UL 61010-1



## The DRYVAC series

comprises the models

- DRYVAC DV 200
  - DRYVAC DV 300
  - DRYVAC DV 500
  - DRYVAC DV 650
  - DRYVAC DV 650 Atex Cat. 2 I T2
  - DRYVAC DV 800
  - DRYVAC DV 1200
  - DRYVAC DV 1200 S-i
  - DRYVAC DV 1200 Atex Cat. 2 I T2
- and allows for numerous combinations with Roots pumps from the RUVAC series.



DRYVAC DS Systems with Roots Blowers RUVAC WAU 2001, WH 2500, WH 4400

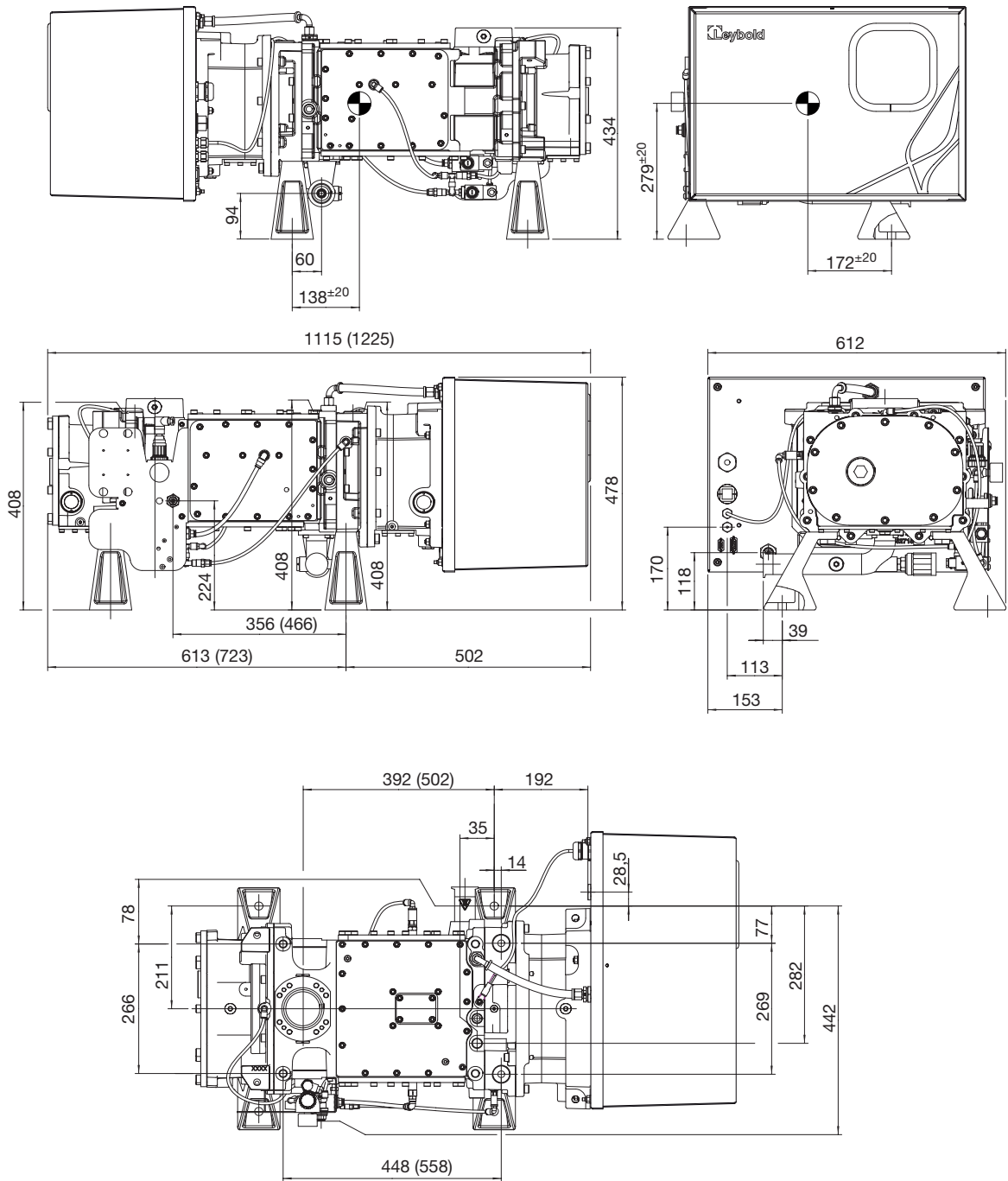

Dimensional drawing for the DRYVAC DV 200, DV300 and (DV 500), all dimensions in mm

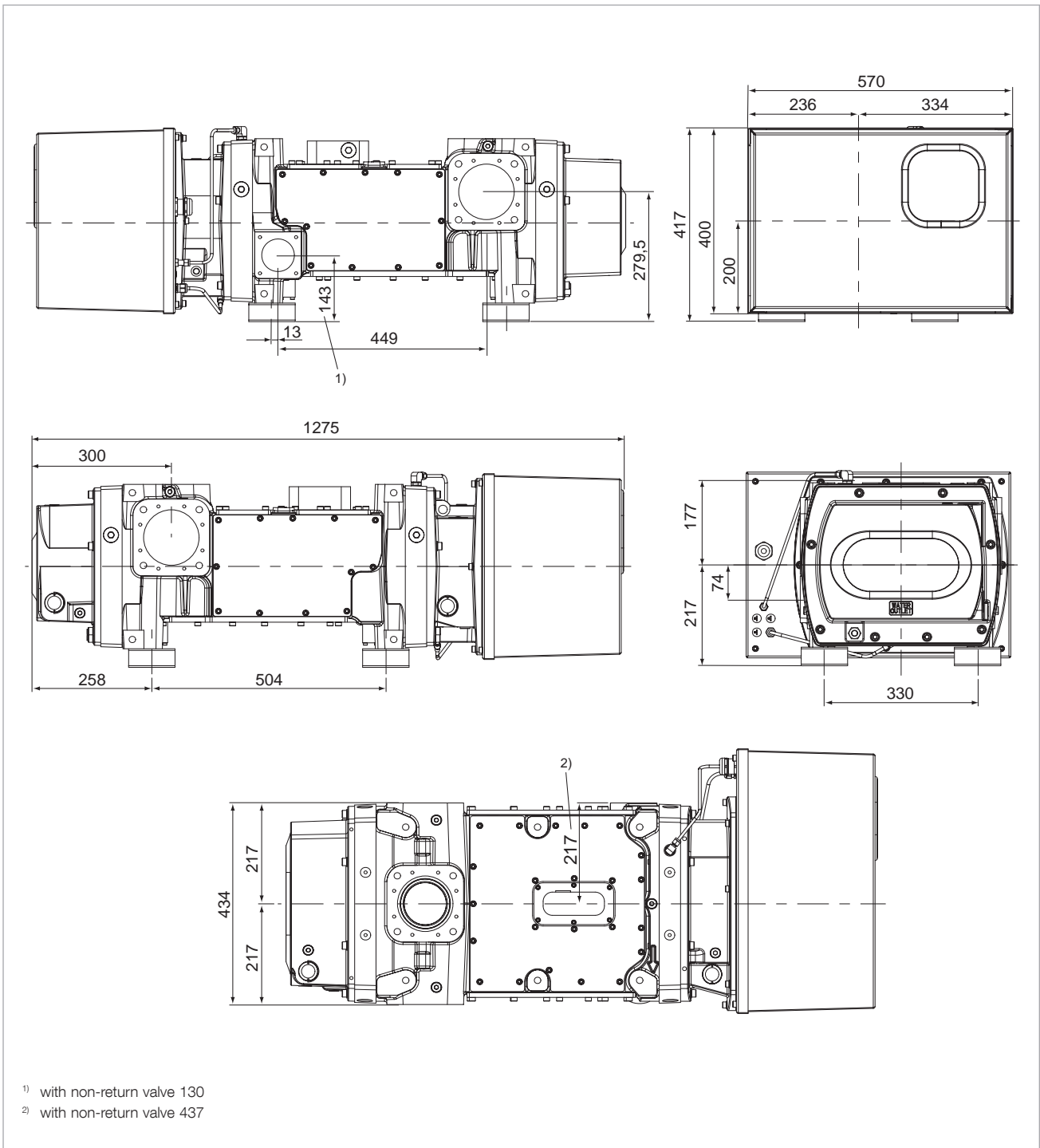

Dimensional drawing for the DRYVAC DV 650 and DV 800, all dimensions in mm

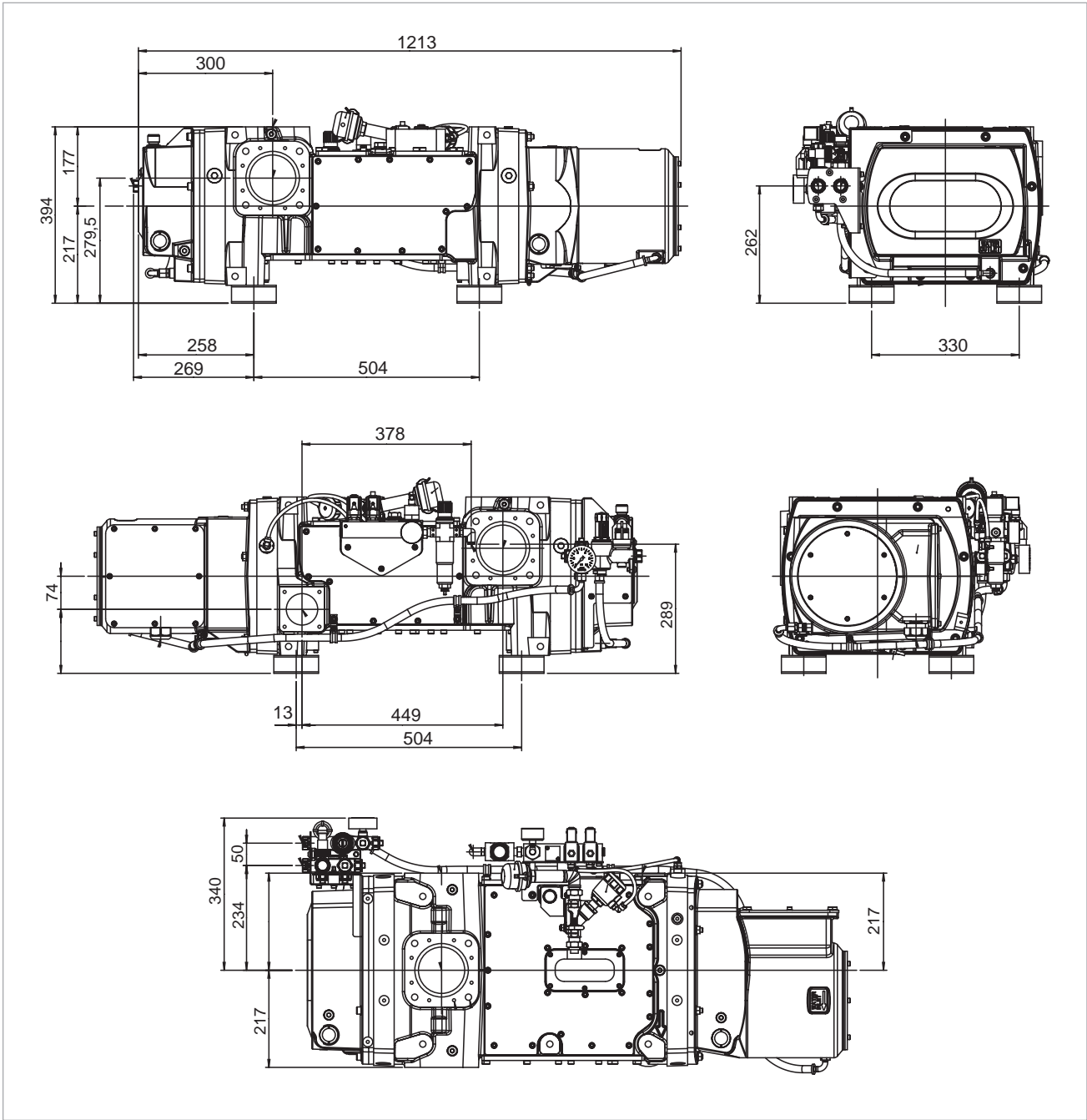

Dimensional drawing for the DRYVAC DV 650-r, all dimensions in mm

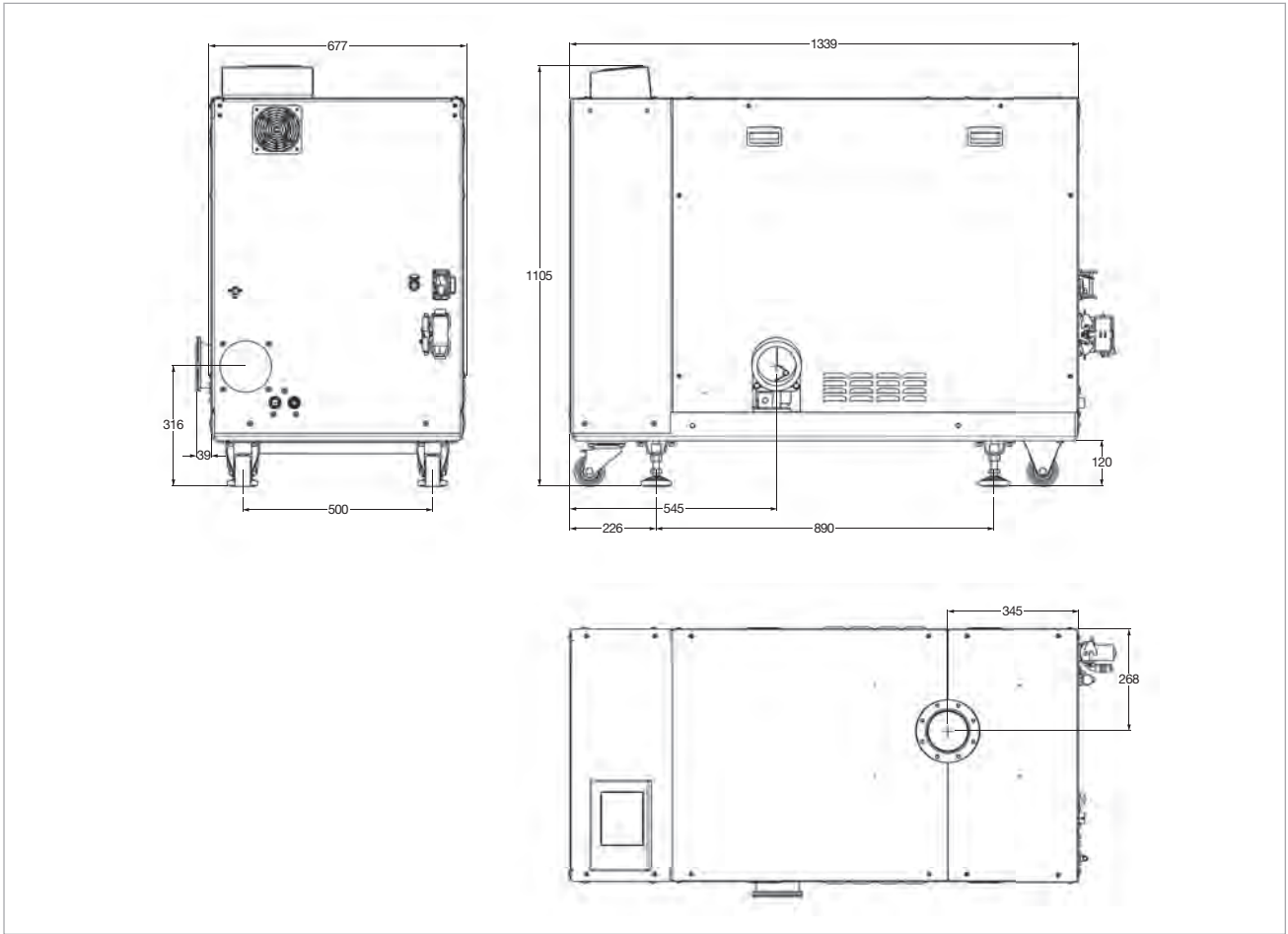

Dimensional drawing for the DRYVAC DV 1200 S-i, all dimensions in mm

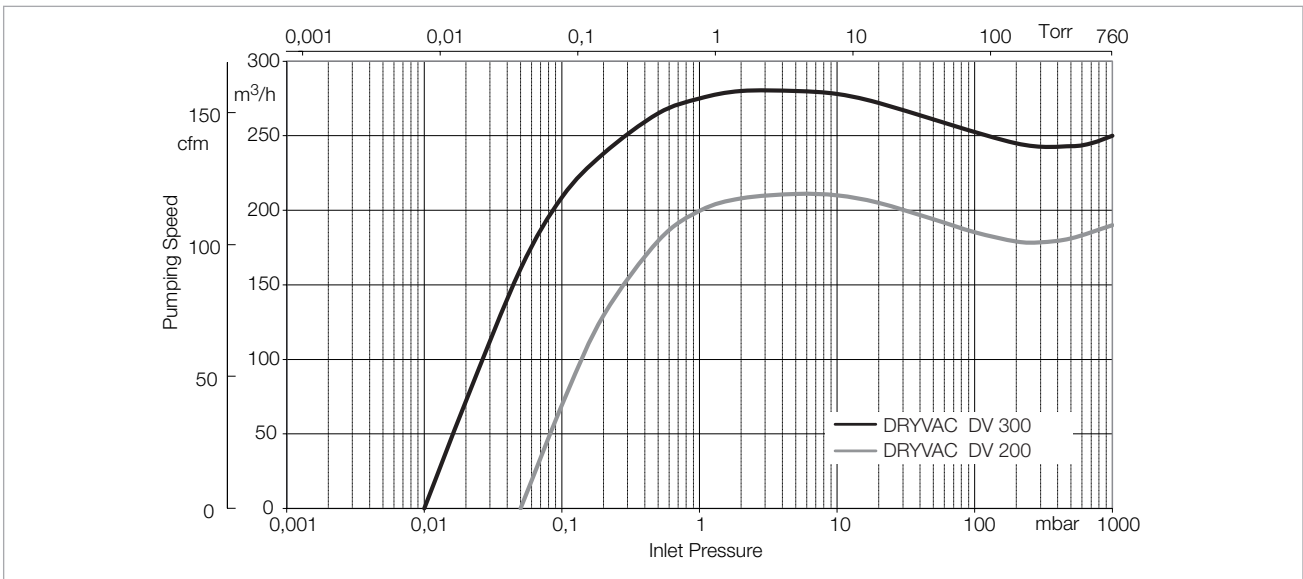

Pumping speed curves of the DRYVAC DV 200 and DV 300

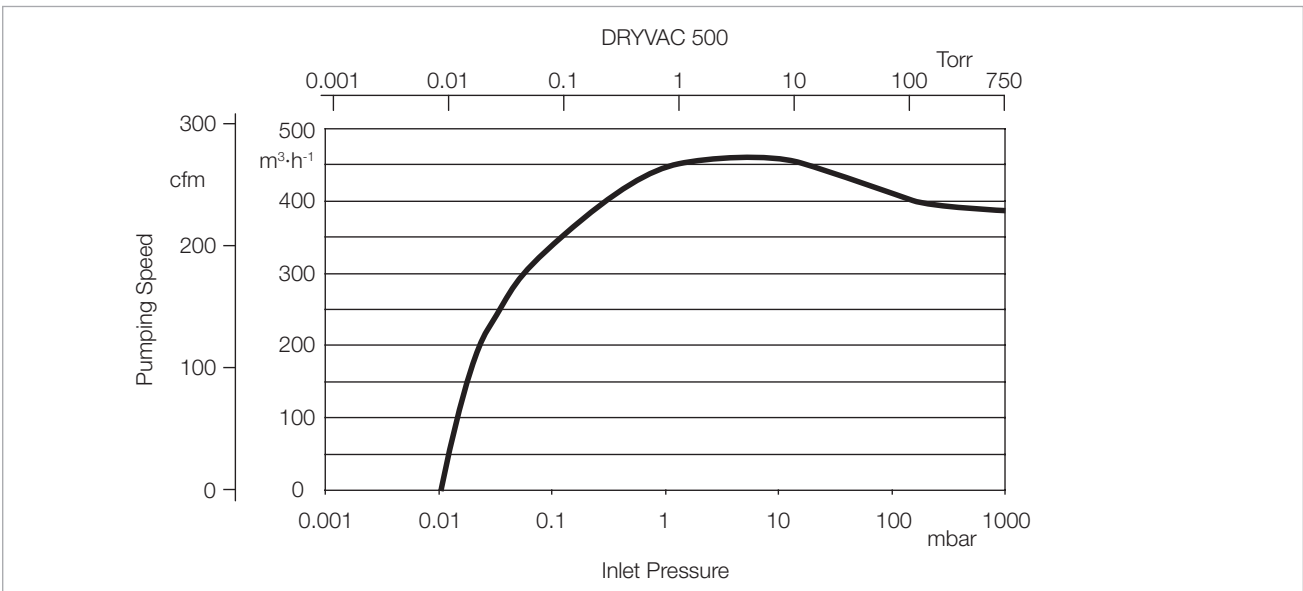

Pumping speed curve of the DRYVAC DV 500

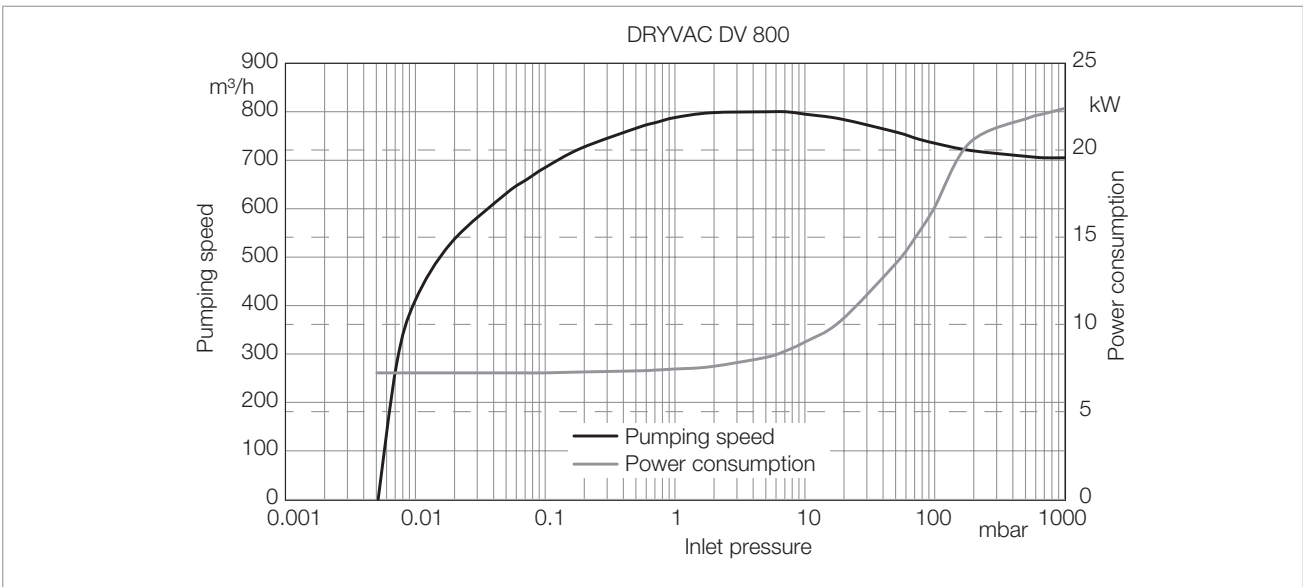

Pumping speed curve of the DRYVAC DV 800

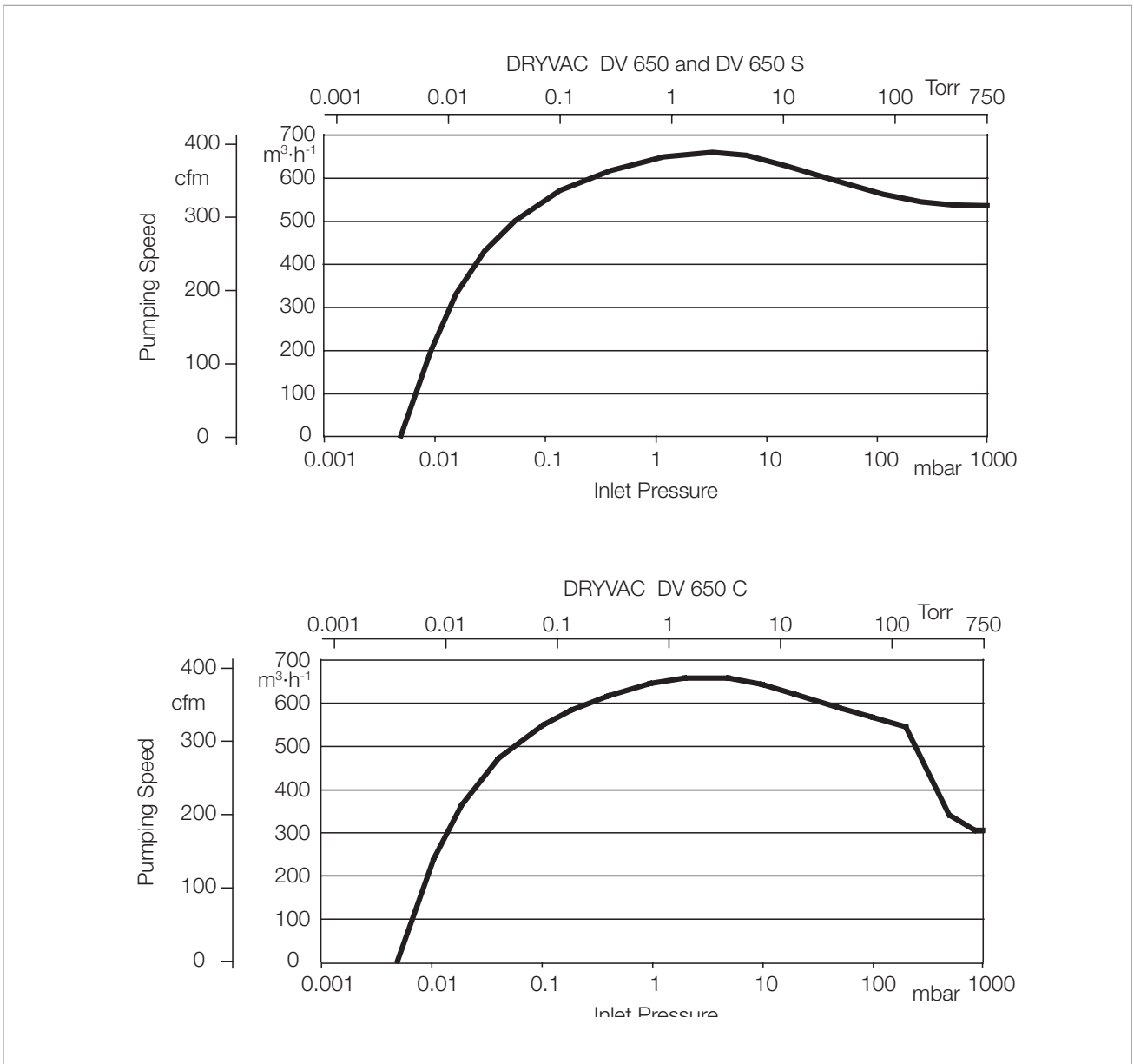

Pumping speed curves of the DRYVAC DV 650 (S) and DRYVAC DV 650 C

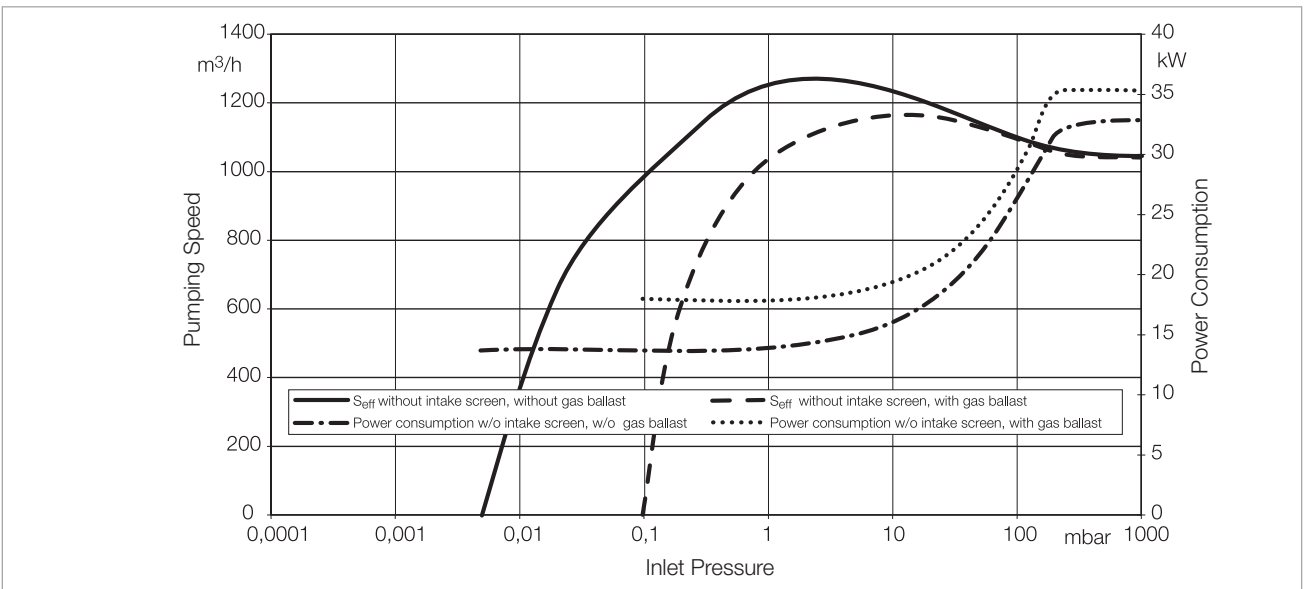

Pumping speed curves of the DRYVAC DV 1200 and DV 1200 S-i

## Technical Data

## DRYVAC DV

		200	300	500
Max. effective pumping speed	m <sup>3</sup> /h (cfm)	210 (123.6)	280 (164.8)	460 (270.8)
Ultimate pressure	mbar (Torr)	< 0.05 (< 0.038)	< 0.01 (< 0.0075)	< 0.01 (< 0.0075)
Permissible ambient temperature	°C (°F)	+5 to +50 (+41 to +122)		
Water vapour tolerance with > 20 slm purge gas or gas ballas	mbar (Torr)	50 (37.5)		
Water vapour capacity	kg/h	5		
Noise level at ultimate pressure with silencer with rigid exhaust line	dB(A) dB(A)	65 65		
Power consumption at ultimate pressure	kW	4.1	4.5	4.4
Lubricant filling		LV 210 synthetic Oil		
Cooling		water		
Electrical connection	V	380-460 or 200-240 ±10 %, 50/60 Hz	380-460 or 200-240 ±10 %, 50/60 Hz	200-240 / 380-480, 50/60 Hz
Phases		3-ph.		
Nominal power	kW	7.5	7.5	11.0
Nominal current at 400 V	A	13.8	13.8	20.9
Intake connection	DN	63 ISO-K		
Exhaust side connection	DN	40 ISO-KF		
Protection class EN 60529	IP	54		
Weight	kg (lbs)	370 (815.7)	370 (815.7)	490 (1080.3)
Dimensions (W x D x H)	mm (in.)	1115 x 612 x 478 (43.9 x 24.1 x 18.8)	1115 x 612 x 478 (43.9 x 24.1 x 18.8)	1225 x 612 x 478 (48.2 x 24.1 x 18.8)
Cooling water connection Threads, female	G	1/2		
Cooling water temperature	°C (°F)	5 to 35 (41 to 95)		
Cooling water throughput, nominal (US gallon/min)	l/min	8 (2.11)		
Purge gas connection (plugged connection)		D10		

**Ordering Information**
**DRYVAC DV**

	<b>200</b>	<b>300</b>	<b>500</b>
	<b>Part No.</b>	<b>Part No.</b>	<b>Part No.</b>
DRYVAC 200 V 400 V	<b>112020V19</b> <b>112020V15</b>	<b>112030V19</b> <b>112030V15</b>	<b>112050V19</b> <b>112050V15</b>
DRYVAC LVO 410 (PFPE) 200 V 400 V	<b>112020V29</b> <b>112020V25</b>	- -	- -
DRYVAC ATEX, 400 V	-	<b>112030V11</b>	-
<b>Accessories</b>			
Profibus module for DRYVAC DV / DV-r	<b>155212V</b>	<b>155212V</b>	<b>In preparation</b>
ProfiNet module for DRYVAC DV / DV-r	<b>112005A35</b>	<b>112005A35</b>	<b>In preparation</b>
EtherCAT module for DRYVAC DV / DV-r	<b>112005A36</b>	<b>112005A36</b>	<b>In preparation</b>
Relay module (digital output) for DRYVAC DV / DV-r	<b>112005A01</b>	<b>112005A01</b>	<b>In preparation</b>
Ethernet module (Dual port) for DRYVAC DV / DV-r	<b>112005A02</b>	<b>112005A02</b>	<b>In preparation</b>
RS485/USB cable for interface X104, 1.8 m	<b>161820USB</b>		
Adapter DRYVAC for			
RUVAC WH 501 / WH 700	<b>112004A03</b>	<b>112004A03</b>	<b>112003A03</b>
RUVAC Wx(U) 1001	<b>112004A04</b>	<b>112004A04</b>	<b>112003A04</b>
RUVAC Wx(U) 2001	<b>112004A05</b>	<b>112004A05</b>	<b>112003A05</b>
RUVAC WH(U) 2500	<b>112004A07</b>	<b>112004A07</b>	<b>112003A07</b>
RUVAC WH(U) 4400 / 7000	-	-	<b>112003A10</b>
Non-return valve DRYVAC, DN 40 KF <sup>1)</sup>			
DN 40 KF <sup>1)</sup>	<b>115005A01</b>	<b>115005A01</b>	-
Spring loaded, all orientations	<b>112004A14</b>	<b>112004A14</b>	<b>112003A14</b>
Elbow 90° DN 40 KF, stainless steel	<b>88464</b>		
Silencer			
DN 40 KF	<b>115005A21</b>	<b>115005A21</b>	-
DN 63 ISO-K	-	-	<b>119002</b>
Flush kit, electro-magnetic valve	<b>112004A33</b>	<b>112004A33</b>	-
Inlet purge, electro-magnetic valve	<b>112004A34</b>	<b>112004A34</b>	-
Synthetic Oil, ester oil, LEYBONOL LVO 210, 5 litres	<b>L21005</b>		

<sup>1)</sup> must only be installed vertically

## Technical Data

## DRYVAC DV

		650	800	1200-i	1200
Max. effective pumping speed	m <sup>3</sup> /h (cfm)	650 (383)	800 (471)	1250 (736)	1250 (736)
Ultimate pressure	mbar (Torr)	5 x 10 <sup>-3</sup> (4 x 10 <sup>-3</sup> )			
Permissible ambient temperature	°C (°F)	+5 to +50 (+41 to +122)			
Water vapour tolerance with > 20 slm purge gas or gas ballast	mbar (Torr)	60 (45)	60 (45)	- -	- -
with > 40 slm purge gas or gas ballast	mbar (Torr)	- -	- -	60 (45)	60 (45)
Water vapour capacity	kg/h	25	30	50	50
Noise level at ultimate pressure with silencer	dB(A)	67			
with rigid exhaust line	dB(A)	65			
Power consumption at ultimate pressure	kW	6.6	7	14	14
Cooling		water	water	water/air	water
Electrical connection		380 – 460 V, 50/60 Hz			
Phases		3-ph.			
Nominal power at 400 V	kW	15	22	30	30
Nominal current at 400 V	A	31	38	62	62
Intake connection	DN	100 ISO-K PN6 (1x at the top, 2x at the side)	100 ISO-K PN6 (1x at the top, 2x at the side)	100 ISO-K	100 ISO-K
Exhaust side connection	DN	63 ISO-K	63 ISO-K	100 ISO-K	100 ISO-K
Protection class EN 60529	IP	54	54	20	54
Weight	kg (lbs)	589 (1280)	589 (1280)	1400 (3091)	1400 (3091)
Dimensions (W x D x H)	mm (in.)	1280 x 570 x 420 (50.4 x 22.4 x 16.5)	1280 x 570 x 420 (50.4 x 22.4 x 16.5)	1339 x 677 x 1105 (53.9 x 26.7 x 43.5)	1339 x 677 x 1105 (53.9 x 26.7 x 43.5)
Cooling water connection Threads, female	G	1/2			
Cooling water temperature with gear oil LEYBONOL LVO 210	°C (°F)	5 to 35 (41 to 95)			
with gear oil LEYBONOL LVO 410	°C (°F)	5 to 25 (41 to 77)			
Cooling water throughput, nominal	l/min (US gallon/min)	7.5* (2.0)*	10.0 (3.0)	15.0 (4.0)	15.0 (4.0)
Purge gas connection (plugged connection)		D10			

\* DRYVAC 650 LVO 410 (PFPE) 10.0 l/min (3.0 US gallon/min)

**Ordering Information**
**DRYVAC DV**

	<b>650</b>	<b>800</b>	<b>1200-i</b>	<b>1200</b>
	<b>Part No.</b>	<b>Part No.</b>	<b>Part No.</b>	<b>Part No.</b>
DRYVAC LVO 210 (Industrial) Double purge and air- gasballast				
200 V	<b>112065V19-1</b>	-	-	-
400 V	<b>112065V15-1</b>	<b>112080V15-1</b>	-	<b>112120V17-1</b>
400 V, with Energy Saver	<b>112065V16-1</b>	-	-	-
DRYVAC LVO 210 (Industrial) Triple purge				
400 V	<b>112065V17-1</b>	<b>112080V17-1</b>	<b>112120V50-1</b>	-
400 V, with Energy Saver	<b>112065V18-1</b>	-	-	-
DRYVAC LVO 210 (Industrial) Load lock, 400 V	<b>112065V09-1</b>	-	-	-
DRYVAC LVO 210 ATEX, 400 V	<b>112065V11-1</b>	-	-	<b>112120V11-1</b>
DRYVAC LVO 410 (PFPE) S Single purge				
200 V	-	-	-	-
400 V	<b>112065V20-1</b>	-	<b>112120V40-1</b>	-
DRYVAC LVO 410 (PFPE) C Triple purge, 400 V	<b>112065V30-1</b>	-	-	-
<b>Accessories</b>				
DRYVAC Energy Safer (only for LVO 210)	<b>112005A60</b>	<b>112005A60</b>	-	-
Glycol Air-Cooling-System FLKS-4S	<b>112005A45</b>	<b>112005A45</b>	-	-
Kit Fitting Hoses for Glycol Air-Cooling-System	<b>112005A47</b>	<b>112005A47</b>	-	-
Outlet Flange DN 63 ISO-K x 80 mm	<b>112005A62</b>	<b>112005A62</b>	-	-
Profibus module for DRYVAC DV / DV-r	<b>155212V</b>	<b>In preparation</b>	-	-
ProfiNet module for DRYVAC DV / DV-r	<b>112005A35</b>	<b>In preparation</b>	-	-
EtherCAT module for DRYVAC DV / DV-r	<b>112005A36</b>	<b>In preparation</b>	-	-
Relay module (digital output) for DRYVAC DV	<b>112005A01</b>	<b>In preparation</b>	-	-
Ethernet module (Dual port) for DRYVAC DV	<b>112005A02</b>	<b>In preparation</b>	-	-
LEYASSIST Windows Software <sup>2)</sup>		<b>230439V01</b>		
RS232 adapter for FC DRYVAC RUVAC WH		<b>155224V</b>		
Adapter USB – RS232		<b>800110V0103</b>		
Interface kit 24 Volt I/O for DRYVAC DV / DV-i		<b>112005A22</b>		
Adapter DRYVAC for DV 650/800				
RUVAC WH 700		<b>112005A03</b>		
RUVAC WS(U) 1001		<b>112005A04</b>		
RUVAC WS(U) 2001		<b>112005A05</b>		
RUVAC WH(U) 2500		<b>112005A07</b>		
RUVAC WH(U) 4400/7000		<b>112005A10</b>		
Cooling water unit				
DRYVAC 650/800		<b>112005A12</b>		
DRYVAC 650-r/800		<b>112005A13</b>		
Non-return valve DRYVAC, DN 63 ISO-K <sup>1)</sup>		<b>112005A15</b>		
Disc-check valve, spring loaded, DN 63 ISO-K		<b>112005A14</b>		
Gas ballast kit DRYVAC, 24 V electro-pneumatic		<b>112005A17</b>		
Silencer				
DN 63 ISO-K for DV 650/800 and SP 250		<b>119002</b>		
DN 100 ISO-K for DV 1200 and SP 630		<b>119001</b>		
Serviceable silencer				
DN 63 ISO-K for DV 650/800 and SP 250		<b>119003V</b>		
DN 100 ISO-K for DV 1200 and SP 630		<b>119004V</b>		
External display (not for 1200-i)		<b>155213V</b>		
Harting plug DRYVAC S-i/C-i		<b>112005A20</b>		
Set of nozzles for DRYVAC purge gas		<b>112005A30</b>		
Permanent inlet purge kit		<b>112005A32</b>		

<sup>1)</sup> Already integrated in all -i versions

<sup>2)</sup> Operating, configuration and analysis software for DRYVAC and other Leybold products



# General

## Applications for SCREWLINE Pumps

Dry Compressing  
Vacuum Pumps

Dry Compressing Scroll Vacuum Pumps	SCREWLINE SP 250 (ATEX)	SCREWLINE SP 630 F (ATEX)
<b>Applications</b>		
Food processing	■	■
Vacuum coating	■	■
Lamination	■	■
Loadlock chambers	■	■
Mechanical engineering	■	■
Automotive industry	■	■
Metallurgy/Furnaces	■	■
Crystal pulling	■	■
Degassing	■	■
Electrical engineering	■	■
Energy technology	■	■
Welding technology	■	■
Lamps/Tubes manufacture	■	■
Cooling and air conditioning	■	■
Chemistry/Pharmaceuticals	■	■
Chemical research laboratories	■	■
Vacuum drying	■	■
Freeze drying systems	■	■
Environmental engineering	■	■
Packaging	■	■
Medical technology	■	■
Analytical engineering	■	■
Research and development	■	■
Space simulation	■	■
Backing pump for HV-Systems	■	■

# Products

## Screw Vacuum Pumps

### SCREWLINE SP 250 to SCREWLINE SP 630 (F)



Screw Vacuum Pump SCREWLINE SP 630

The Screw Vacuum Pumps SCREWLINE SP were developed in view of the special requirements of industrial applications. The innovative design allows these pumps to be used whenever reliable, compact and low maintenance vacuum solutions are required.

#### Principle of Operation

Screw Vacuum Pumps are dry compressing backing pumps, the operation of which is based on the screw principle. The pumping chamber of the pump is formed by two synchronised positive displacement rotors and the housing enclosing these. Since the rotors rotate in opposite directions, the chambers move steadily from the intake to the exhaust side of the pumps thereby resulting in a smooth pumping action (see figure below). Since with a single Screw Vacuum Pump rotor pair a multistage compression process is implemented, the component count in the pumping path is very low. In this way maintenance and servicing work is much simplified.

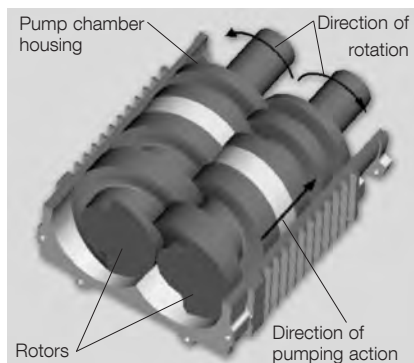

Principle of operation of the SCREWLINE Line

#### Properties

The direct pumping path without multiple deflections for the medium make the Screw Vacuum Pumps highly insensitive to foreign materials. This ensures a high uptime in industrial processes.

The two non-contacting shaft-seals are practically wear-free, which allows for very long maintenance intervals. Shaft seal purge is usually required in industrial applications. SCREWLINE SP pumps are equipped with a purge gas supply unit.

Because of the cantilevered bearing arrangement for the Screw Vacuum Pump rotors, a potential source of failure (i.e. a bearing on the intake side) is entirely eliminated. On the one hand, no lubricants from the bearings can enter into the vacuum process, and the other hand also an impairment of the bearing by aggressive process media can be excluded.

A further benefit of the cantilevered bearing arrangement is the easy

accessibility of the pump chamber. This innovative design feature allows the removal of the pump housing without time-consuming and costly disassembly of the bearings. Thus on-site cleaning of all surfaces in contact with the medium is possible. In particular, if the processes involved considerable amounts of contaminants this is a significant advantage which ensures a long uptime.

The low exhaust temperature is an important advantage of the Screw Vacuum Pumps. Owing to the design of the screw rotors, a temperature of maximum 100 °C (212 °F) is attained inside the pump. Thus deposits of many substances are avoided which react at high temperatures. This makes the pump unique and many customers, above all from the field of coating, value this highly. Should deposits form in spite of this, then the easy to disassemble housing facilitates rapid cleaning.

Besides the integrated oil cooling arrangement for the rotors, the Screw Vacuum Pumps are air-cooled from the outside. Here rotor and housings are thermally linked via the oil cooler. Thus, Screw Vacuum Pumps adapt themselves ideally to the ambient conditions under changing operating situations.



Oil/water cooling unit SP 630 F

A water-cooled version is offered as Screw Vacuum Pumps SP 630 F. This product version is intended for operation in air-conditioned rooms.

The Screw Pumps portfolio is completed through ATEX-certified variants.

Moreover, the Screw Vacuum Pumps portfolio also includes pump versions suited for pumping pure oxygen (O<sub>2</sub>).

## Maintenance and Monitoring

During the development of the Screw Vacuum Pumps, special emphasis was placed on a particularly simple maintenance concept. This has been implemented through the cantilevered bearing arrangement, with all maintenance components and controls having been located on the so-called service side for easy accessibility. Thus, the space requirement which needs to be taken into account during planning has been optimized. The lower space requirement gives the user more flexibility during installation of the pump.

The monitoring system SP-GUARD was developed especially for constant real-time monitoring of the operational status of the Screw Vacuum Pumps. The operating parameters are con-

stantly acquired and processed. This enables the user to introduce preventive actions early enough so as to ensure trouble-free operation of his Screw Vacuum Pumps. The key current operating parameters can be read off from a local display. Moreover, connection to a PLC and remote monitoring is possible. Maintenance of the Screw Vacuum Pumps will generally be limited to a regular visual inspection of the pump and the annual change of gear oil and oil filter. The oil fill ports as well as the filters are readily accessible and can be easily exchanged.

With the aid of a flushing kit (optional) it is possible to clean the pump chamber, while the pump is operating without process. Deposits due to the process can thus be removed effectively and quickly without the need of having to disassemble the housing.

Also, cleaning of the air/oil heat exchanger can be done simply on-site by blowing out the heat exchanger with compressed air.

## Accessories

Screw Vacuum Pumps offer to the user a high degree of flexibility. Inlet and exhaust connections are made through universal flanges, respectively clamped flanges, permit simple integration within the system. Through the accessories which are available, the pump can be optimally adapted to the individual requirements of differing applications.

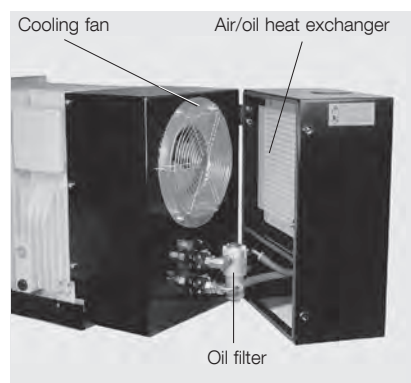

Oil/water cooling unit SP 630

## Advantages to the User

- Utmost reliability
- Protection of the pump through monitoring vital parameters by means of the SP-GUARD
- Minimum downtimes owing to rapid cleaning of the pump chamber (in less than one hour)
- Avoidance of deposits through low internal temperatures
- Minimum operating costs
- The only directly air cooled screw vacuum pump on the market. No need for cooling water
- No oil in the pump chamber. Thus no need for disposing of contaminated oil
- Gear oil change only every two years
- Utmost flexibility
- Direct adaptation of RUVAC pumps for increased pumping speed up to approximately 7000 m<sup>3</sup>/h
- Multi-flange for all commonly used pipe connections
- Flushing kit for constant cleaning of the pump chamber
- Silencing hoods for a further reduction of noise emissions

## Typical Applications

- Industrial furnaces
- Coating technology
- Load lock chambers
- Metallurgical systems
- Food processing
- Drying processes
- Degassing
- Research and development
- Lamps and tubes manufacture
- Automotive industry
- Packaging industry
- Space simulation
- Electrical engineering
- Energy research

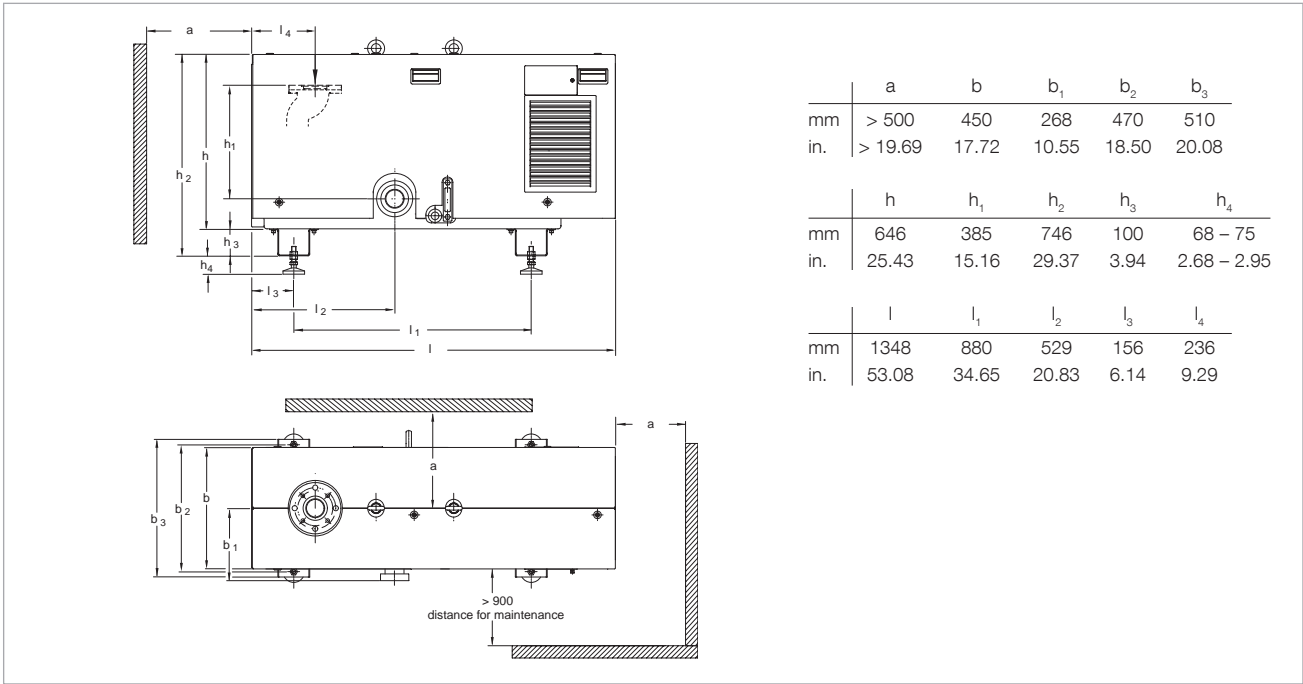

Dimensional drawing for the SCREWLINE SP 250

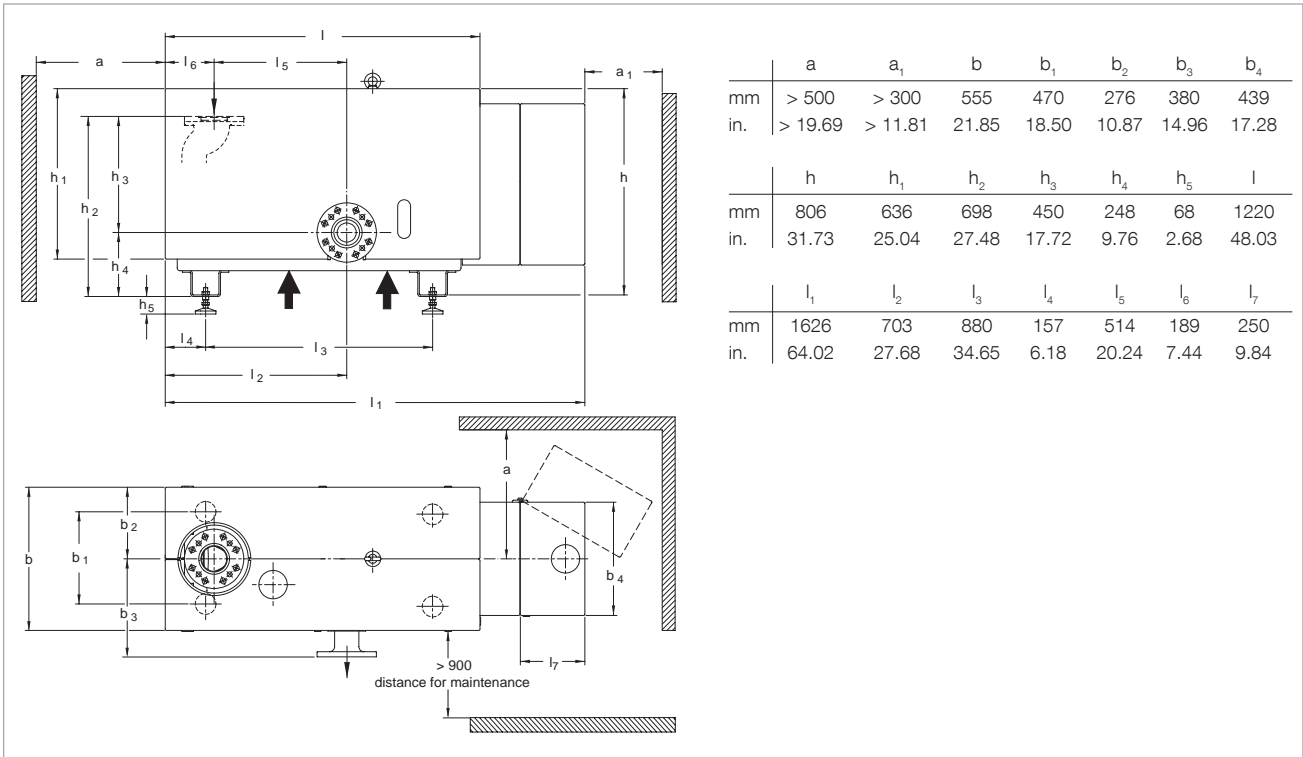

Dimensional drawing for the SCREWLINE SP 630

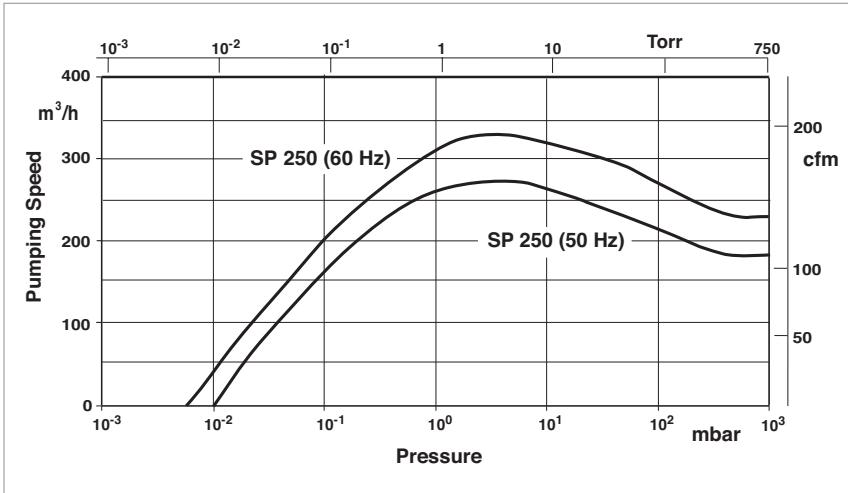

Effective pumping speed of the SCREWLINE SP 250 for air, without gas ballast (50/60 Hz)

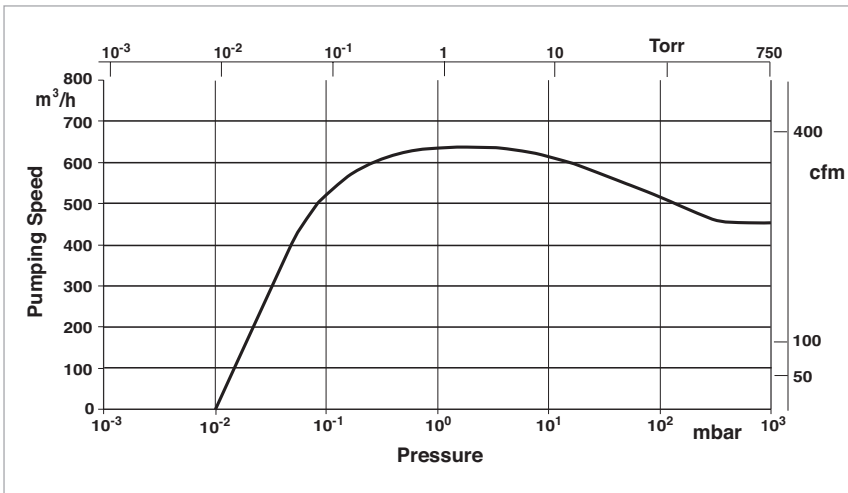

Effective pumping speed of the SCREWLINE SP 630 for air, without gas ballast

## Technical Data

## SCREWLINE SP 250

		50 Hz	60 Hz
Effective pumping speed	m <sup>3</sup> /h (cfm)	270 (157)	330 (194)
Ultimate pressure, total	mbar (Torr)	≤ 0.01 (≤ 0.0075)	≤ 0.005 (≤ 0.0038)
Permissible intake pressure, max.	mbar (Torr)	1030 (773)	
Maximum exhaust pressure with reference to the ambient pressure		$p_{ex} = p_{amb}$ + 200 mbar (150 Torr) - 50 mbar (37 Torr)	
Permissible ambient temperature	°C (°F)	+10 to +40 (+50 to +104)	
Water vapour tolerance (with gas ballast)	mbar (Torr)	60 (45)	75 (56)
Water vapour capacity (with gas ballast)	g/h (gal/h)	10 (2.7)	18 (4.9)
Installation location		up to 3000 metres (9.800 feet) (above sea level)	
Cooling		Air	
Power supply at operating voltage	$\Delta\Delta$ $\Delta$	32.0 A / 200 V (cos phi 0.88) 16.0 A / 400 V (cos phi 0.88)	31.5 A / 210 V (cos phi 0.88) 15.5 A / 460 V (cos phi 0.88)
Nominal power	kW (HP)	7.3 (9.9)	9.2 (12.5)
Power consumption at ultimate pressure	kW (HP)	5.9 (8.0) at 3-ph. 200 V / 400 V	7.2 (9.8) at 3-ph. 200 V / 400 V
Energy efficiency class		IE 2	
Motor rotational speed	rpm	2910	3490
Type of protection	IP	55	
Thermal protection class		F	
Lubricant filling (LVO 210)	l	7	
Intake flange, standard Clamping flange Bolt flange Bolt flange		ISO 1609-1986 (E)-63 (DN 63 ISO-K) <sup>1)</sup> ASME B 16.5 NPS 3 class 150 EN 1092-2-PN 6 - DN 65	
Exhaust flange, standard Clamping flange		ISO 1609-1986 (E)-63 (DN 63 ISO-K)	
Exhaust flange, optional Clamping flange Bolt flange Bolt flange Bolt flange		ISO 1609-1986 (E)-63 (DN 63 ISO-K) <sup>1)</sup> ASME B 16.5 NPS 3 class 150 EN 1092-2-PN 16 - DN 65 EN 1092-2-PN 6 - DN 65	
Materials (components in contact with the gas)		Aluminum, aluminum anodic oxidised, C steel, CrNi steel, grey cast-iron, FPM (FKM) (Viton)	
Weight, approx.	kg (lbs)	450 (992)	
Dimensions (W x D x H)	mm (in.)	1350 x 530 x 880 (53.1 x 20.9 x 34.6)	
Noise level <sup>2)</sup>	dB(A)	≤ 68	≤ 72

<sup>1)</sup> This flange is required when ISO-K flanges are to be connected (Part No. 267 47)

<sup>2)</sup> With connected exhaust gas line at ultimate pressure

## Ordering Information

## SCREWLINE SP 250

	Standard	ATEX	O <sub>2</sub>
	Part No.	Part No.	Part No.
Screw Vacuum Pump SP 250 (50/60 Hz) with purge gas unit and manual gas ballast	<b>115 001</b> <sup>1)</sup>	-	-
with purge gas unit and manual gas ballast, with castors	<b>115 006</b> <sup>1)</sup>	-	-
with purge gas unit and electromagnetic gas ballast, II 3-G Ex h IIC 160 °C Gc II 3-D Ex h IIIB T160 °C Dc 10°C<Ta<40°C	-	<b>115 003</b> <sup>1, 2)</sup>	-
with purge gas unit and electromagnetic gas ballast, with purge vent kit and FFPM gaskets, II 2/3G Ex h IIC 160 °C Gb / Ex h nA IIC 160 °C Gc II 3/3D Ex h IIIB T160 °C Dc / Ex h tc IIIB T160 °C Dc 10°C<Ta<40°C	-	<b>115 012V11</b> <sup>1)</sup>	-
with purge gas unit and electromagnetic gas ballast	-	-	<b>115 019</b> <sup>1), 3)</sup>
<b>Accessories</b>			
Exhaust silencer	<b>119 002</b>	<b>119 002</b>	<b>119 002</b>
Serviceable silencer	<b>119 003V</b>	<b>119 003V</b>	<b>119 003V</b>
Exhaust non-return valve (DN 65 PN 6)	<b>119 011</b>	-	-
Solenoid gas ballast kit, 24 V <sup>4)</sup>	<b>119 054V</b>	-	-
Adaptor for RUVAC 501/1001	<b>119 022</b>	<b>119 022</b>	<b>119 022</b>
Purge gas retrofit kit	<b>119 031</b>	-	-
Inlet filter adapter DN 63 ISO-K	<b>119 019</b>	<b>119 019</b>	-
Dust filter	<b>951 68</b>	-	-
Purge vent kit	<b>119 061V</b>	<b>119 061V</b>	<b>119 061V</b>
Flushing kit	<b>119 015V02</b>	<b>119 015V02</b>	<b>119 015V02</b>
Oil change kit	<b>EK 110 000 820</b>	<b>EK 110 000 820</b>	<b>EK 110 000 820</b>
Screw inspection kit	<b>EK 110 000 821</b>	<b>EK 110 000 821</b> <sup>5)</sup>	<b>EK 110 000 821</b>
Purge gas connection servicing kit	<b>EK 110 000 834</b>	<b>EK 110 000 834</b>	<b>EK 110 000 834</b>
Filter for gas ballast	<b>E 110 000 980</b>	<b>E 110 000 980</b>	<b>E 110 000 980</b>
Filter for purge gas valve unit	<b>E 110 000 850</b>	<b>E 110 000 850</b>	<b>E 110 000 850</b>
Absorbing felt	<b>E 110 002 435</b>	<b>E 110 002 435</b>	<b>E 110 002 435</b>
Silencer service kit	<b>EK 500 003 476</b>	<b>EK 500 003 476</b>	<b>EK 500 003 476</b>
Seal kit non-return valve SP 250	<b>EK 110 000 828</b>	<b>EK 110 000 828</b>	<b>EK 110 000 828</b>
Seal kit RUVAC adaptor SP 250	<b>EK 110 000 835</b>	<b>EK 110 000 835</b>	<b>EK 110 000 835</b>
Vibration element RUVAC adaptor SP 250	<b>ES 110 000 2677</b>	<b>ES 110 000 2677</b>	<b>ES 110 000 2677</b>

<sup>1)</sup> All pumps are equipped as standard with an SP-GUARD

<sup>2)</sup> Only ATEX Category 3i (Directive 2014/34/EU)

<sup>3)</sup> T4 with max.  $p_{ex} = p_{amb} + 200 \text{ mbar}$   
- 50 mbar

<sup>4)</sup> This accessory item can only be used beginning with SN (serial number) 31000530865

<sup>5)</sup> Only for Part No. 115 003

U)

For all enquiries and orders relating to category 1 and 2 ATEX products please exclusively use our ATEX questionnaire. You can find this questionnaire at the end of the full-line catalog together with the fax forms or on the Internet under "www.leybold.com" under Media > Downloads > Download Documents > General Documents.

## Technical Data

## SCREWLINE SP 630

50 Hz

60 Hz

		50 Hz	60 Hz
Effective pumping speed	m <sup>3</sup> /h (cfm)	630 (371)	
Ultimate pressure, total	mbar (Torr)	≤ 0.01 (≤ 0.0075)	
Permissible intake pressure, max.	mbar (Torr)	1030 (773)	
Maximum exhaust pressure with reference to the ambient pressure		$p_{ex} = p_{amb}$ + 200 mbar (150 Torr) - 50 mbar ( 37 Torr)	
Permissible ambient temperature	°C (°F)	+10 to +40 (+50 to +104)	
Water vapour tolerance (with gas ballast)	mbar (Torr)	40 (30)	
Water vapour capacity (with gas ballast)	g/h (gal/h)	14 (3.7)	
Installation location		up to 3000 metres (9.800 feet) (above sea level)	
Cooling		Air	
Power supply	ΔΔ Δ Y <sup>1)</sup>	56 A / 200 V 28 A / 400 V 16 A / 690 V	52 A / 210 V 24 A / 460 V -
cos φ		0.89	0.90
Nominal power	kW (HP)	15 (20)	
Power consumption at ultimate pressure	kW (HP)	< 11 (< 15)	
Energy efficiency class		IE 2	
Motor rotational speed	rpm	2930	3530
Type of protection	IP	55	
Thermal protection class		F	
Lubricant filling (LVO 210)	l	15	
Intake flange and exhaust flange compatible with bolt flanges		EN 1092-2 - PN 6 – DN 100 EN 1092-2 - PN 16 – DN 100 ISO 1609-1986 (E)-100 (DN 100 ISO-K) <sup>2)</sup> ASME B 16.5 NPS 4 class 150	
Materials (components in contact with the gas)		Aluminum, aluminum anodic oxidised, C steel, CrNi steel, grey cast-iron, FPM (FKM) (Viton)	
Weight, approx.	kg (lbs)	530 (1166)	
Dimensions (W x D x H)	mm (in.)	1630 x 660 x 880 (64 x 26 x 35)	
Noise level <sup>3)</sup>	dB(A)	≤ 72	

<sup>1)</sup> 690 V upon request

<sup>2)</sup> This flange is required when ISO-K flanges are to be connected (Part No. 267 50)

<sup>3)</sup> With connected exhaust gas line at ultimate pressure

## Additional Technical Data

## SCREWLINE SP 630 F

50 Hz

60 Hz

		50 Hz	60 Hz
Cooling	m <sup>3</sup> /h	Water	
Water connection	G	1/2" ISO 228-1	
Water temperature	°C (°F)	+5 to +35 (+41 to +95)	
Minimum water feed pressure	bar (psi, gauge)	2 (15)	
Nominal flow at a water feed temperature of 25° C (77 °F)	l/min (gal/min)	12 (3)	

<sup>1)</sup> With connected exhaust gas line at ultimate pressure

**Ordering Information**
**SCREWLINE SP 630 Standard / SP 630 F Standard**

	<b>50 Hz</b>	<b>60 Hz</b>
	<b>Part No.</b>	<b>Part No.</b>
Screw Vacuum Pump SP 630 air cooled, with purge gas unit and manual gas ballast	<b>117 007</b>	<b>117 008</b>
Screw Vacuum Pump SP 630 F water cooled, with purge gas unit and electromagnetic gas ballast, with adapter for RUVAC 2001	<b>117 105</b>	<b>117 106</b>
water cooled, with purge gas unit and manual gas ballast	<b>117 113</b>	<b>117 114</b>
with purge gas unit and manual gas ballast, with phase watchdog	—	<b>117 114V02</b>

All pumps are equipped as standard with an SP-GUARD

**Ordering Information**
**SCREWLINE SP 630 ATEX / SP 630 F ATEX**

	<b>50 Hz</b>	<b>60 Hz</b>
	<b>Part No.</b>	<b>Part No.</b>
Screw Vacuum Pump SP 630 air cooled, with purge gas unit and manual gas ballast, II 3/-G Ex h IIC 160 °C Gc II 3/-D Ex h IIIB T160 °C Dc 10°C<Ta<40°C	<b>117 017</b>	<b>117 018</b>
water cooled, with purge gas unit and electromagnetic gas ballast, II 3/-G Ex h IIC 160 °C Gc II 3/-D Ex h IIIB T160 °C Dc 10°C<Ta<40°C	<b>117 115</b>	<b>117 116</b>
Screw Vacuum Pump SP 630 F water cooled, with purge gas unit and electromagnetic gas ballast, with adapter for RUVAC 2001, II 2/3G Ex h IIC 160 °C Gb / Ex h nA IIC 160 °C Gc II 3/3D Ex h IIIB T160 °C Dc / Ex h tc IIIB T160 °C Dc 10°C<Ta<40°C	<b>117 111V11</b>	<b>117 112V11</b>

All pumps are equipped as standard with an SP-GUARD

For all enquiries and orders relating to category 1 and 2 ATEX products please exclusively use our ATEX questionnaire. You can find this questionnaire at the end of the full-line catalog together with the fax forms or on the Internet under "www.leybold.com" under Media > Downloads > Download Documents > General Documents.

**Ordering Information**
**SP 630 O<sub>2</sub>**

	<b>50 Hz</b>	<b>60 Hz</b>
	<b>Part No.</b>	<b>Part No.</b>
Screw Vacuum Pump SP 630 air cooled, with purge gas unit and electromagnetic gas ballast	<b>117 039</b>	<b>117 040</b>
water cooled, with purge gas unit and electromagnetic gas ballast	<b>117 139</b>	<b>117 140</b>

All pumps are equipped as standard with an SP-GUARD

**Ordering Information**  
**Accessories**

**SCREWLINE SP 630 Standard / SP 630 F Standard**  
**50 Hz / 60 Hz**

	<b>Part No.</b>
Exhaust silencer	<b>119 001</b>
Serviceable silencer	<b>119 004V</b>
Roots pump adapter for RUVAC 1001 <sup>1)</sup> for RUVAC 2001 for RUVAC WH(U) 2500 <sup>1)</sup> for RUVAC WH 4400 <sup>1)</sup>	<b>500 003 173</b> <b>119 021</b> <b>155222V</b> <b>119 024V</b>
Dust filter <sup>2)</sup> Elbow 90° (DN 100 ISO-K) Clamping screws for DN 63-250 ISO-K Centering ring for DN 100 ISO-K	<b>951 72</b> <b>887 26</b> <b>267 01</b> <b>268 06</b>
Purge vent Kit	<b>119 060V</b>
Flushing Kit	<b>119 015V02</b>
Inlet filter adapter DN 100 ISO-K	<b>119 020</b>
Solenoid gas ballast kit, 24 V from serial number 31000530865	<b>119 054V</b>
Non-return valve (DN 100 PN 6)	<b>119 010</b>
Purge gas retrofit kit <sup>3)</sup>	<b>119 030</b>
Castor kit for pump system (Set 4 pieces)	<b>504408V901</b>
Maintenance kit, level 1 (oil change kit) up to serial number 31000197911 from serial number 31000197911	<b>EK 110 000 792</b> <b>EK 110 000 832</b>
Maintenance kit, level 2 (rotor inspection kit)	<b>EK 110 000 793</b>
Purge gas connection servicing kit	<b>EK 110 000 827</b>
Filter for gas ballast	<b>E 110 000 980</b>
Filter for purge gas valve unit	<b>E 110 000 850</b>
Water filter maintenance kit for SP 630 F	<b>EK 110 000 813</b>
Silencer service kit	<b>EK 500 003 475</b>
Seal kit for SP 630 check valve	<b>EK 110 000 815</b>

<sup>1)</sup> Must mount to adapter Part No. 119 021

<sup>2)</sup> For information on the dust filter please refer to the Catalog Part "Oil sealed Vacuum Pumps", Section "SOGEVAC", Chapter "Accessories"

<sup>3)</sup> Not for ATEX pumps and pumps which are equipped with a purge gas unit



# Products

## Dry Screw Vacuum Pumps VARODRY



The VARODRY vacuum pump series is designed and produced by Leybold, in Germany specifically for industrial processes.

Being 100% air-cooled and dry, the VARODRY only consumes electricity, with no extra costs for cooling water supply or oil / oil-filter exchange and disposal. Its low power consumption will save significant operation costs.

With VARODRY vacuum can be easy, efficient, reliable and dry.

The VARODRY series is complemented by the VARODRY HD/O<sub>2</sub> heavy duty, oxygen-handling models and the OEM versions with a reduced footprint for optimal systems integration.

### Advantages to the User

- Effortless installation - just connect to power and process
- Smoothless control - via VSD or regulation valves
- Seamless integration/retrofit - air cooled and easy accessibility
- Minimized total cost of ownership
  - Low upfront investment
  - Best-in-class power consumption
  - Limited maintenance expenses
  - No costs for cooling water and compressed air
  - Competitive at all pressures and over the complete pump life cycle
  - Excellent vapor pumping capacity
  - Quiet, low pitch sound level
- Optimized system uptime
  - Robust pump design, made for industrial applications
  - Based on proven technology and an innovative belt drive
  - Superior performance, even in humid and dusty applications
  - Long-term operation with extended service intervals
- 100 % clean vacuum
  - Completely oil-free
  - Free of any oil emissions or oil leakages

### Typical Applications

The VARODRY is optimized for the challenges found in many industrial applications:

- Repeated and fast cycling:
  - The VARODRY offers a very quick pump down. The pump tolerates atmospheric pressure shocks and repeated evacuation cycles.
- Dust / particle handling:
  - The rotor screw principle and anodization offers the best performance to handle fine, dry dust particles. In the case of large dust amounts, a wide filter portfolio is available.
- Vapor handling:
  - Due to its optimized temperature profile and the built-in gas-ballast, the VARODRY offers a high vapor tolerance, avoiding internal condensation.
- Reactive gas handling:
  - Often vapors (e.g. hydrocarbons) tend to react inside hot dry pumps and built-up internal coatings which can cause pump seizing. The internal temperature profile virtually eliminates this risk.

- Liquid handling:
  - The VARODRY can handle droplets or even liquid slugs as the liquids can flow freely out of the pump.

### Heavy Duty Models VARODRY VD HD/O<sub>2</sub>

VARODRY HD/O<sub>2</sub> is specifically designed with a stainless steel exhaust and built-in purge module. Together, these allow the pump to handle some of the harshest applications in which exhaust gases are usually piped away.

The combination of the above heavy duty features, the completely oil-free VARODRY concept and the extra precautions taken during production to ensure internally hydrocarbon-free surfaces result in a VARODRY HD/O<sub>2</sub> capable of handling up to 100% oxygen. These capabilities have been accredited by a notified body, based on intensive and rigorous testing.

In addition, expensive (PFPE) oil changes are no longer necessary. VARODRY HD/O<sub>2</sub> pump models minimize your total cost of ownership.

## Technical details at a glance

- Intake connection
  - Horizontal or vertical orientation
  - G-thread as standard
  - ISO-KF, ISO-K or NPT thread as accessory
- Exhaust connection
  - G-thread as standard
  - ISO-KF or NPT thread as accessory
  - At lowest position, enabling condensate drainage
- Built-in exhaust silencer
  - Lowest noise emission
  - Drainable design
- Anodized variable pitch rotor
  - Benchmark for efficiency and robustness
  - Lowest power demand in its class
- Shaft seal / bearing protection
  - "Self-cleaning" seal design
  - Optional purge-gas system available
  - No need for seal purge in most industrial applications
- Gas-ballast
  - High vapor tolerance
  - Supports dust handling
- Air-cooled design
  - Low operation cost
  - Simple integration into mobile systems
- Innovative belt-drive
  - Provides synchronization and transmission
  - Proven, long-life technology
  - Easy to maintain via the partly removable enclosure
  - No need for gear lubrication
- Innovative bearing technology
  - Most robust hybrid bearing design
  - Life-time grease lubricated
  - No need for oil exchange
- Enclosure
  - Integrated noise dampening
  - Can be partly removed for convenient pump access
  - Clean and sleek design

## Maintenance and Service

- Minimum maintenance and service requirements:
  - With only two wearing parts (belt and bearings), only minimal efforts are required to keep your pump running at peak performance. At the same moment, the uptime of your facility will be strongly improved.
- User maintenance:
  - The belt can easily be exchanged by the user in less than 30 minutes. The partly removable enclosure makes this really convenient. The belt exchange interval depends on the individual application, typically it is one year. Belt exchange kits and maintenance tools are available.
- Leybold Service:
  - The bearings can be on-site exchanged by trained Service technicians. Typical the bearing lifetime is 3 years. Complete pump-overhauls can be done in one of the many Leybold Global Service hubs. To ensure the highest factory uptime, Leybold offers a fast "pump exchange". Our back-up pools offer flat pump exchange rates, to keep your production running at all times.

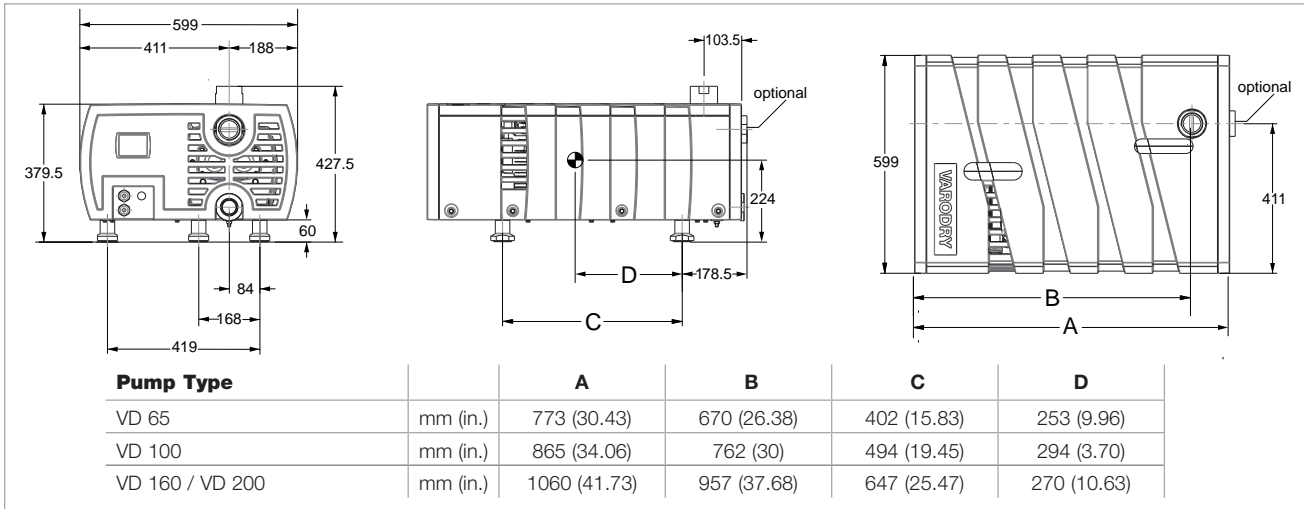

Dimensional drawing for the VARODRY Pumps

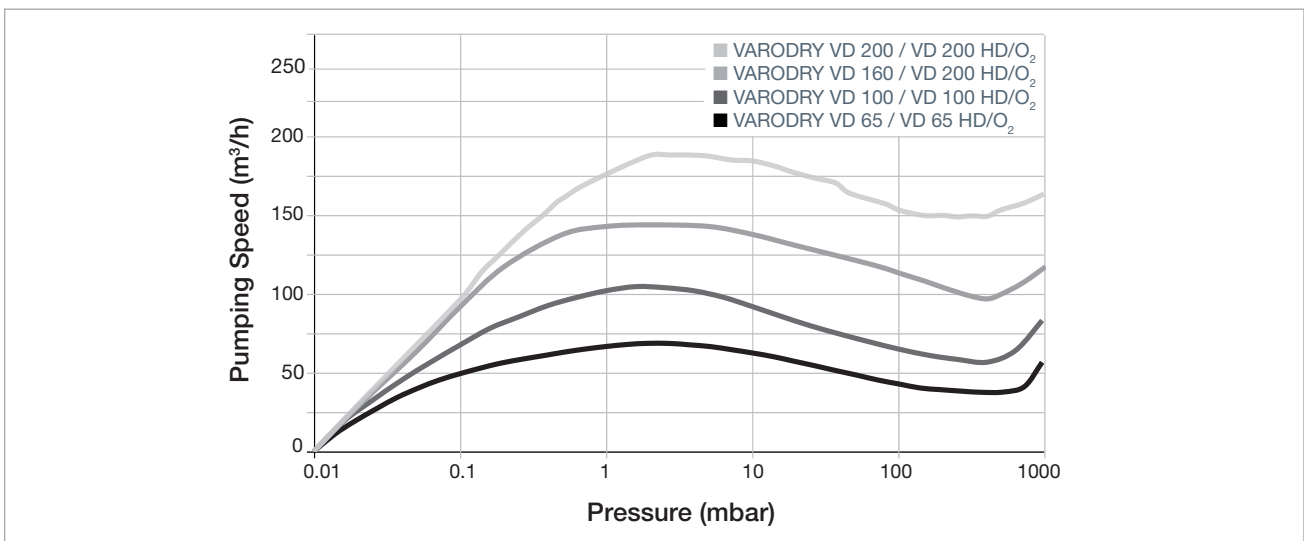

Pumping speed curves

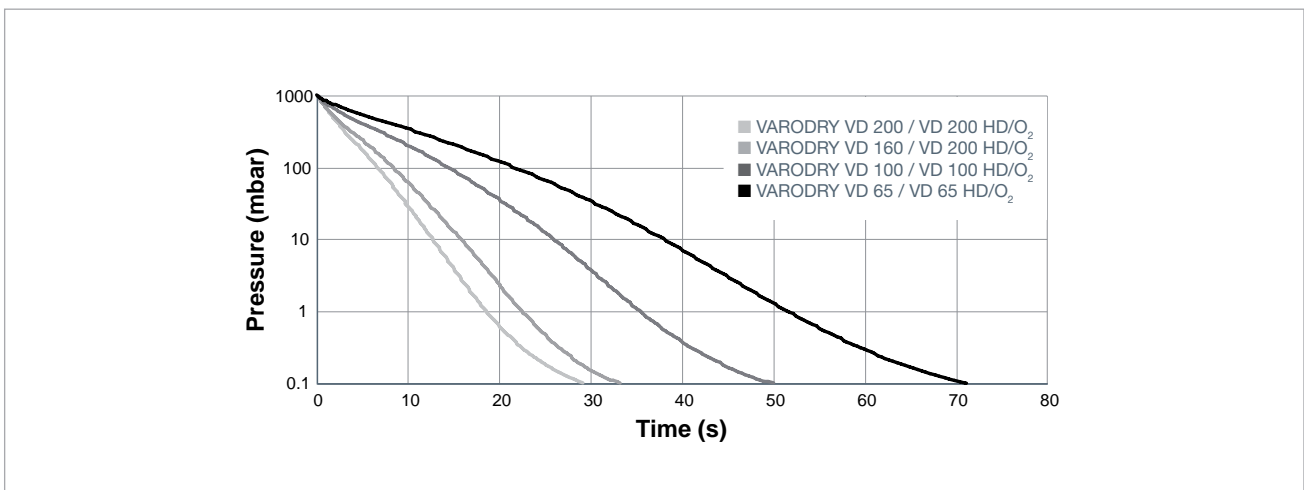

Pump down time for a 100 l chamber, +/-10% tolerance; measurements at operation temperature for a 100l chamber with DN40 pipe and angle valve

**Technical Data**
**VARODRY**

		<b>VD 65</b>	<b>VD 100</b>	<b>VD 160</b>	<b>VD 200</b>
Max. pumping speed without gas ballast	m <sup>3</sup> /h	65	105	150	200
Ultimate pressure without gas ballast	mbar	< 0.01			
with standard gas ballast	mbar				
Max. permissible inlet pressure	mbar	1050			
Max. permissible outlet pressure (rel. to ambient)	mbar	200			
Water vapor tolerance	mbar	60			
Water vapor capacity	kg/h	1.9	2.9	5.2	6.9
Noise level (with built-in silencer) at ultimate pressure (50 / 60 Hz)*	dB(A)	64 / 67		70 / 72	
Permissible ambient temperature	°C	0 to +40			
Mains voltage		50 Hz, 200/400 V ±10%, 3 ph or 60 Hz, 230/460 V ±10%, 3 ph			
Rated motor power	kW	1.5	2.2	3.0	4.0
Protection class	IP	55			
Intake connection		G 2"			
Outlet connection		G 1 1/2"			
Weight, approx.	kg	90	100	130	130

\*According to DIN EN ISO 2151

**Ordering Information**
**VARODRY**

	<b>VD 65</b>	<b>VD 100</b>	<b>VD 160</b>	<b>VD 200</b>
	<b>Part No.</b>	<b>Part No.</b>	<b>Part No.</b>	<b>Part No.</b>
Dry Screw Vacuum Pumps VARODRY				
50Hz, 200/400 V	<b>111 065 V10</b>	<b>111 100 V10</b>	<b>111 160 V10</b>	<b>111 200 V10</b>
50Hz, 200/400 V with purge gas module	<b>111 065 V15</b>	<b>111 100 V15</b>	<b>111 160 V15</b>	<b>111 200 V15</b>
60Hz, 230/460 V	<b>111 065 V11</b>	<b>111 100 V11</b>	<b>111 160 V11</b>	<b>111 200 V11</b>
60Hz, 230/460 V with purge gas module	<b>111 065 V16</b>	<b>111 100 V16</b>	<b>111 160 V16</b>	<b>111 200 V16</b>
60Hz, 200/380 V	<b>111 065 V21</b>	<b>111 100 V21</b>	<b>111 160 V21</b>	<b>111 200 V21</b>
60Hz, 200/380 V with purge gas module	<b>111 065 V26</b>	<b>111 100 V26</b>	<b>111 160 V26</b>	<b>111 200 V26</b>

**Accessories \***
**Soft Starters (mandatory for all VD 160 and VD 200 variants)**

For mains voltage: 400V/50Hz, 460V/60Hz, 380V/60Hz ≥ 11A, 110-230 V AC 200-480V 50/60Hz, control voltage 110-230V AC ≥ 11A, 24 V DC 200-480V 50/60Hz, control voltage 24V DC	-	<b>111005A65</b>
	-	<b>111005A66</b>
For mains voltage: 200V/50Hz, 230V/60Hz, 200V/60Hz ≥ 19A, 110-230 V AC 200-480V 50/60Hz, control voltage 110-230V AC ≥ 19A, 24 V DC 200-480V 50/60Hz, control voltage 24V DC	-	<b>111005A67</b>
	-	<b>111005A68</b>

\* For our full range of VARODRY accessories please refer to page 63

## Technical Data

## VARODRY

### VD 65 HD/O<sub>2</sub> VD 100 HD/O<sub>2</sub> VD 160 HD/O<sub>2</sub> VD 200 HD/O<sub>2</sub>

Max. pumping speed without gas ballast	m <sup>3</sup> /h	65	105	150	200
Ultimate pressure without gas ballast	mbar	< 0.01			
with standard gas ballast	mbar				
Max. permissible inlet pressure	mbar	1050			
Max. permissible outlet pressure (rel. to ambient)	mbar	200			
Water vapor tolerance	mbar	60			
Water vapor capacity	kg/h	1.9	2.9	5.2	6.9
Noise level (with built-in silencer) at ultimate pressure (50 / 60 Hz)*	dB(A)	67 / 70		70 / 73	
Permissible ambient temperature	°C	0 to +40			
Mains voltage		50 Hz, 200/400 V ±10%, 3 ph or 60 Hz, 230/460 V ±10%, 3 ph			
Rated motor power	kW	1.5	2.2	3.0	4.0
Protection class	IP	55			
Intake connection		G 2"			
Outlet connection		G 1 1/2"			
Dimensions [L x W x H]	kg	644 x 488 x 315	736 x 488 x 315	889 x 488 x 315	
Weight, approx.	kg	85	95	105	115

\*According to DIN EN ISO 2151

## Ordering Information

## VARODRY

### VD 65 HD/O<sub>2</sub> VD 100 HD/O<sub>2</sub> VD 160 HD/O<sub>2</sub> VD 200 HD/O<sub>2</sub>

	Part No.	Part No.	Part No.	Part No.
Dry Screw Vacuum Pumps VARODRY 50/Hz, 200/400 V ± 10%, 3 ph	<b>111 065 V35</b>	<b>111 100 V35</b>	<b>111 160V35</b>	<b>111 200 V35</b>
60 Hz, 230/460 V +- 10 %, 3 ph	<b>111 065 V36</b>	<b>111 100 V36</b>	<b>111 160 V36</b>	<b>111 200 V36</b>
60 Hz, 200/380 V +- 10 %, 3 ph	<b>111 065 V37</b>	<b>111 100 V37</b>	<b>111 160 V37</b>	<b>111 200 V37</b>

\* For our full range of VARODRY accessories please refer to page 63

**Ordering Information**
**VARODRY**

	<b>VD 65</b>	<b>VD 100</b>	<b>VD 160</b>	<b>VD 200</b>
	<b>Part No.</b>	<b>Part No.</b>	<b>Part No.</b>	<b>Part No.</b>

**VARODRY**
**VD 65 HD/O<sub>2</sub> VD 100 HD/O<sub>2</sub> VD 160 HD/O<sub>2</sub> VD 200 HD/O<sub>2</sub>**

	<b>Part No.</b>	<b>Part No.</b>	<b>Part No.</b>	<b>Part No.</b>
--	-----------------	-----------------	-----------------	-----------------

**Accessories**

Inlet adapter				
DN 40 ISO-KF, 20 mm				<b>111005A20</b>
G 1 1/4", 10 mm				<b>111005A21</b>
NPT 1 1/4 -11.5, 10 mm				<b>111005A22</b>
NPT 2-11.5, 35 mm				<b>111005A23</b>
DN 63 ISO-K, 27 mm				<b>111005A24</b>
Exhaust adapter				
DN 40 ISO-KF, 20 mm				<b>111005A30</b>
NPT 1 1/2-11.5, 30 mm				<b>111005A31</b>
Inlet non return valve (for inlet pressures > 5 mbar) G 2"				<b>111005A15</b>
Casters				<b>111005A50</b>
Flushing Kit				<b>111005A00</b>

# VARODRY OEM VARODRY DOT



VARODRY OEM and VARODRY DOT vacuum pump versions come without housing for reduced footprint and increased system integrability.

## VARODRY OEM

The VARODRY OEM offers all unique advantages and same performance than our VARODRY series, but with a reduced footprint.

The OEM variants are optimized for systems integration and wherever installation space is limited.

## VARODRY DOT

The VARODRY DOT versions are the perfect choice for all applications involving DOT, e. g. brake filling applications.

The VARODRY DOT contains blow off balls made of DOT resistant EPDM as well as a robust stainless steel silencer tube.

These versions are equipped with a purge module for an enhanced protection of the bearing area against the brake line fluids.

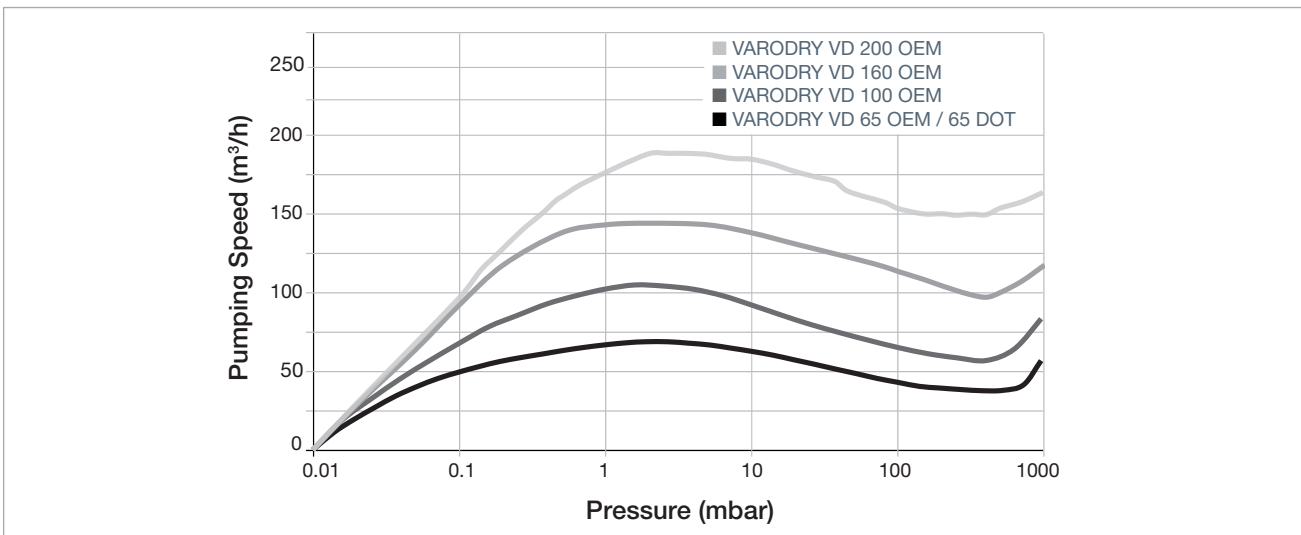

Pumping speed curves

**Technical Data**
**VARODRY**
**VD 65 OEM    VD 100 OEM    VD 160 OEM    VD 200 OEM**  
**VD 65 DOT    VD 100 DOT    VD 160 DOT    VD 200 DOT**

Max. pumping speed without gas ballast	m³/h	65	105	150	200
Ultimate pressure without gas ballast	mbar	< 0.01			
with standard gas ballast	mbar	< 0.1			
Max. permissible inlet pressure	mbar	1050			
Max. permissible outlet pressure (rel. to ambient)	mbar	200			
Water vapor tolerance	mbar	60			
Water vapor capacity	kg/h	1.9	2.9	5.2	6.9
Noise level (with built-in silencer) at ultimate pressure (50 / 60 Hz)*	dB(A)	67 / 70		70 / 73	
Permissible ambient temperature	°C	0 to +40			
Mains voltage		50 Hz, 200/400 V ±10%, 3 ph or 60 Hz, 230/460 V ±10%, 3 ph			
Rated motor power	kW	1.5	2.2	3.0	4.0
Protection class	IP	55			
Intake connection		G 2"			
Outlet connection		G 1 1/2"			
Dimensions (L x W x H)	mm	644 x 488 x 315	736 x 488 x 315	889 x 488 x 315	
Weight, approx.	kg	85	95	105	115

\*According to DIN EN ISO 2151

**Ordering Information**
**VARODRY**
**VD 65 ...    VD 100 ...    VD 160 ...    VD 200 ...**

	Part No.	Part No.	Part No.	Part No.
Dry Screw Vacuum Pumps VARODRY OEM				
50Hz, 200/400 V	<b>111 065 V12</b>	<b>111 100 V12</b>	<b>111 160 V12</b>	<b>111 200 V12</b>
60Hz, 230/460 V	<b>111 065 V13</b>	<b>111 100 V13</b>	<b>111 160 V13</b>	<b>111 200 V13</b>
60Hz, 200/380 V	<b>111 065 V22</b>	<b>111 100 V22</b>	<b>111 160 V22</b>	<b>111 200 V22</b>
Dry Screw Vacuum Pumps VARODRY DOT				
50Hz, 200/400 V	<b>111 065 V45</b>	–	–	–
60Hz, 230/460 V	<b>111 065 V46</b>	–	–	–
60Hz, 200/380 V	<b>111 065 V47</b>	–	–	–

**Accessories**

Soft Starters VD/ND, mandatory			
≥ 11A, 110-230 V AC	–		<b>111005A65</b>
≥ 11A, 24 V DC	–		<b>111005A66</b>
≥ 19A, 110-230 V AC	–		<b>111005A67</b>
≥ 19A, 24 V DC	–		<b>111005A68</b>
Inlet adapter			
DN 40 ISO-KF, 20 mm		<b>111005A20</b>	
G 1 1/4", 10 mm		<b>111005A21</b>	
NPT 1 1/4-11.5, 10 mm		<b>111005A22</b>	
NPT 2-11.5, 35 mm		<b>111005A23</b>	
DN 63 ISO-K, 27 mm		<b>111005A24</b>	
Exhaust adapter			
DN 40 ISO-KF, 20 mm		<b>111005A30</b>	
NPT 1 1/2-11.5, 30 mm		<b>111005A31</b>	
Flushing Kit		<b>111005A00</b>	
Purge Upgrade Kit (VD OEM versions only)		<b>111005A01</b>	

# Products

## Dry Claw Pumps and Systems CLAWVAC



CLAWVAC CP 150 and CLAWVAC system CP 600i

In the CLAWVAC, a pair of claw rotors rotate completely contactless and wear-free in the stator. The CLAWVAC differentiates itself from conventional claw pumps mainly through its material selection. Stainless steel rotors as well as the corrosion-resistant coated vacuum chamber also prove themselves under very harsh process conditions and contribute to a reliable operation.

The systems offer great advantages for a wide range of rough vacuum and over-pressure applications.

The pump design enables extreme robustness, especially for challenging applications which include handling of particles or vapor-contaminated gases.

### Advantage to the User

- Oil-free vacuum generator
- No risk of oil migration into the process
- High resistance to corrosion
- Air-cooled
- Extremely efficient air cooling for optimal operation temperature
- Easy to install
- Very low cost of maintenance
- Stable performance: no influence of outer or gas temperature
- Continuous operation at any inlet pressure without overheating
- High power efficiency
- Can be run on frequency converter to optimize power consumption
- Optional internal flushing for most difficult processes
- Compact design with small Footprint
- Environmentally friendly
- Market-leading low noise level
- Safe operation
- Most robust bearing and seal design

### Typical Applications

- Food Processing
  - Bottling
  - Dairy products (e.g. milking)
  - Vacuum conveying (e.g. in slaughterhouses)
  - Vacuum carcass cleaning
  - Beverage production
- Food Packaging
  - Thermoforming of foil containers
  - Tray sealing
  - Modified Atmosphere Packaging (MAP)
- Woodworking
  - Holding & lifting
  - CNC router
  - Drying & impregnation
- Material Transport & Holding
  - Print & paper (press & post-press)
  - Vacuum conveying
  - Vacuum clamping
- Degassing
  - Li-battery slurry
  - Ceramics & bricks
  - Thermoforming
  - Deep drawing of bathtubs
- Plastic Industry
  - Composite manufacturing
  - Granulate conveying
  - Extruder degassing (e.g. PP, PE, PS)
  - Gluing
- Environmental Engineering
  - Sewage degassing
  - Biogas production
  - Soil remediation

# Dry Claw Pumps CLAWVAC CP 65 to CP 300



Claw vacuum pumps CLAWVAC CP 150 and CP 300

## Accessories and Special Processes

Standard CLAWVAC pumps can replace less-efficient technologies like liquid-ring pumps. When pumping high quantities of liquids, we recommend using liquid separators. When pumping processes with high amounts of solid particles, we recommend to use inlet filters. Please refer to the accessories in our SOGEVAC product catalogue. When pumping gases with more than 21% of oxygen, please use our specially-qualified "CLAWVAC O<sub>2</sub>" versions. We also offer CLAWVAC vacuum pumps without motor to fit with all special customer requirements.

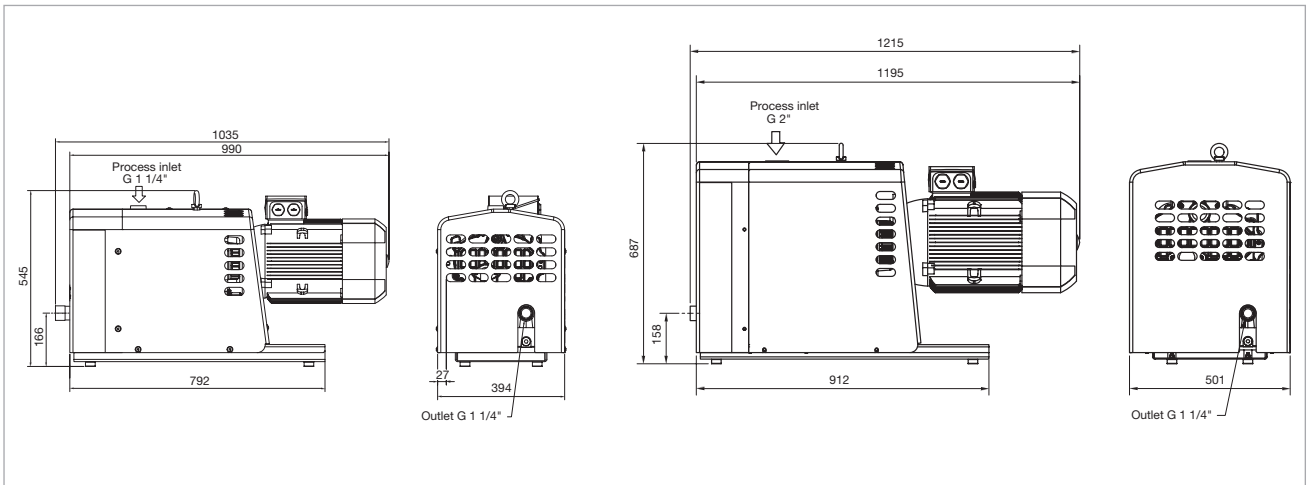

Dimensional drawing – CP 65 and CP / OP 150 left, CP / OP 300 right (dimensions in mm)

## Technical Data

			<b>CLAWVAC</b>		
			<b>CP 65</b>	<b>CP 150</b>	<b>CP 300</b>
Pumping speed	50 Hz	m <sup>3</sup> /h	65	150	300
	60 Hz	m <sup>3</sup> /h	79	184	347
Ultimate vacuum		mbar / Torr	50 / 37.5	50 / 37.5	140 / 105
Continuous operation range		mbar / Torr	50 – 1000 / 37.5 – 750	50 – 1000 / 37.5 – 750	140 – 1000 / 105 – 750
Permissible ambient temperature range		°C / °F	0 – 40 / 32 – 104		
Connections			Inlet: G 1 1/4" or NPT Outlet: G 1 1/4" or NPT	Inlet: G 1 1/4" or NPT Outlet: G 1 1/4" or NPT	Inlet: G 2" or NPT Outlet: G 1 1/4" or NPT
Nominal motor power	50 Hz	kW	1.8	3.7	6.2
	60 Hz	kW	2.2	4.4	7.5
Operation range		Hz	20 – 60		
Noise level (50 Hz / 60 Hz)		dB(A)	66 / 77	75 / 80	77 / 84
Weight		kg	120	160	252
Motor protection class		IP	55		

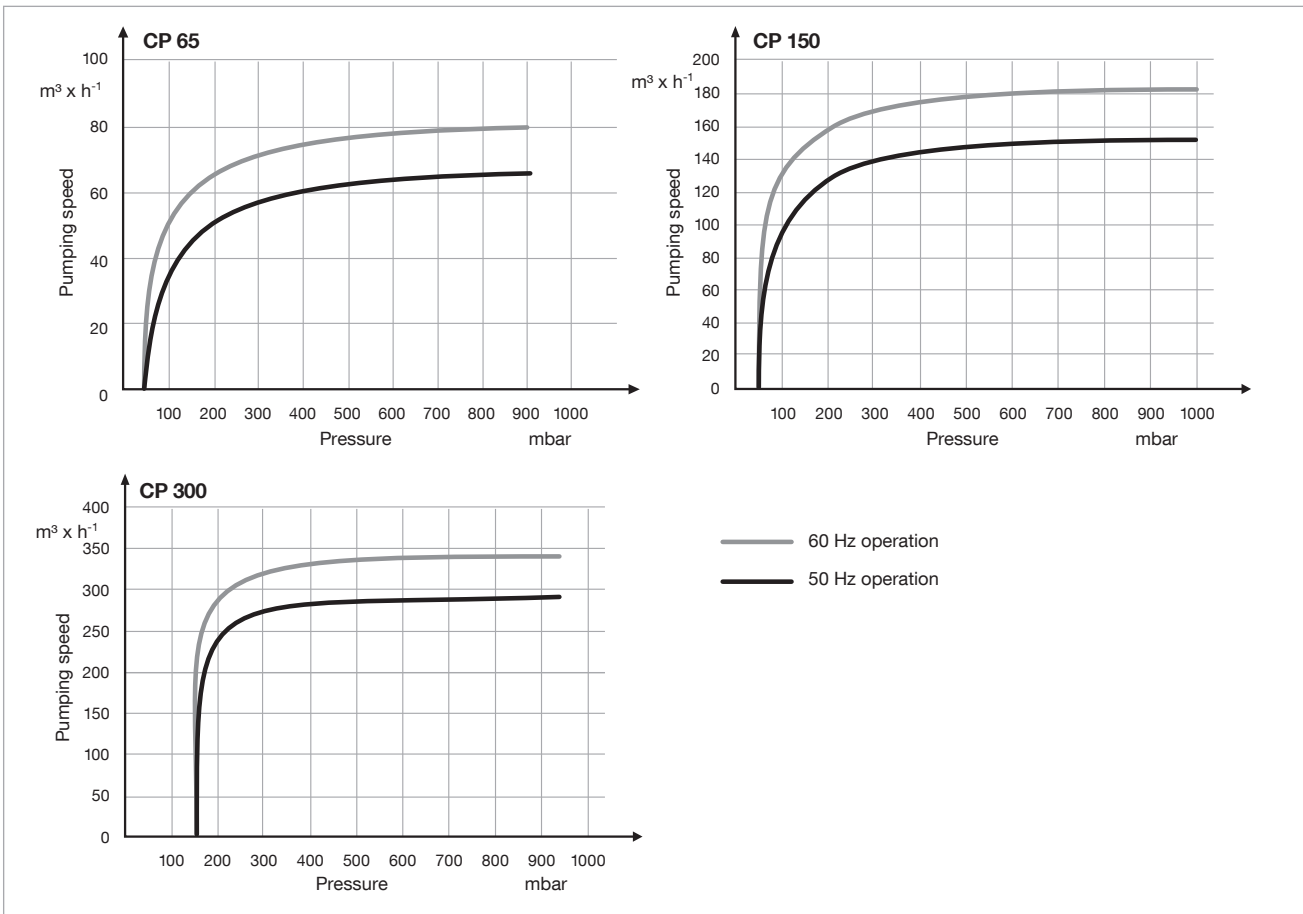

Pumping speed characteristics CP 65, CP 150 and CP 300 right

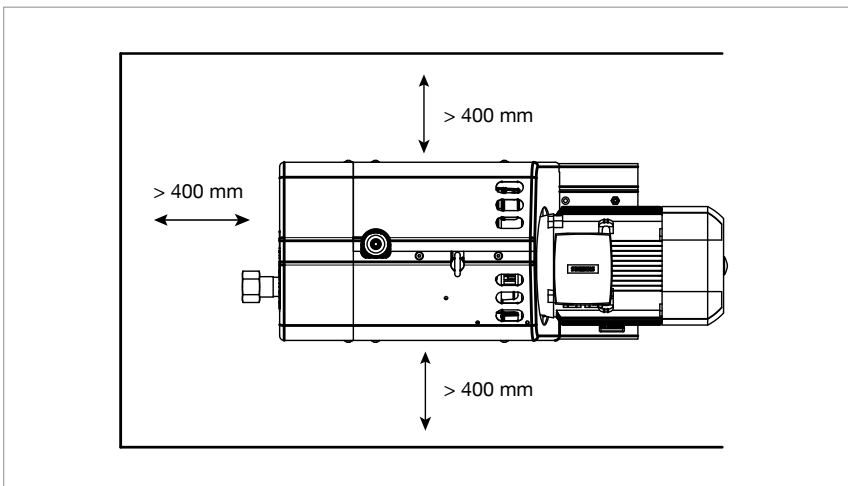

CLAWVAC CP pump installation requirements

## Ordering Information

## CLAWVAC

	<b>CP 65</b>	<b>CP 150</b>	<b>CP 300</b>
	<b>Part. No.</b>	<b>Part. No.</b>	<b>Part. No.</b>
230 V 50 Hz 3Ph	<b>178065V01</b>	<b>178150V01</b>	<b>178300V01</b>
380 V 60 Hz 3Ph	<b>178065V02</b>	<b>178150V02</b>	<b>178300V02</b>
400 V 50 Hz 3Ph	<b>178065V03</b>	<b>178150V03</b>	<b>178300V03</b>
575 V 60 Hz 3Ph	<b>178065V04</b>	<b>178150V04</b>	<b>178300V04</b>
200 V 60 Hz 3Ph	<b>178065V05</b>	<b>178150V05</b>	<b>178300V05</b>
230/460 V 60 Hz 3Ph	<b>178065V07</b>	<b>178150V07</b>	<b>178300V07</b>
200 V 50 Hz 3Ph	<b>178065V08</b>	<b>178150V08</b>	<b>178300V08</b>
230 V 50 Hz 3Ph	<b>178065V01</b>	<b>178150V01</b>	<b>178300V01</b>
380 V 60 Hz 3Ph	<b>178065V02</b>	<b>178150V02</b>	<b>178300V02</b>
400 V 50 Hz 3Ph	<b>178065V03</b>	<b>178150V03</b>	<b>178300V03</b>
575 V 60 Hz 3Ph	<b>178065V04</b>	<b>178150V04</b>	<b>178300V04</b>
200 V 60 Hz 3Ph	<b>178065V05</b>	<b>178150V05</b>	<b>178300V05</b>
230/460 V 60 Hz	<b>178065V07</b>	<b>178150V07</b>	<b>178300V07</b>
200 V 50 Hz 3Ph	<b>178065V08</b>	<b>178150V08</b>	<b>178300V08</b>
380 V 60 Hz 3Ph O <sub>2</sub> for high oxygen	<b>178065V12</b>	<b>178150V12</b>	<b>178300V12</b>
400 V 50 Hz 3Ph O <sub>2</sub> for high oxygen	<b>178065V13</b>	<b>178150V13</b>	<b>178300V13</b>
575 V 60 Hz 3Ph O <sub>2</sub> for high oxygen	<b>178065V14</b>	<b>178150V14</b>	<b>178300V14</b>
200 V 60 Hz 3Ph O <sub>2</sub> for high oxygen	<b>178065V15</b>	<b>178150V15</b>	<b>178300V15</b>
230/460 V 60 Hz O <sub>2</sub> for high oxygen	<b>178065V17</b>	<b>178150V17</b>	<b>178300V17</b>
230 V 50 Hz 3Ph w/o motor	<b>178065V21</b>	<b>178150V21</b>	<b>178300V21</b>
380 V 60 Hz 3Ph w/o motor	<b>178065V22</b>	<b>178150V22</b>	<b>178300V22</b>
Additional silencer at the exhaust G 1 1/4"	<b>178005A05</b>		

# Over-Pressure Claw Pumps

## CLAWVAC OP 150 to OP 300

### Technical Data

### CLAWVAC

		OP 150	OP 300
Max. volume flow	50 Hz	30.2	66
	60 Hz	40	82
Max. over-pressure	bar(g) / psi	2.5 / 36	
Permissible ambient temperature range	°C / °F	0 – 40 / 32 – 104	
Connections		Inlet: G 1 1/4" or NPT Outlet: G 1 1/4" or NPT	Inlet: G 2" or NPT Outlet: G 1 1/4" or NPT
Nominal motor power	50 Hz / 60 Hz kW	14	22
Operation range	Hz	20 – 60	
Noise level (50 Hz / 60 Hz)	dB(A)	75 / 80	77 / 82
Weight	kg	196	262
Motor protection class	IP	55	

### Ordering Information

### CLAWVAC

	OP 150	OP 300
	Part. No.	Part. No.
230 V 50 Hz 3Ph	<b>178150P01</b>	<b>178300P01</b>
380 V 60 Hz 3Ph	<b>178150P02</b>	<b>178300P02</b>
400 V 50 Hz 3Ph	<b>178150P03</b>	<b>178300P03</b>
575 V 60 Hz 3Ph	<b>178150P04</b>	<b>178300P04</b>
200 V 60 Hz 3Ph	<b>178150P05</b>	<b>178300P05</b>
230/460 V 60 Hz 3Ph	<b>178150P07</b>	<b>178300P07</b>
200 V 50 Hz 3Ph	<b>178150P08</b>	<b>178300P08</b>



# Dry Vacuum Claw Pump Systems

## CPi 600 / 900 / 1200



CLAWVAC vacuum system CPi 1200

When customers need more than 350 m<sup>3</sup>/h, we offer our range of CLAWVAC systems.

CLAWVAC systems offer all the benefits of CLAWVAC pumps, and more:

- Dry vacuum: central vacuum systems without any risk of oil contamination
- “Plug & pump”: an easy-to-install package to replace old technologies
- Ready for harsh processes, like vacuum conveying of dusty, humid or greasy products
- Economical to run: the on-board controller will enable to optimize pumping speed to the process needs and offer energy savings.

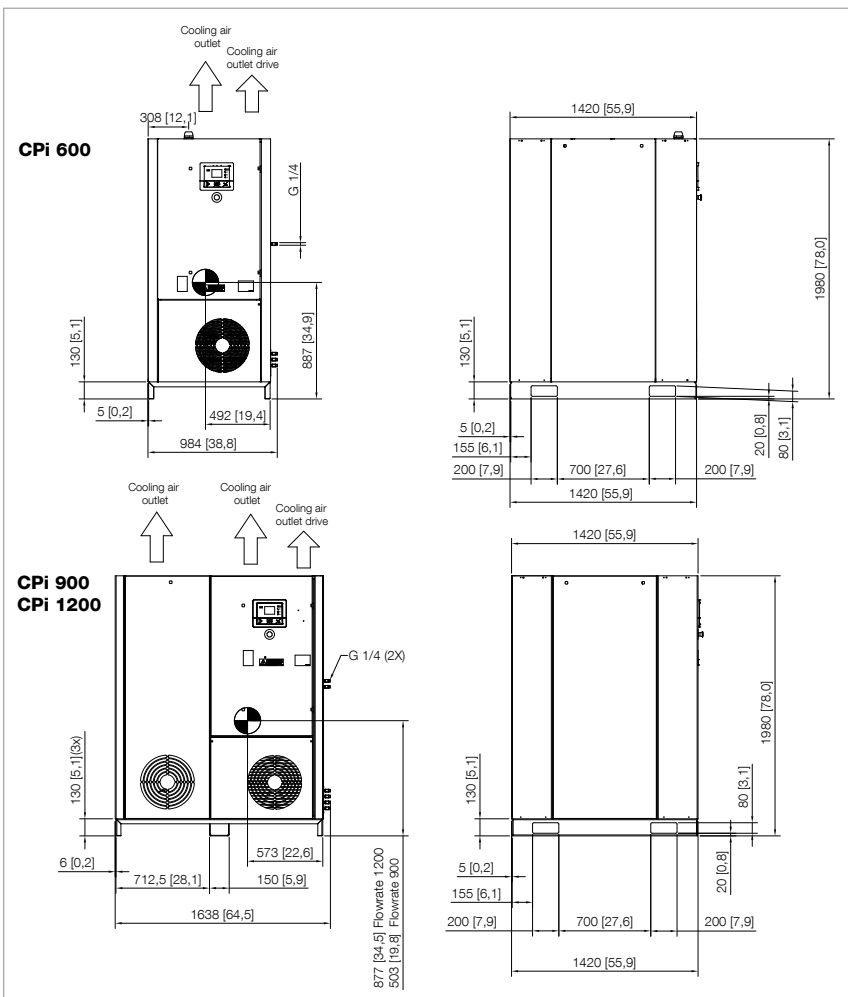

Dimensional drawing – CPi 600 (top), CPi 900 / CPi 1200 (bottom). All dimensions in mm

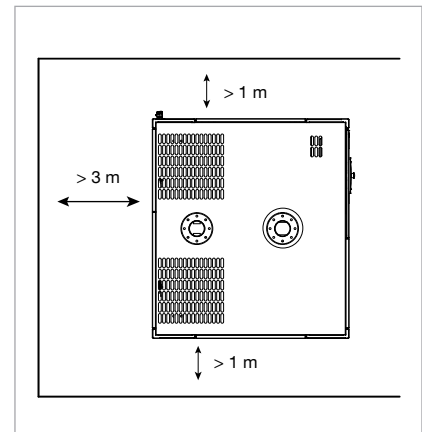

CLAWVAC CPi system installation requirements



Internal layout of a CLAWVAC vacuum system CPI 600

CLAWVAC SYSTEMS can replace less-efficient technologies like liquid-ring pumps and bring savings in energy and water consumption.

When pumping high quantities of liquids, we recommend using liquid separators.

When pumping in processes with high amounts of solid particles, we recommend to use an inlet filter.

Please contact Leybold for more information.

## Technical Data

### CLAWVAC

		CPI 600		CPI 900		CPI 1200	
		50 Hz	60 Hz	50 Hz	60 Hz	50 Hz	60 Hz
Pumping speed min./max.	m <sup>3</sup> /h cfm	112 - 604 67 - 362	112 - 650 67 - 390	112 - 874 67 - 524	112 - 966 67 - 580	112 - 1143 67 - 686	112 - 1283 67 - 686
Pumping pressure range	mbar Torr	150 - 1000 112 - 750					
Motorshaft power	kW hp	13.7 18.4	15.2 20.4	19.9 26.6	21.4 28.7	26.1 35	30 40
Noise level Min. speed - max. speed	dB(A)	74	75	73	74	73	74
Ambient temperature	°C °F	0 - 46 32 - 115					
Weight	kg lbs	1096 2416	1096 2416	1521 3335	1521 3335	1821 4015	1821 4015
Protection class	IP	54					
Supply voltages *		380 - 460V, 3ph					
Connections	Inlet flange Outlet flange	DN DN	80 PN6 80 PN6	100 PN10 100 PN10	100 PN10 100 PN10	100 PN10 100 PN10	100 PN10 100 PN10

## Ordering Information

### CLAWVAC

	CP 65	CP 150	CP 300
	Part. No.	Part. No.	Part. No.
400 V 50 Hz 3Ph CE	<b>178600V01</b>	<b>178900V01</b>	<b>1781200V01</b>
460 V 60 Hz 3Ph UL	<b>178600V02</b>	<b>178900V02</b>	<b>1781200V02</b>
380 V 60 Hz 3Ph CE	<b>178600V03</b>	<b>178900V03</b>	<b>1781200V03</b>