

High Vacuum Pumps

TURBOVAC / TURBOVAC MAG

Turbomolecular Pumps

DIP / DIJ / OB

Oil Diffusions Pumps

COOLVAC

Cryo Pumps

COOLPOWER

Cold Heads

COOLPAK

Compressor Units

240.00.02

Excerpt from the Leybold Full Line Catalog (Edition 2025/02)

Catalog Part High Vacuum Pumps

Contents

High Vacuum Pumps

Turbomolecular Pumps TURBOVAC / TURBOVAC MAG	6
General to TURBOVAC Pumps	
Applications for TURBOVAC Pumps	12
Applications for TURBOVAC Pumps	13
Products	
Turbomolecular Pumps with Hybrid Rotor Suspension (mechanical/magnetic)	14
General Information about TURBOVAC i / iX-Pumpen	14
with integrated Frequency Converter	
TURBOVAC 90 i, 250 i, 350 i, 450 i, 850 i and 950 i.	22
with integrated Frequency Converter and integrated Vacuum System Controller	
TURBOVAC 90 iX, 250 iX, 350 iX, 450 iX, 850 iX and 950 iX	22
Special Turbomolecular Pumps	38
Turbomolecular Vacuum Pumps with Mechanical Rotor Suspension	40
with Frequency Converter for Attaching or Separate / with or without Compound Stage	40
Turbomolecular Vacuum Pump with Magnetic Rotor Suspension	44
TURBOVAC MAG iS	44
MAG INTEGRA	51
Accessories	
Vibration Absorber	57
Flange Heater for CF High Vacuum Flanges	57
Fine Filter	58
Solenoid Venting Valve	58
Power Failure Venting Valve	58
Power Failure Venting Valve, Electromagnetically Actuated	58
Purge Gas and Venting Valve	59
Gas Filter to G 1/4" for Purge Gas and Venting Valve	59
Accessories for Serial Interfaces	
RS 232 C and RS 485 C	60
PC Software LEYASSIST	60
Interface Adaptor for Frequency Converter	
with RS 232 C/RS 485 C Interface	60
Miscellaneous	
Services	61
Oil Diffusion Pumps DIP, DIJ, OB	62

General

Applications and Accessories	63
Oil for Diffusion Pumps	63
for different fields of application	63
for different pump types	64

Products

DIP Pumps, Water-Cooled	67
DIJ Pumps, Water-Cooled	71
Oil Booster OB 6000 to OB 18000	75

Accessories

Astrotorus Baffles	77
Temperature dependant Switching Components for Automatic Pump System Control	79
Monitoring Instruments	80
Energy Efficiency Controller	81
Right-Angle Valves, DN 250 ISO-K to DN 1000 ISO-F, Electropneumatically Operated	83

Cryo Pumps, Cold Heads, Compressor Units

COOLVAC / COOLPOWER / COOLPAK	85
--	-----------

General

Applications and Accessories, Cryo Pumps	85
Applications and Accessories, Cryogenics	86
Cryo Pumps	87
Cold Heads	89
Refrigerating Capacity of Cryogenic Cold Heads	91
Compressor Units	92

Products Cryo Pumps

Cryo Pumps with fully Automatic Control, iClassicLine	93
COOLVAC 1500 iCL	93
COOLVAC 2000 iCL	95
COOLVAC 3000 iCL	95
COOLVAC 5000 iCL	99
COOLVAC 10000 iCL	99
COOLVAC 18000 iCL, COOLVAC 30000 iCL, COOLVAC 60000 iCL	103
Cryo Pumps with Liquid Nitrogen Cooling of Radiation Shield and Baffle of Cryo Pump	106
COOLVAC 30000 BL LN ₂ and COOLVAC 60000 BL LN ₂	106

Products Cryogenics

Cold Heads, Pneumatically Driven	109
Single-Stage Cold Heads COOLPOWER 50 and 140 T	109
Dual-Stage Cold Heads COOLPOWER 7/25 and 5/100	111
Cold Heads, Mechanically Driven	113
Single-Stage Cold Head COOLPOWER 250 MD	113
Dual-Stage Cold Head COOLPOWER 10 MD	113
Compressor Units for Pneumatically Driven Cold Heads and Pumps, Water Cooling	117
COOLPAK 2000/2200	117
COOLPAK 6000 H/6200 H/6000 HD	119
Compressor Units for Mechanically Driven Cold Heads and Pumps, Water Cooling.....	121
COOLPAK 6000 HMD/6200 HMD	121
General Accessories for Compressor Units COOLPAK 2000, 6000 H	123

Accessories for Cryo Pumps / Cryogenics

Controllers and Monitoring Units for Cryo Pumps	125
Control and Display Unit CRYOVISION	125
COOLVAC ProfiBus Module	127
COOLVAC iClassicLine	129
Single System Configuration	129
Dual and Multiple System Configuration	130
Low Temperature Measuring Instrument MODEL 211S	132
Temperature Sensor.....	133

General to TURBOVAC Pumps

Turbomolecular vacuum pumps (TURBOVAC) are used in applications which require a clean high or ultrahigh vacuum like, for example, in research, development or in industrial fields like the semiconductor industry, analytical instrumentation or coating technology.

Principle of Operation

In principle, the turbomolecular pump is a turbine rapidly revolving in a housing where the rotor stages of the turbine

are equipped with a number of rotor blades. Located between the rotating rotor blades are stationary stator disks with blades arranged in the opposite direction. By means of a momentum transfer from the rotating rotor blades to the gas molecules their initially nondirectional thermal motion is changed in to a directional motion from the inlet flange of the pump in the axial direction towards the forevacuum flange. In the molecular flow range (i.e. at pressures below 10^{-3} mbar (0.75×10^{-3} Torr)) the

mean free path of the gas molecules is larger than the spacing between the rotor and the stator blades (typically a few tenths of a millimetre). Correspondingly the molecules chiefly collide with the optically dense rotor blades, resulting in a highly efficient pumping action. In the laminar flow range (i.e. at pressures over 10^{-1} mbar (0.75×10^{-1} Torr)) the effect of the rotor is impaired by frequent collisions between molecules themselves. For this reason, a turbomolecular pump is not capable of pumping gases at atmospheric pressure.

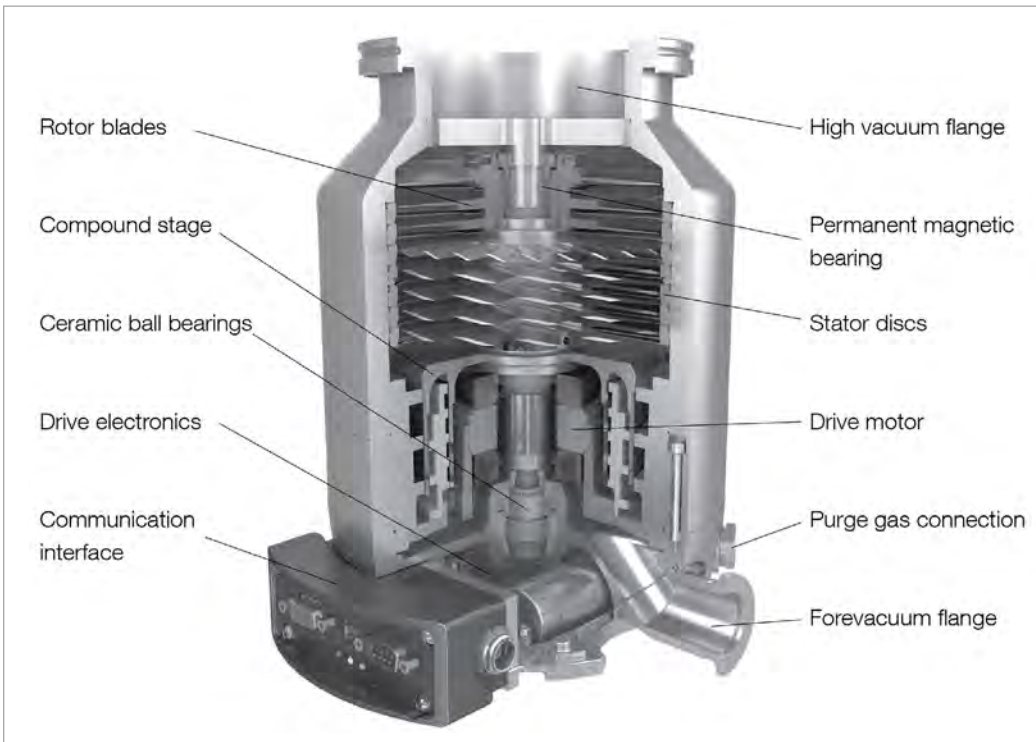

Sectional drawing of a turbomolecular pump (TURBOVAC i)

Rotor Bearing

Leybold offers different rotor bearing systems. A purely classic mechanical type of rotor bearing (TURBOVAC) or a magnetic rotor bearing (TURBOVAC MAG) and also

a hybrid bearing (TURBOVAC i / iX) where the bearing on the forevacuum side is a ceramic ball bearing lubricated for life and where the bearing on the high vacuum side is implemented by way of a non-wearing magnetic bearing.

Typical for all these types of bearing is that they do not require any lubricating oil which under circumstances like standstill of the pump might diffuse back into the vacuum chamber due to the lack of any pumping action.

Drive Electronics/Control Unit

Driving and monitoring the turbomolecular pump requires an electronic frequency converter (inverter). The frequency converter delivers the driving voltage and the output frequency for the motor and also automatically monitors the system. Optimum running up of the pump rotor is attained by a steadily increasing voltage and frequency feed. After attaining the nominal speed, the start-up current is reduced in a controlled manner to the level necessary for normal operation.

The frequency converter and the motor of the TURBOVAC have been designed for a minimal drop of speed even at high intake pressures. This ensures the highest possible gas throughput also in the transition range from molecular to viscous flow

Depending on the given system and installation conditions, the control unit may be supplemented by a comprehensive range of optional accessories facilitating easy integration within existing installations.

Forevacuum Pump

Since turbomolecular pumps are not capable of compressing directly against atmospheric pressure their operation will always require a sufficiently rated forevacuum pump. For the classic rotor arrangement with rotor blades, generally two-stage rotary vane pumps (TRIVAC) will be suitable. In some cases also single-stage rotary vane vacuum pumps (SOGEVAC BI) or dry compressing vacuum pumps (SCROLLVAC plus, ECODRY plus) can be chosen. In the case of the wide range variant where the rotor is equipped with an additional compression stage (compound stage) also diaphragm vacuum pumps (DIVAC) may be used.

Characteristic Quantities

Pumping speed (volume flow rate)

The pumping speed "S" is the conveyed volume flow through the intake opening of the pump. It is dependent on the type of gas so that for this reason the nominal pumping speed, i.e. the maximum attainable pumping speed of the pump is commonly stated for air, respectively nitrogen. In the field of high vacuum engineering it is common to state the pumping speed in the unit of measurement [l/s]. The pumping speed is a nonlinear function of the inlet pressure $S = S(p_i)$.

Gas throughput

Gas throughput "Q", unit of measurement [mbar x l/s] is linked to the pumping speed through the inlet pressure.

$$Q = Q(p_i) = p_i \times S(p_i).$$

Compression

Compression "K" is defined as the ratio between the pressure on the forevacuum side of the turbomolecular pump and the pressure on the high vacuum side.

$$K = K(p_w) = p_w / p_{HV}$$

Compression is dependent on the type of gas.

Ultimate pressure (base pressure)

The ultimate pressure " p_{ult} " of a turbomolecular pump which can be baked out is defined through the ratio between forevacuum pressure and compression ratio which is attained in a test chamber 48 hours after a 24-hour bake-out (degassing) of the measurement arrangement.

$$p_{ult} = p_{FV} / K_0.$$

The maximum attainable ultimate pressure depends among other things on the cleanliness of the apparatus, the type of forevacuum pump used, the types of seals used for the high vacuum flange and the bake-out conditions.

TURBOVAC Product Line

The TURBOVAC pumps are turbomolecular pumps with mechanical rotor suspension which are used in the pressure range from 10^{-1} mbar (0.75×10^{-1} Torr) to 10^{-10} mbar (0.75×10^{-10} Torr). Pumping speeds for air vary from 35 l/s (inlet flange diameter = 40 mm (1.57 in.)) to 925 l/s (inlet flange diameter = 200 mm (7.87 in.)).

Besides a variant with extremely reliable ceramic ball bearings on the forevacuum and the high vacuum side, Leybold also offers a line of turbomolecular pumps equipped with hybrid bearings which on the forevacuum side are equipped with a ceramic ball bearing and on the high vacuum side with a permanent magnetic bearing (TURBOVAC i line).

Owing to their compact design and ease of operation, these pump lines are

used in all high vacuum and ultrahigh vacuum fields of application. In particular, the TURBOVAC pumps are running very successfully in mass spectrometers, in CD, DVD and hard disk production units, in the manufacture of large area optical coatings, in non-corrosive semiconductor production processes and in laboratories as well as research institutes.

The most important advantages of the TURBOVAC product line are:

- Stress free operation with a proven robust design
- Unrivalled performance with speeds up to 60% above reference products
- Minimum application impact, low vibration and oil free operation
- Flexible customizable product with multiple control options
- The Leybold Promise - the right product for you backed by the Leybold Experts



TURBOVAC 350 iX

TURBOVAC MAG Product Line

The TURBOVAC MAG pumps are turbomolecular pumps with magnetic rotor suspension which are used in the pressure range from 10^{-1} mbar (0.75×10^{-1} Torr) to 10^{-10} mbar (0.75×10^{-10} Torr). Pumping speeds for air vary from 300 l/s (inlet flange diameter = 100 mm (3.94 in.)) to 2,200 l/s (inlet flange diameter = 250 mm (12.6 in.)).

The TURBOVAC MAG pumps are mostly installed in areas that require noise-free and vibration-free operation, have to be free of hydrocarbons and require long maintenance intervals. Electron beam microscopy, analytical technology, R & D as well as large area & flat panel display coating are important areas of application for these pumps.

The most important advantages of the TURBOVAC MAG product line are:

- Hydrocarbon-free pumps for the generation of clean high and ultrahigh vacuum conditions
- High performance in any orientation
- High degree of operating reliability
- Extremely low vibration
- Almost maintenance-free



TURBOVAC MAG 2200 iPL

Use of Turbomolecula Pumps in Analytical Instruments

All modern analytical methods for gas, liquid and plasma analysis – like for example GC-MS, LC-MS and ICP-MS – rely on mass spectrometers and for this reason require adequate high vacuum conditions. Also in electron microscopes and many surface analysis instruments the production of a high vacuum is essential. In over 90% of all high vacuum applications, the turbomolecular pump has been found to be ideal. Thanks to the hydrocarbon-free vacuum, compact design, very simple and almost maintenance-free operation it has often displaced above all the diffusion pumps.

On the basis of decades of experience and in cooperation with research facilities and the manufacturers of analytical instruments, Leybold has continually optimized its products.



TURBOVAC 950 i

Through the TURBOVAC wide range series, a further improvement has been attained, making available to users in the area of analytical engineering highly flexible and reliable products.

Owing to the modular concept the user may adapt the vacuum system precisely to his requirements. The components can be integrated perfectly and thus find the most cost-effective system configuration. Through the introduction of the TURBOVAC multi inlet series, Leybold has, based on special customer requirements, achieved a major step ahead for analytical instruments.

Two or more analysis chambers can be pumped down simultaneously by a single multi-inlet pump. These pumps have been tailored for pumping speed and gas throughput in order to attain a higher detection sensitivity of analytical systems, for a smaller footprint and an increased sample throughput, for example. The benefits for the customers are the extreme compactness of the vacuum systems without sacrificing performance density, simple installation, stable vacuum connections and, compared to the use of discrete individual pumps, significantly lower investment costs for the entire system. The cartridge solution, moreover, allows for an innovative and cost-effective design of the customer's system and during servicing a simple replacement of the active unit without involved assembly work and leak searching.

Cartridge benefits, which convince with:

- Higher effective pumping speed
- No losses in conductance
- Compact vacuum system
- Easy pump replacement without having to disassemble the highly sensitive mass spectrometer chambers

The benefits for the customers are reflected by the efficiency of the analytical instruments:

- Increase in detection sensitivity
- Smaller analytical systems
- Increase in sample throughput
- Reduction of system costs
- Lower maintenance costs

In combination with backing pumps like the SOGEVAC, TRIVAC, ECODRY plus or SCROLLVAC plus, Leybold is able to offer the best vacuum system optimized for all major applications in the area of analytical instrumentation.



TURBOVAC i Multi Inlet

Use of Turbomolecular Pumps in the Area of Coating Systems or other Industrial Applications

Many coating processes like large area coating, wear protection or decorative coating as well as industrial installations like furnaces require high vacuum conditions. This is the only way to ensure that the formed layers will be uniform and adhere to the substrate, or process chambers are clean enough to guarantee a good product quality..

By pumping the vacuum chamber down to pressures in the range of 10^{-6} mbar (0.75×10^{-6} Torr), interfering gas and water molecules are removed from the process chamber. The process pressure of coating applications depends on the kind of process: e.g. sputtering uses pressure

ranges of 10^{-3} mbar (Torr), in evaporation processes pressures between 10^{-4} and 10^{-5} mbar (Torr) are needed.

The turbomolecular pump meets all requirements of the customers as to a hydrocarbon-free vacuum, very simple operation, compact and robust design and nearly maintenance-free operation in an almost ideal manner. The range of pumps from Leybold includes pumps with flange diameters ranging from 40 mm to 250 mm (1.57 in. to 9.84 in.) nominal width.

Thus the right pump is available for each application.



Coating of architectural glass

Use of turbomolecular pumps in research and development

In many applications in which new ideas shall be transformed into technical processes, vacuum technology is a basic requirement for being able to implement these processes at all.

Turbomolecular pumps from Leybold are being used widely in the research and development field. Since the application requirements differ widely, for

example between university basic research, industrial development, research and large laboratories, the right component or the vacuum system can be selected from the comprehensive range of equipment being offered.

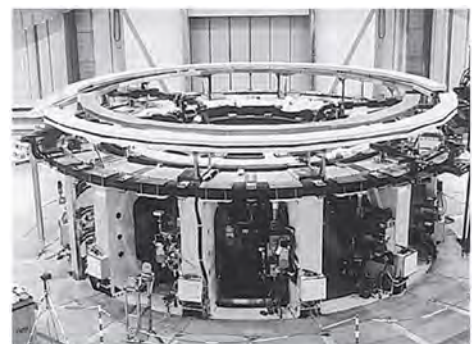

Nuclear fusion technology

Applications for TURBOVAC Pumps

Pumps								
	TURBOVAC 90/250/350/450/850/950 i	TURBOVAC 90/250/350/450/850/950 iX	TURBOVAC i Multi Inlet	TURBOVAC SL 80	MAG W 300/400/600/700 iP	MAG W 1300/1600/1700/2200 iP(L)	MAG W 1601/2201 iP(L)	MAG W 300/400/600/700 P
Applications								
Analytical Instruments								
Leak detectors	■			■	■	■		■
Mass spectrometers	■		■	■	■	■		■
Gas chromatography (GC-MS)	■		■	■	■	■		■
Liquid chromatography (LC-MS)	■		■	■	■	■		■
Quadrupol time of flight (Q-TOF)				■	■	■		■
Matrix assisted laser desorption time of flight (MALDI-TOF)	■		■		■	■		■
Inductively coupled plasma mass spectrometry (ICP-MS)	■		■		■	■		■
Coating								
Flat panel displays					■	■	■	■
Optical coating	■	■			■	■	■	■
Large area coating						■	■	
Decorative coating	■					■	■	
Metallization	■					■	■	
Wear protection	■					■	■	
Metallurgy						■	■	
Heat treatment						■	■	
Degassing						■	■	
Furnace	■					■	■	
Electron beam welding						■	■	
R & D (Research and Development)								
Surface analysis	■			■	■	■		■
UHV / XHV systems	■	■		■	■	■		■
Particle accelerators					■	■		■
Fusion experiments					■	■		■
Space simulation					■	■		■
Semiconductor Processes								
Load locks and transfer chambers	■	■		■	■	■	■	■
PVD	■				■	■	■	■
Ion implantation					■			■

Applications for TURBOVAC Pumps

Pumps

High Vacuum Pumps

	TURBOVAC 90/250/350/450/850/950 i	TURBOVAC 90/250/350/450/850/950 iX	TURBOVAC i Multi Inlet	TURBOVAC SL 80	MAG W 300/400/600/700 iP	TMAG 1601/2201 iP(L)	MAG W 300/400/600/700 P
Applications							
Integrated Frequency Converter	■	■	■		■	■	■
External Frequency Converter				■			
External Frequency Converter and Power Supply							■
24VDC Display Unit TURBO.CONTROL i	■	■					
Pump control unit with Power Supply TURBO.CONTROL 300	■	■					
Power Supply	■	■	■	■	■		
Mounting Kit	■	■	■				
Inlet screen / Splinter guard	■	■	■	■	■	■	■
Vibration absorber	■	■	■	■	■		■
Air cooling unit	■	■	■	■	■		■
Water cooling kit	■	■	■	■	■		■
Flange heaters for CF flanges	■	■	■	■	■		■
Venting valve	■	■	■	■	■		■
Purge gas valve	■	■	■	■	■	■	■
Purge gas and venting valve				■	■	■	
Power failure venting valve	■	■	■	■	■	■	■
Electronic brake module					■		■
Relay box	■	■	■				
Accessories for serial interfaces	■	■	■	■	■	■	■
Control Software for TURBOVAC	■	■	■	■	■	■	■

General Information about TURBOVAC i / iX Pumps

Turbomolecular Pumps with Hybrid Rotor Suspension (mechanical/magnetic)

TURBOVAC i / iX

The TURBOVAC i / iX series is a modular line of turbomolecular vacuum pumps. With the integrated drive electronics (frequency converter) it forms a single unit.

In the development of the TURBOVAC i / iX special emphasis was placed on the maximum attainable pump performance in consideration of its footprint. The specially developed rotor/stator design guarantees excellent performance data as to pumping speed, gas throughput and compression also for light gases.

In all pumps of this line, the bearing consists of a non-wearing permanent magnetic bearing on the high vacuum side and an oil-free ceramic ball bearing with lifetime-lubrication on the forevacuum side. For this reason, the usually required standard maintenance involving an oil change is no longer necessary. The ceramic ball bearing is replaceable on-site, should this be required.

The pumps are equipped as standard with a venting and purge gas port for directly connecting a venting valve, purge gas valve or purge gas throttle to the pump.

Overview of Variants

Electronics Variants

All pumps are equipped with integrated drive electronics with a 24 V/48 V or 48 V power supply which controls the amount of drive power and which monitors all pump functions.

The individual requirements with regard to communication interfaces and the functional scope of the driving options for accessory components can be covered through a number of different electronics variants.

Owing to the many possible combinations (electronics, pump stage design, housing and the range of accessories) the TURBOVAC i / iX can be flexibly adapted to the specific application in almost all cases.

For example, in comparison with the TURBOVAC i, the TURBOVAC iX is equipped with an integrated vacuum system control unit which drives accessory components like vacuum gauges, valves, fans and forevacuum pumps. Moreover, numerous optionally available communication interfaces facilitate easy integration within your installation. The pump stage design (rotor, stator and Holweck stage) can be selected specifically in consideration of the respective process requirements and offers variants for highest possible gas throughput, pumping speed and/or compression in single or multi-chamber systems. Equally comprehensive is the range of housing and flange variants being offered where the vacuum connections can be adapted flexibly to the on-site installation conditions. The wide range of accessories completes the TURBOVAC i / iX line thereby extending the fields of application for these pumps.

Advantages for the User

- High pumping performance from a compact size
- Cost-effective price-to-performance ratio
- Highly reliable, maintenance-free bearing concept without oil lubrication
- Owing to the overall modular concept, individually adaptable to the respective conditions and requirements
- Variety of housings and flange options
- Easy and easily adaptable installation, any mounting position
- Easy process integration due to the numerous interfacing options
- Flexible accessory options (power supply, cooling, heating, venting, installation etc.)



Left: **TURBOVAC i** with standard interface

Centre: **TURBOVAC i** with Anybus interface extension

Right: **TURBOVAC iX** with integrated vacuum system control unit and Anybus interface extension

Electronics Variants

TURBOVAC i (Standard)

Cost-effective solution equipped with basic functions and interfaces.

- Internal 24/48 V DC or 48 V frequency converter
- Status LEDs
- Accessory connection for up to 2 controllable accessory components
- User-friendly interfaces (USB, RS 485, 15-pin digital I/O)



Standard interface USB, RS 485 and 15-pin digital I/O for TURBOVAC i

TURBOVAC i

(Anybus interface extension)

Features like TURBOVAC i, additionally:

- User-friendly interfaces (USB, 15-pin digital I/O) and Anybus interface instead of the RS 485 for further interface options: RS 232, Profibus, ProfiNET, EtherCAT and Ethernet/IP (further interfaces upon request)
- TURBOVAC 850 i and 950 i also available as IP 54 versions

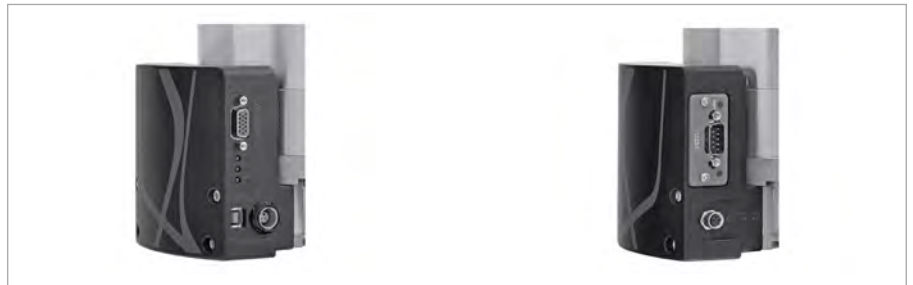

Anybus interface expansion for TURBOVAC i

TURBOVAC iX

(Vacuum system control unit)

With integrated vacuum system control unit and Anybus interface extension.

Features like TURBOVAC i (Anybus interface extension), additionally:

- 3 outputs for controlling vacuum pump accessories
- 1 vacuum gauge head connection for powering and data recording of vacuum gauge heads and application of pressure data for pump system control
- Flexibly programmable software, for customising the configuration of the control connections



Integrated vacuum system control unit of the TURBOVAC iX

Performance Variants



TURBOVAC i / iX

The standard variant for HV / UHV applications and compact pump system solutions. Owing to the additional Holweck compression stage it delivers high pumping speed and high compression especially for light gases, and due to its high forevacuum tolerance it is suited for operation in combination with diaphragm or scroll forevacuum pumps.

Housing and Flange Variants

The optimised rotor geometry has been specially adapted to the industrial standard sizes for maximum pump performance. Housings with ISO-K as well as CF flanges are available. Moreover, the standard housings with an additional inlet stage are available upon request

Flexibility

The forevacuum connection for the pump sizes TURBOVAC 90 i / iX - TURBOVAC 450 i / iX is rotatable thereby facilitating flexible installation within existing systems making optimum use of the available space. Moreover, the required amount of installation space may be reduced by a detachable cable connected interface module

TURBOVAC i Multi-Inlet

The variant with a special rotor design and two or more inlets as an efficient and compact vacuum solution for multi-chamber systems. It allows a high degree of system integration and convinces compared to systems with single turbomolecular pumps through its lower weight and smaller footprint. Furthermore the multi-inlet versions offer an increased reliability of the entire vacuum system through the reliance on fewer components compared to similar systems equipped with single turbomolecular pumps.

Multiple inlet stages can be implemented through the **TURBOVAC Multi-Inlet**. Here in addition to the special cartridge solution which facilitates easy replacement in the field, also custom housing and chamber solutions are offered for utmost system integration.



Left: TURBOVAC i with radial forevacuum flange
Right: TURBOVAC i with axial forevacuum flange

Accessories for TURBOVAC i / iX

Power Supply

TURBO.POWER integra

- Plug-and-play power supply for fitting underneath the pump, 100-240 V
 - for TURBOVAC 90 - 450 i / iX only
- Including short connecting cable to the pump
- Also for benchtop placement (TURBOVAC 90 - 450) with optional extension cable (1, 3, 5 m (3.5, 10.5, 17.5 ft))
- Requires a country-specific mains cord (EU, US, UK ...)



Power Supply

TURBO.POWER 800

- Plug-and-play power supply for fitting to the side of the pump, 100-240 V
 - for TURBOVAC 850 / 950 i / iX only

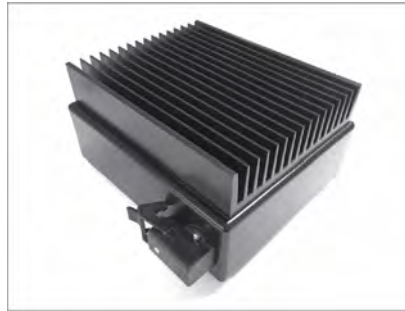

24VDC Display Unit

TURBO.CONTROL i

- Control and monitoring of a TURBOVAC i / iX pump
- The 24 V/DC operating voltage comes from a plug power supply with round plug (24 V/DC - 1.5A - 36W)
- Can be installed in a rack or mounted in a table housing

- Has two communication channels (RS485 & USB) to the pump control and two interfaces for gauges. An ethernet provides the possibility of running a web server for the pump control and monitoring on an external PC and to read logged data via the TURBO.CONTROL i.
- Requires a plug-in power supply and a standard cable for communication
- The following measuring gauges can be attached:
PTR90, PTR90N, TTR91R, TTR91N, TTR101



Pump control unit with Power Supply TURBO.CONTROL 300 for TURBOVAC 90 - 450 i / iX

- Control unit and power supply for rack installation
- With on/off switch for the turbomolecular pump
- Status LEDs and status relays for monitoring the pump
- For remote control via interface
- Requires a connection cable to the pump (1, 3, 5 m (3.5, 10.5, 17.5 ft)) and country-specific mains cord (EU, US, UK ...)

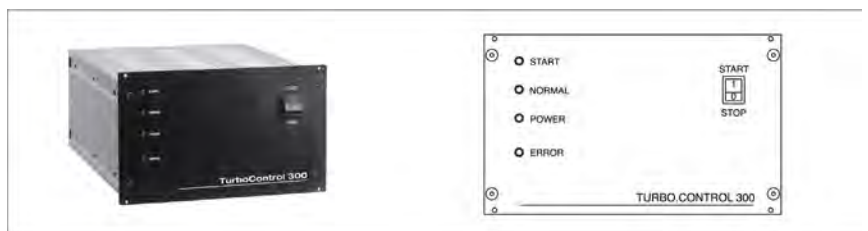

Connecting cables to the pump with bare wire ends of for customer specific power supply units



Relay Box

The relay box allows you to control via the 24 V DC output on the TURBOVAC i a mains powered electric consumer, like a backing pump, for example. Mains power and consumer are connected using mains power cords, the control voltage is connected through an M 8 connector.

- incl. connection cable with a M 8 plug, 2 m (7.0 ft) long



DC pump plug for TURBOVAC 90 - 450 i

for adapting the supply voltage by the customer.

- 24/48 V DC-In plug TURBOVAC i



Radial air cooler

for lateral installation on the pump, including connection plug

- Flexible positioning



Axial air cooler for TURBOVAC 90 - 450 i

For installation underneath the pump, including connection plug



Water cooling

for flexible installation on the pump (required for degassing the turbomolecular pump)



Heating Collar

for degassing the pump

- Degassing temperature 100 °C (212 °F)
- Requires a country-specific mains cord (EU, US, UK ...)
- With optional relay box and accessory cable, automatic control via the electronics of the TURBOVAC i / iX is possible



Accessory Valves

- Power supply 24 V DC
- G 1/8" inlet (inside thread) and discharge (outside thread) connection
- Including O-ring and connecting cable with M 8 plug for connection to the accessory input on the TURBOVAC i / iX

Venting Valve (for connection the venting connection)

for venting the turbomolecular pump

- The valve is normally closed

Power Failure Venting Valve (for connection the venting connection)

for venting the turbomolecular pump

- The valve is normally open

Purge Gas Throttle

for passively controlling the admitted purge gas quantity

- G 1/8" inlet (inside thread) and discharge (outside thread) connection
- Purge gas throttle 24 sccm

Air Filter

for connection to the valves or throttles

- Prevents contamination and clogging of valves and throttles
- G1/8"

Y-Splitter

- Extends the M 8 accessory connection on the TURBOVAC i by a further connection for parallel driving of two accessory components. Here both accessory components are switched synchronously

Purge Gas Valve (for connection to the purge gas connection on the turbomolecular pump)

for controlling the admitted purge gas quantity

- The valve is closed when no power



Installation and Mounting Accessories

Mounting kit for safe mounting of the pump

The mounting kits include:

ISO-K kit (63, 100, 160 and 200):
centering rings and clamps

ISO-F kit (63, 100, 160 and 200):
collar flange, outside ring, bolts and nuts

CF kit (63, 100, 160 and 200):
2 copper gaskets, bolts, nuts and washers



Mounting kits (left ISO-KF, centre ISO-F, right CF)

Centering Rings with Splinter Guard (DN 63, 100, 160 and 200 ISO-K/F)

Centering Rings with Inlet Screens (DN 63, 100, 160 and 200 ISO-K/F)

Splinter Guards (DN 63, 100, 160 and 200 CF)

Inlet Screens (DN 63, 100, 160 and 200 CF)

for protecting the pump against ingesting parts.

Inlet screen, 3.2 mm (0.01 ft) mesh
Splinter guard, 0.8 mm (0.003 ft) mesh

Note:

For ISO-K/F, both inlet screen and splinter guard have been integrated in the centering ring.



Vibration Absorber (DN 100/160 ISO-K and 100/160 CF)

Prevents any possible vibration transfer from the pump to sensitive instrumentation or apparatus.



Software LEYASSIST *

Software platform developed to intuitively control, configure, monitor Leybold vacuum products and intelligent systems through USB or serial RS232 / RS485 to USB interfaces. We are continuously developing LeyAssist to respond to our customer needs and to expand the support of the full range of intelligent Leybold products over time.

Functionality:

- Auto connect to Leybold Vacuum products
- Configure and control products
- Checking alarm warning status and doing trouble shooting
- Easy configuration of intelligent pump systems around local Hub products such as TURBOVAC i / iX
- Enabling Plug & Play

* available as free download from our website



Products

TURBOVAC

with Hybrid Rotor Suspension (mag/mech)

with integrated Frequency Converter

TURBOVAC 90 i, 250 i, 350 i, 450 i, 850 i and 950 i



TURBOVAC i family

with integrated Frequency Converter and

integrated Vacuum System Controller

TURBOVAC 90 iX, 250 iX, 350 iX, 450 iX, 850 iX

and 950 iX



TURBOVAC iX family

Typical Applications

- Analytical technologies / Research & Development
 - Mass spectrometers
 - Electron microscopes
 - Surface analysis
 - X-ray-analysis
 - Particle accelerators and synchrotrons
 - Laboratory coating systems
 - MBE (Molecular Beam Epitaxy)
 - UHV systems
- Life Sciences
 - Proton therapy
 - Gamma sterilisation
 - Production of high quality implants
- Industrial and Coating applications
 - PVD- Physical Vapour deposition
 - Optical coatings
 - CD/DVD/Blu-Ray Disc production
 - Thin film technologies, photovoltaics
 - Wear protection
 - Heat treatment
 - Electron beam welders
- Load locks, transfer chambers, handling systems
- Insulation vacuum and leak detection

Technical Features

TURBOVAC i

- Integrated electronic drive unit with 24/48 V DC supply
- Best in class pumping speed and compression ratio especially for light gases
- Vacuum port design flexibility
- Installation in any orientation
- Superior reliability due to innovative pump and bearing design
- Maintenance free hybrid mechanical TMP
 - no need for oil changes
- On-site maintenance possibility (bearing exchange) to reduce service costs and time
- Widest range of interface options (USB, RS 485 and 15 pin digital I/O as standard)
- Optimized size/performance ratio on 63, 100, 160 and 200 flanges
- Flexible accessory program options for easy plug & play
- Flexibility to match different process and application requirements

TURBOVAC iX

- Same features like TURBOVAC i
- Integrated vacuum system controller with flexible interfaces and several accessory ports for control of cooling units, valves, gauges, forevacuum pumps etc.

Advantages for the User

TURBOVAC i

- Best performance and functionality for your money
- Maximum user flexibility for easy system integration, operation and control
- Highest productivity and system uptime at lowest CoO (Cost of Ownership)
- Improved pump-down time and target pressures
- Superior pumping performance for light gases
- Down-sizing of vacuum system in terms of costs and dimensions (use of small forevacuum pumps)

TURBOVAC iX

- Same advantages like TURBOVAC i
- Easy plug & play pump system control
- Avoid extra costs for separate pump system control units and cabling

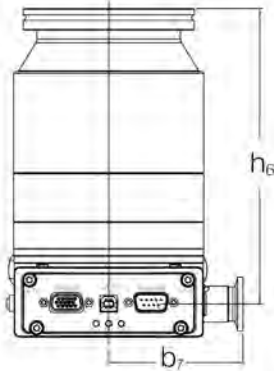
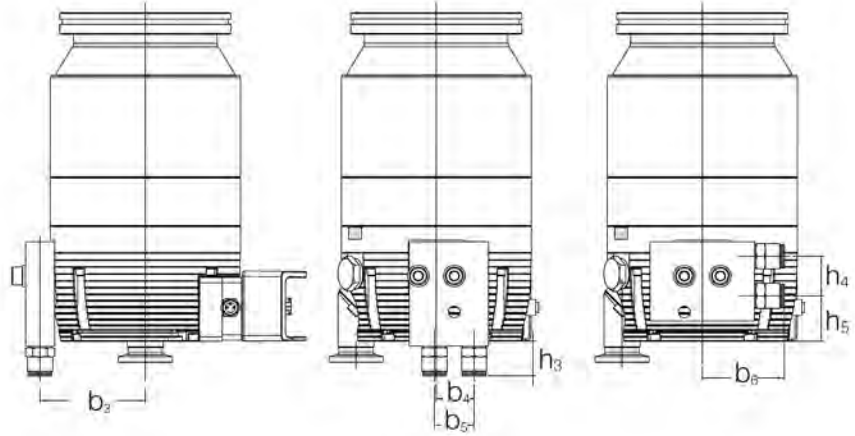
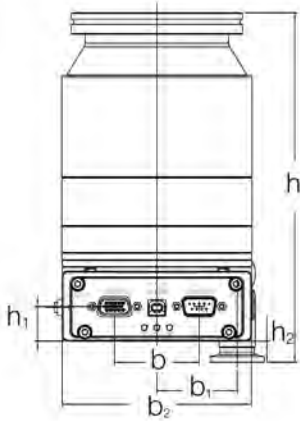

Typ	DN		a	a ₁	b	b ₁	b ₂	b ₃	b ₄
TURBOVAC 90 i	ISO-K	mm (in.)	-	-	47 (1.85)	45 (1.77)	105 (4.13)	58 (2.28)	21 (0.83)
	CF	mm (in.)	-	-	47 (1.85)	45 (1.77)	105 (4.13)	58 (2.28)	21 (0.83)
TURBOVAC 250 i	ISO-K	mm (in.)	49 (1.93)	47 (1.85)	20 (0.79)	75 (2.95)	81 (3.19)	89 (3.50)	47 (1.85)
	CF	mm (in.)	49 (1.93)	-	20 (0.79)	75 (2.95)	81 (3.19)	89 (3.50)	47 (1.85)
		DN	b ₁	b ₂	b ₃	d	d ₁	h	h ₁
TURBOVAC 90 i	ISO-K	mm (in.)	22 (0.87)	46 (1.81)	75 (2.95)	110 (4.33)	-	194 (7.64)	19 (0.75)
	CF	mm (in.)	22 (0.87)	46 (1.81)	75 (2.95)	110 (4.33)	-	194 (7.64)	19 (0.75)
TURBOVAC 250 i	ISO-K	mm (in.)	105 (4.13)	54 (2.13)	57 (2.24)	130 (5.12)	131 (5.16)	196 (7.32)	19 (0.75)
	CF	mm (in.)	105 (4.13)	54 (2.13)	52 (2.05)	151.5 (5.96)	131 (5.16)	205 (8.07)	19 (0.75)
		DN	h ₂	h ₃	h ₄	h ₅	h ₆		
TURBOVAC 90 i	ISO-K	mm (in.)	12 (0.47)	19 (0.75)	22 (0.87)	25 (0.98)	164 (6.46)		
	CF	mm (in.)	12 (0.47)	19 (0.75)	22 (0.87)	25 (0.98)	164 (6.46)		
TURBOVAC 250 i	ISO-K	mm (in.)	36 (1.41)	39 (1.54)	19 (0.75)	38 (1.50)	19 (0.75)		
	CF	mm (in.)	36 (1.41)	39 (1.54)	19 (0.75)	38 (1.50)	19 (0.75)		

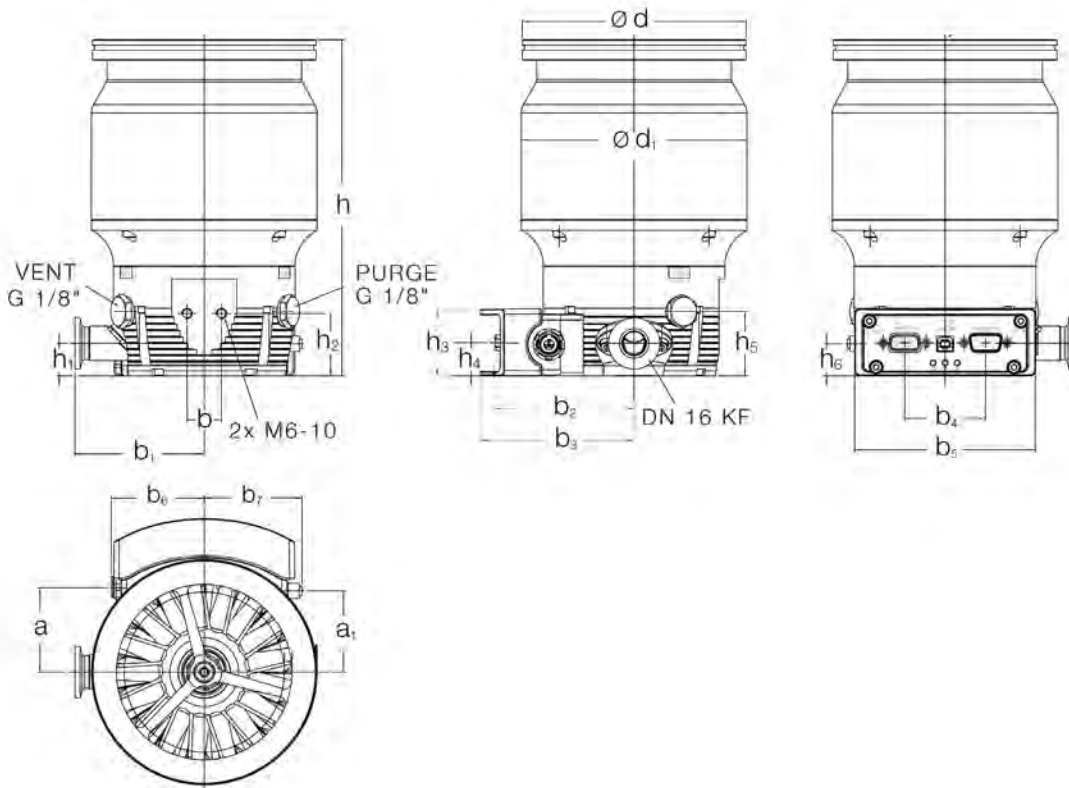

Dimensional drawing for the TURBOVAC pumps, 90 i top and 250 i bottom

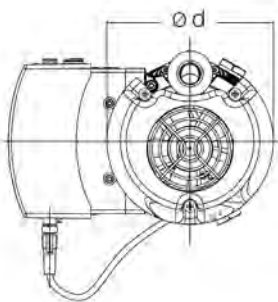
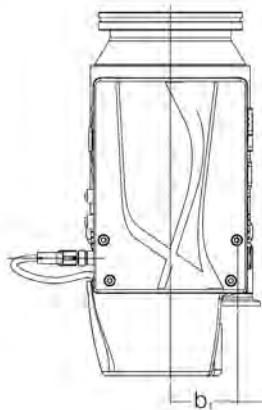
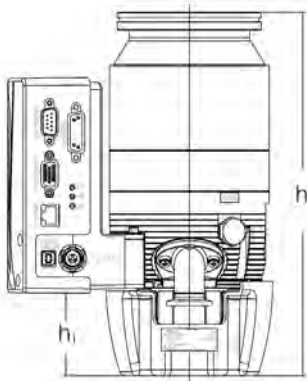

Typ	DN		a	a ₁	a ₂	b	b ₁	b ₂	b ₃
TURBOVAC 90 IX	ISO-K mm (in.)		-	-	-	-	-	45 (1.77)	-
	CF mm (in.)		-	-	-	-	-	45 (1.77)	-
TURBOVAC 250 IX	ISO-K mm (in.)		92 (3.62)	75 (2.95)	93 (3.66)	20 (0.79)	75 (2.95)	120 (4.72)	110 (4.33)
	CF mm (in.)		92 (3.62)	75 (2.95)	93 (3.66)	20 (0.79)	75 (2.95)	120 (4.72)	110 (4.33)
		DN	d	d ₁	h	h ₁	h ₂	h ₃	h ₄
TURBOVAC 90 IX	ISO-K mm (in.)		110 (4.33)	-	240 (9.45)	55 (2.16)	-	-	-
	CF mm (in.)		110 (4.33)	-	240 (9.45)	55 (2.16)	-	-	-
TURBOVAC 250 IX	ISO-K mm (in.)		130 (5.12)	131 (5.16)	196 (7.72)	19 (0.75)	36 (1.42)	199 (7.83)	57 (2.24)
	CF mm (in.)		151.5 (5.96)	131 (5.16)	205 (8.07)	19 (0.75)	36 (1.42)	208 (8.19)	66 (2.60)
		DN	h ₅	h ₆	h ₇	h ₈	h ₉		
TURBOVAC 90 IX	ISO-K mm (in.)		-	-	-	-	-	-	-
	CF mm (in.)		-	-	-	-	-	-	-
TURBOVAC 250 IX	ISO-K mm (in.)		38 (1.50)	64 (2.52)	47 (1.85)	23 (0.91)	23 (0.91)		
	CF mm (in.)		38 (1.50)	64 (2.52)	47 (1.85)	23 (0.91)	23 (0.91)		

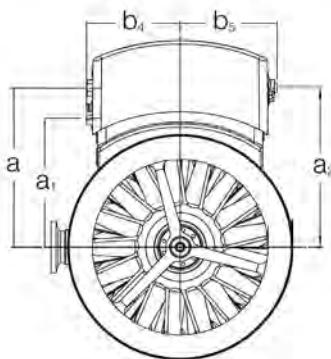
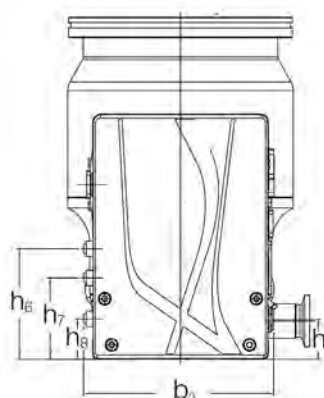
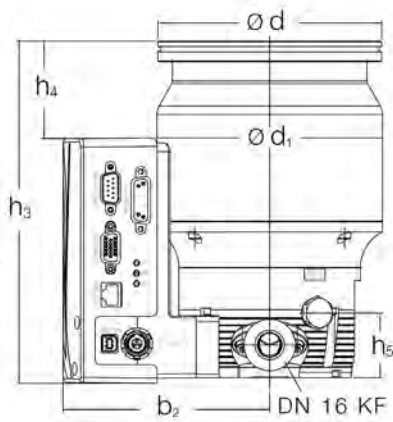
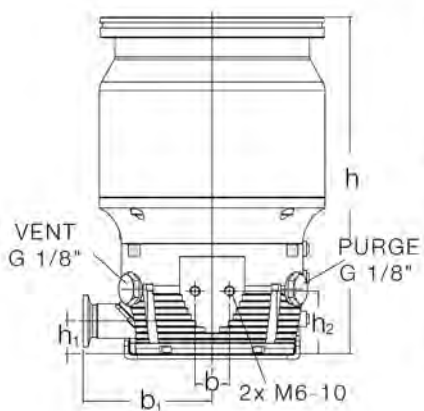

Dimensional drawing for the TURBOVAC pumps, 90 IX top and 250 IX bottom

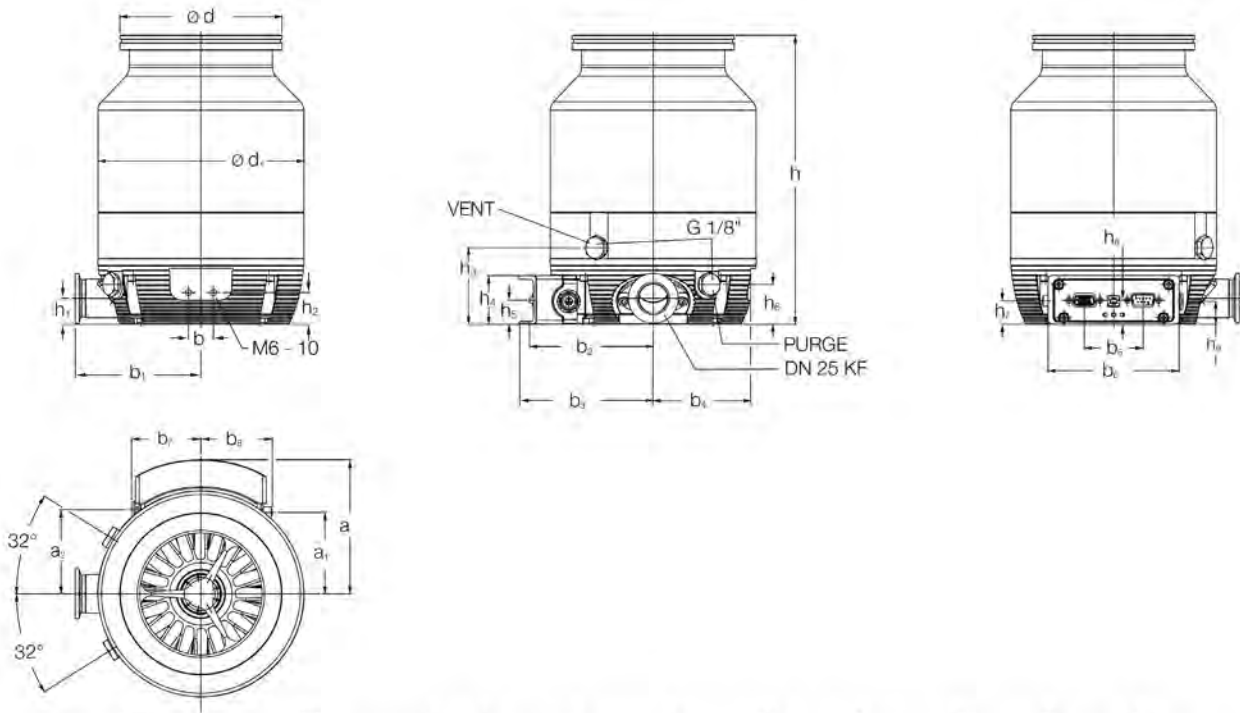

Type	DN		a	a ₁	a ₂	b	b ₁	b ₂	b ₃	b ₄
TURBOVAC 350 i	ISO-K	mm (in.)	107.5 (4.23)	65.4 (2.57)	67.6 (2.66)	20 (0.79)	100.7 (3.96)	99.2 (3.91)	107.5 (4.23)	78.1 (3.07)
	CF	mm (in.)	107.5 (4.23)	65.4 (2.57)	67.6 (2.66)	20 (0.79)	100.7 (3.96)	99.2 (3.91)	107.5 (4.23)	78.1 (3.07)
TURBOVAC 450 i	ISO-K	mm (in.)	107.5 (4.23)	65.4 (2.57)	67.6 (2.66)	20 (0.79)	100.7 (3.96)	99.2 (3.91)	107.5 (4.23)	78.1 (3.07)
	CF	mm (in.)	107.5 (4.23)	65.4 (2.57)	67.6 (2.66)	20 (0.79)	100.7 (3.96)	99.2 (3.91)	107.5 (4.23)	78.1 (3.07)
	DN		b ₅	b ₆	b ₇	b ₈	d	d ₁	h	h ₁
TURBOVAC 350 i	ISO-K	mm (in.)	47 (1.85)	105 (4.13)	55.5 (2.19)	57.2 (2.25)	130 (5.12)	165 (6.5)	232 (9.13)	20.8 (0.82)
	CF	mm (in.)	47 (1.85)	105 (4.13)	55.5 (2.19)	57.2 (2.25)	180 (7.09)	165 (6.5)	245 (9.65)	20.8 (0.82)
TURBOVAC 450 i	ISO-K	mm (in.)	47 (1.85)	105 (4.13)	55.5 (2.19)	57.2 (2.25)	130 (5.12)	165 (6.5)	216 (8.5)	20.8 (0.82)
	CF	mm (in.)	47 (1.85)	105 (4.13)	55.5 (2.19)	57.2 (2.25)	180 (7.09)	165 (6.5)	222 (8.74)	20.8 (0.82)
	DN		h ₂	h ₃	h ₄	h ₅	h ₆	h ₇	h ₈	h ₉
TURBOVAC 350 i	ISO-K	mm (in.)	25.5 (1.0)	61.5 (2.42)	39 (1.54)	19.4 (0.76)	32 (1.26)	19 (0.75)	18.8 (0.74)	18.4 (0.72)
	CF	mm (in.)	25.5 (1.0)	61.5 (2.42)	39 (1.54)	19.4 (0.76)	32 (1.26)	19 (0.75)	18.8 (0.74)	18.4 (0.72)
TURBOVAC 450 i	ISO-K	mm (in.)	25.5 (1.0)	61.5 (2.42)	39 (1.54)	19.4 (0.76)	32 (1.26)	19 (0.75)	18.8 (0.74)	18.4 (0.72)
	CF	mm (in.)	25.5 (1.0)	61.5 (2.42)	39 (1.54)	19.4 (0.76)	32 (1.26)	19 (0.75)	18.8 (0.74)	18.4 (0.72)

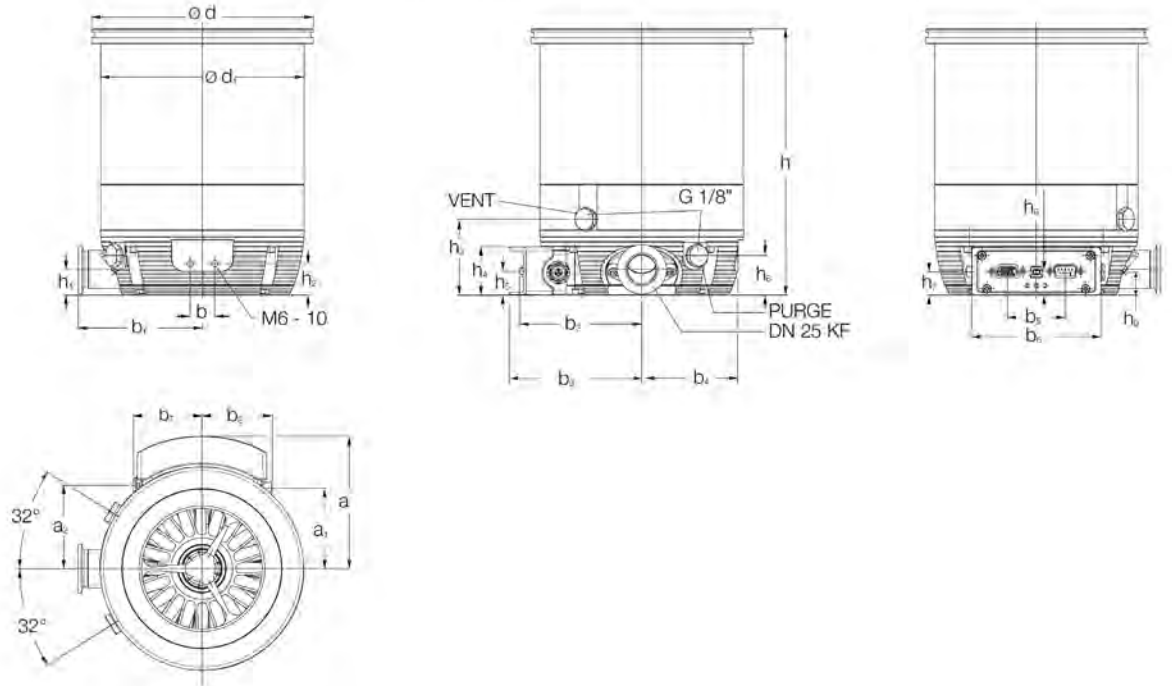

Dimensional drawing for the TURBOVAC pumps, 350 i top and 450 i bottom

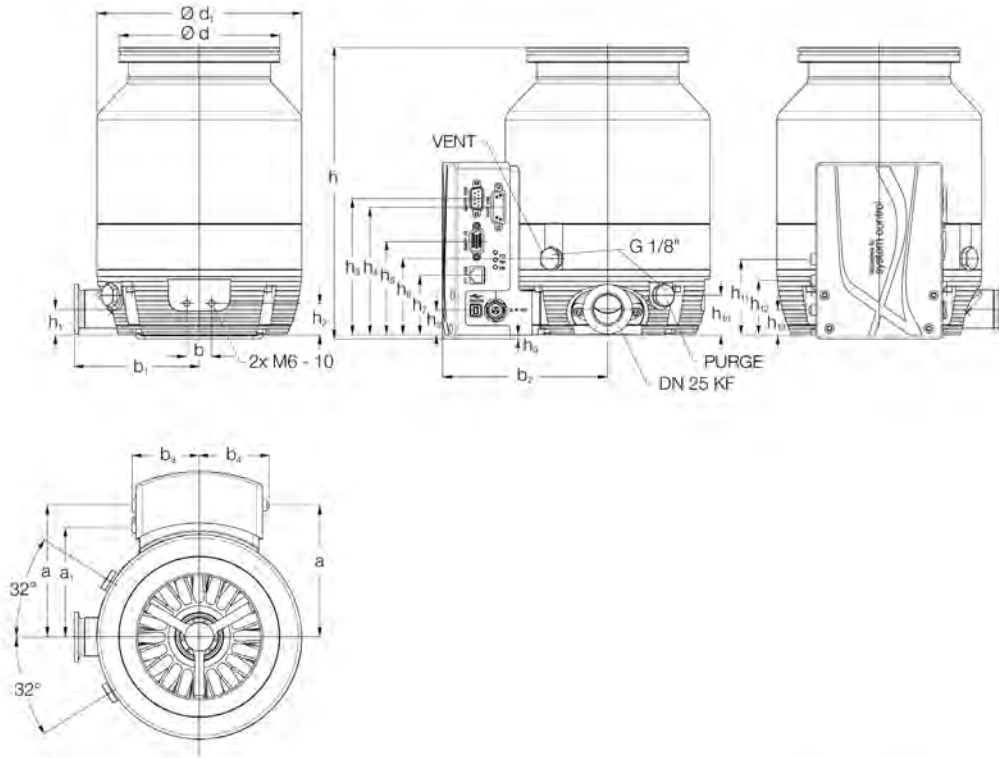

Type	DN		a_1	a_2	t_1	b_1	b_2	b_3	b_4
TURBOVAC 350 IX	ISO-K	mm (in.)	111 (4.37)	78 (3.07)	20 (0.79)	101 (3.98)	138 (5.43)	54 (2.13)	56 (2.2)
	CF	mm (in.)	111 (4.37)	78 (3.07)	20 (0.79)	101 (3.98)	138 (5.43)	54 (2.13)	56 (2.2)
TURBOVAC 450 IX	ISO-K	mm (in.)	111 (4.37)	78 (3.07)	20 (0.79)	101 (3.98)	138 (5.43)	54 (2.13)	56 (2.2)
	CF	mm (in.)	111 (4.37)	78 (3.07)	20 (0.79)	101 (3.98)	138 (5.43)	54 (2.13)	56 (2.2)
	DN		d	d_1	h	h_1	h_2	h_3	h_4
TURBOVAC 350 IX	ISO-K	mm (in.)	130 (5.12)	165 (6.5)	236 (9.29)	21 (0.83)	26 (1.02)	110 (4.33)	103 (4.06)
	CF	mm (in.)	180 (7.09)	165 (6.5)	248 (9.76)	21 (0.83)	26 (1.02)	110 (4.33)	103 (4.06)
TURBOVAC 450 IX	ISO-K	mm (in.)	130 (5.12)	165 (6.5)	219 (8.62)	21 (0.83)	26 (1.02)	110 (4.33)	103 (4.06)
	CF	mm (in.)	180 (7.09)	165 (6.5)	225 (8.86)	21 (0.83)	26 (1.02)	110 (4.33)	103 (4.06)
	DN		h_5	h_6	h_7	h_8	h_9	h_{10}	h_{11}
TURBOVAC 350 IX	ISO-K	mm (in.)	62 (2.44)	48 (1.89)	20 (0.79)	3 (0.12)	32 (1.26)	64 (2.52)	47 (1.85)
	CF	mm (in.)	62 (2.44)	48 (1.89)	20 (0.79)	3 (0.12)	32 (1.26)	64 (2.52)	47 (1.85)
TURBOVAC 450 IX	ISO-K	mm (in.)	62 (2.44)	48 (1.89)	20 (0.79)	3 (0.12)	32 (1.26)	64 (2.52)	47 (1.85)
	CF	mm (in.)	62 (2.44)	48 (1.89)	20 (0.79)	3 (0.12)	32 (1.26)	64 (2.52)	47 (1.85)

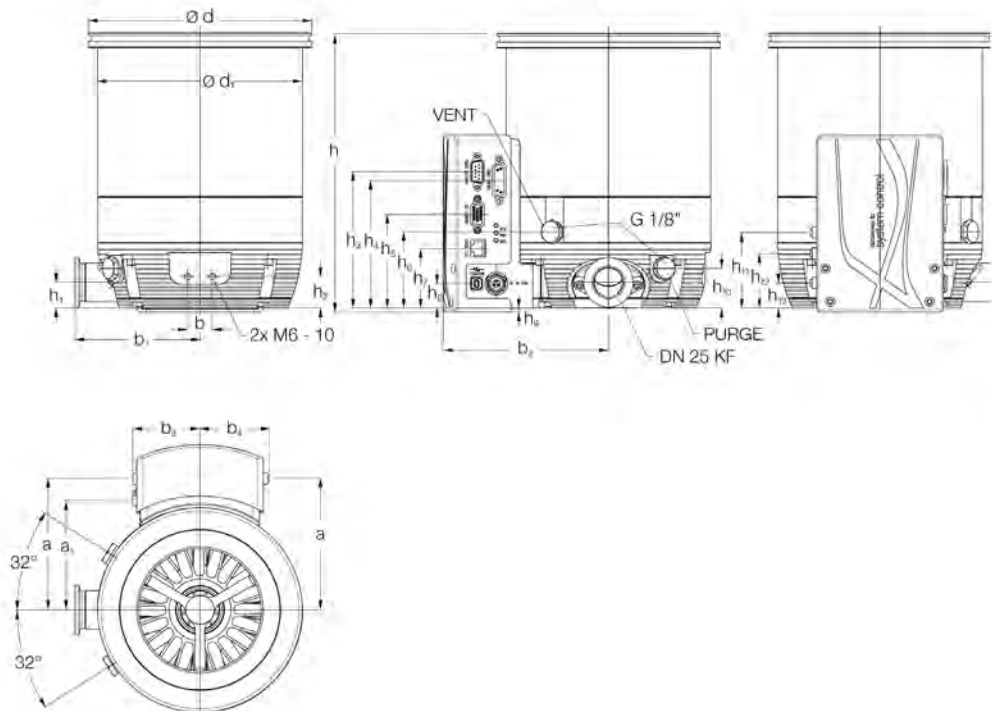

Dimensional drawing for the TURBOVAC pumps, 350 iX top and 450 iX bottom

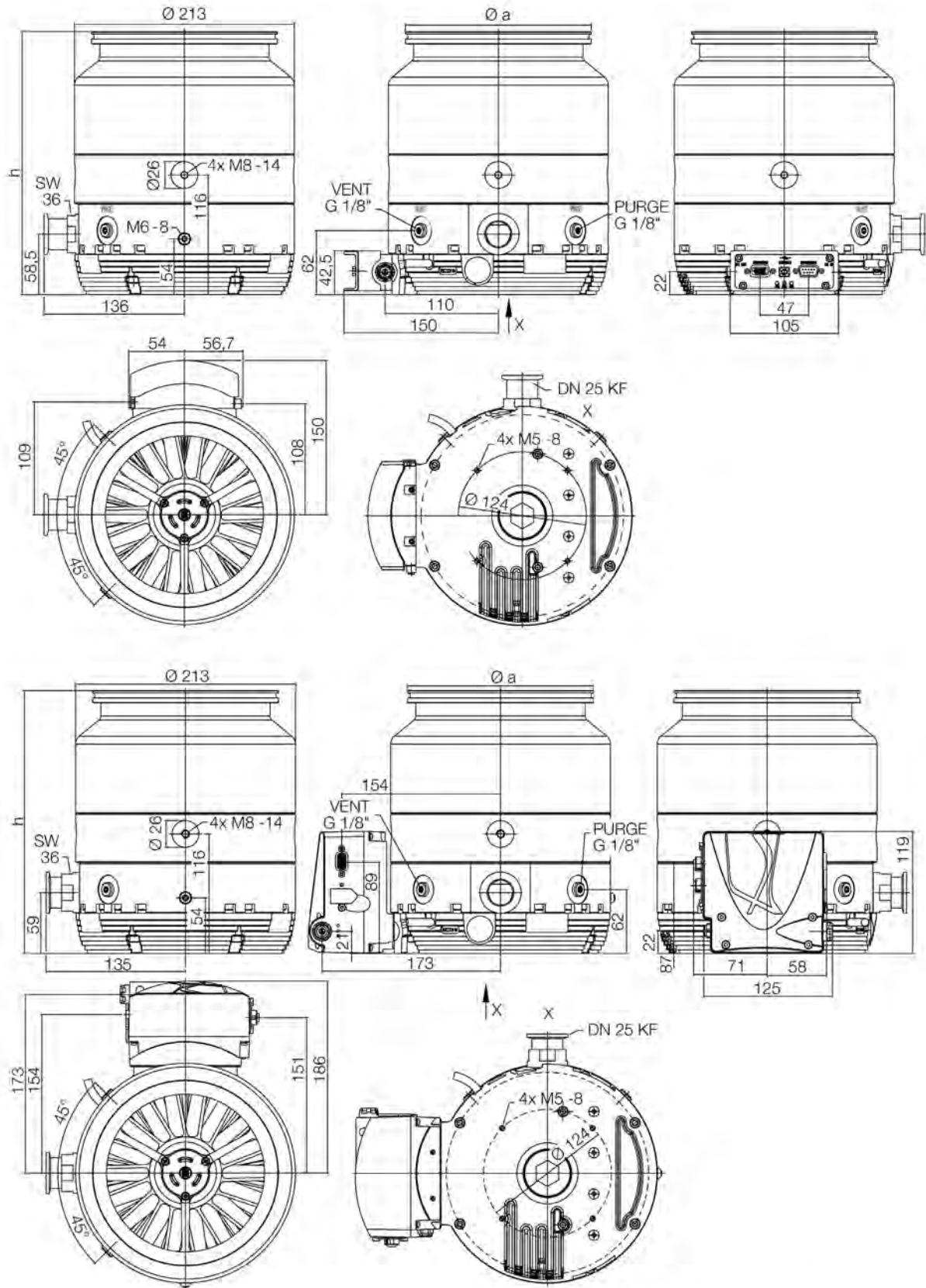

Type	DN		a	h
TURBOVAC 850 i	ISO-K	mm (in.)	180 (7.09)	255 (10.04)
	CF	mm (in.)	202.5 (7.97)	266 (10.47)
TURBOVAC 950 i	ISO-K	mm (in.)	240 (9.45)	250.5 (9.86)
	CF	mm (in.)	254 (10.0)	250.5 (9.86)

Dimensional drawing for the TURBOVAC pumps, 850 i and 950 i

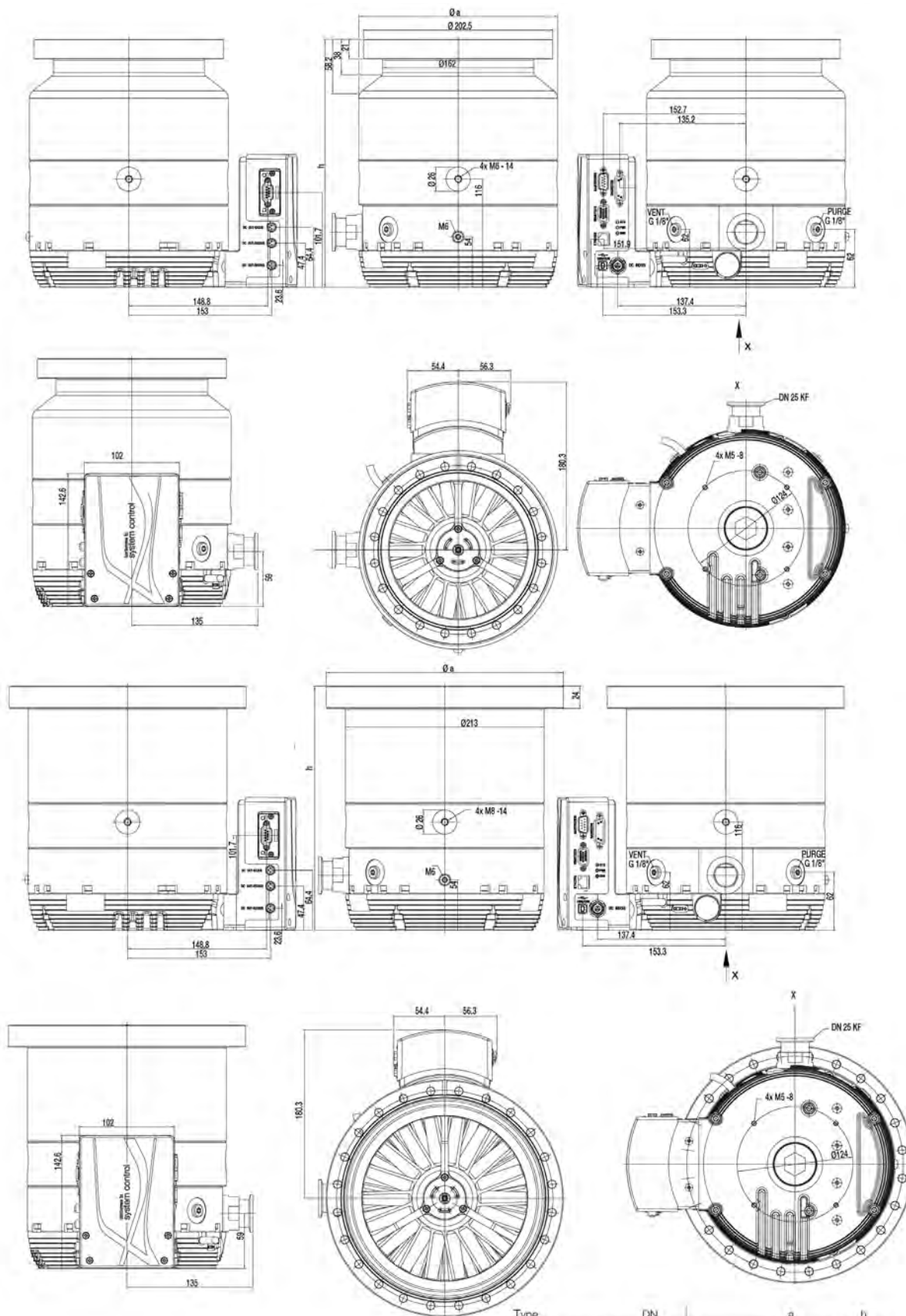

Type	DN		a	h
TURBOVAC 850 iX	ISO-K	mm (in.)	213 (8.39)	254.8 (10.03)
	CF	mm (in.)	213 (8.39)	265.8 (10.46)
TURBOVAC 950 iX	ISO-K	mm (in.)	240 (9.45)	250.3 (9.85)
	CF	mm (in.)	254 (10.0)	261.3 (10.29)

Dimensional drawing for the TURBOVAC pumps, 850 iX and 950 iX

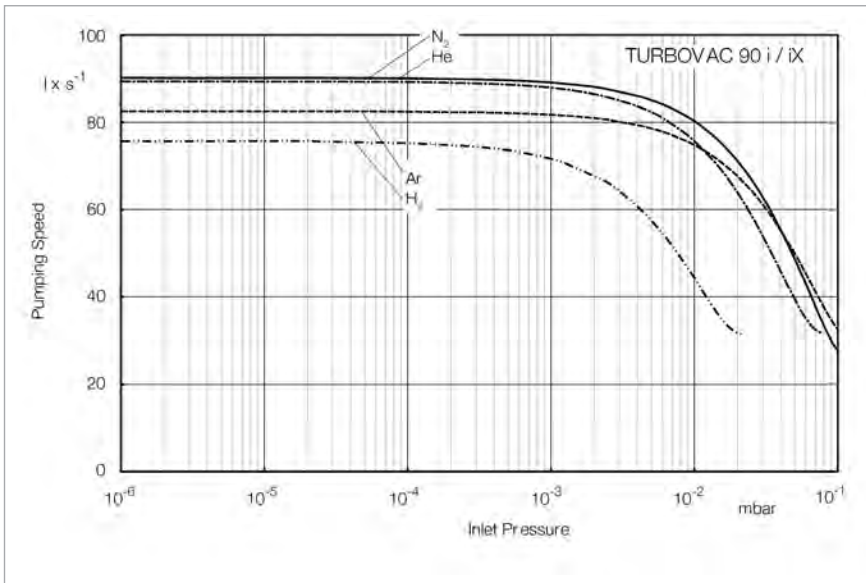

Pumping speed as a function of the inlet pressure for the TURBOVAC 90 i (DN 63 Flange)

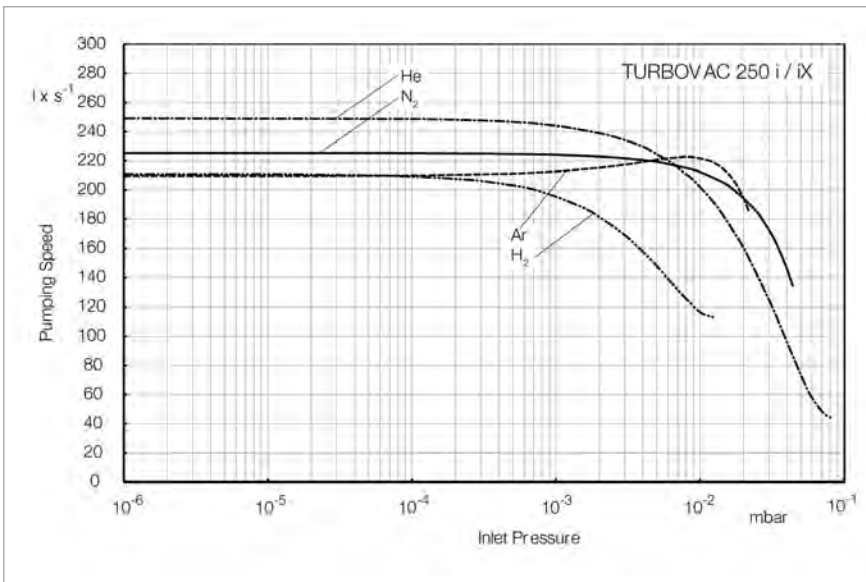

Pumping speed as a function of the inlet pressure for the TURBOVAC 250 i

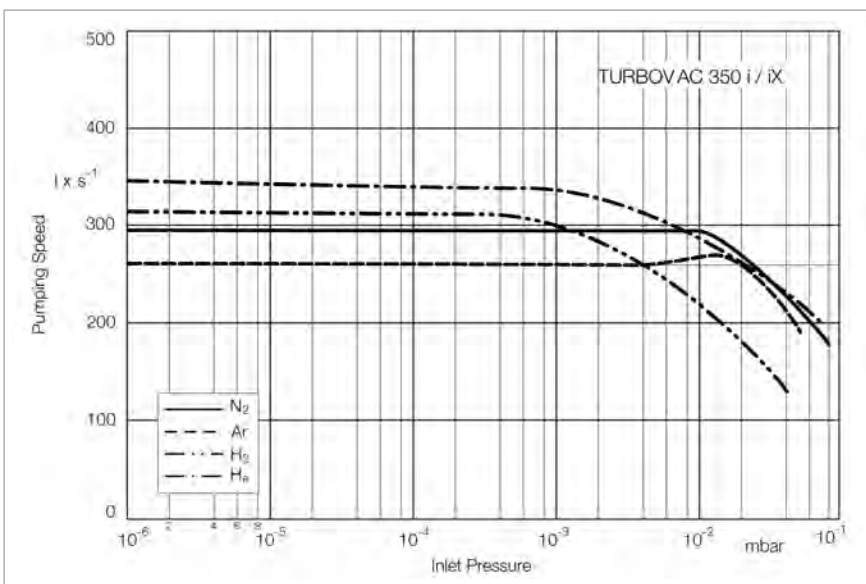

Pumping speed as a function of the inlet pressure for the TURBOVAC 350 i

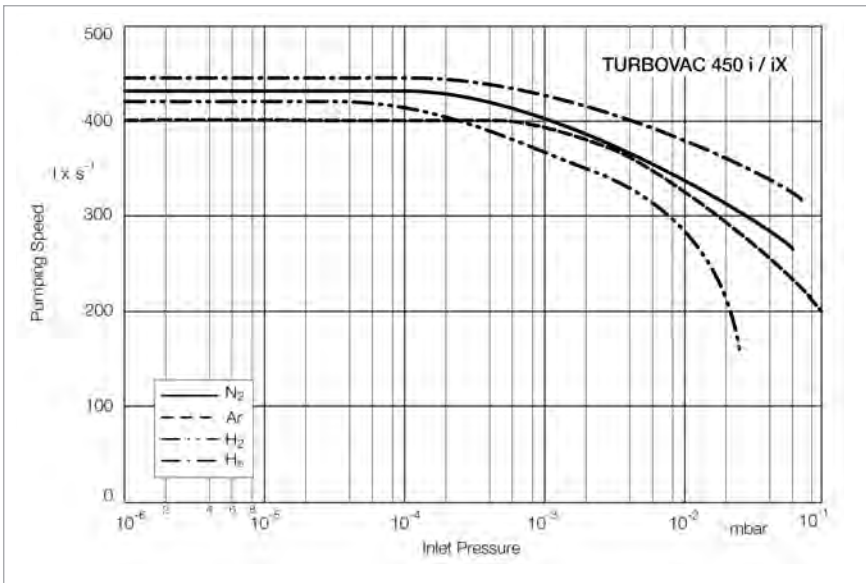

Pumping speed as a function of the inlet pressure for the TURBOVAC 450 i

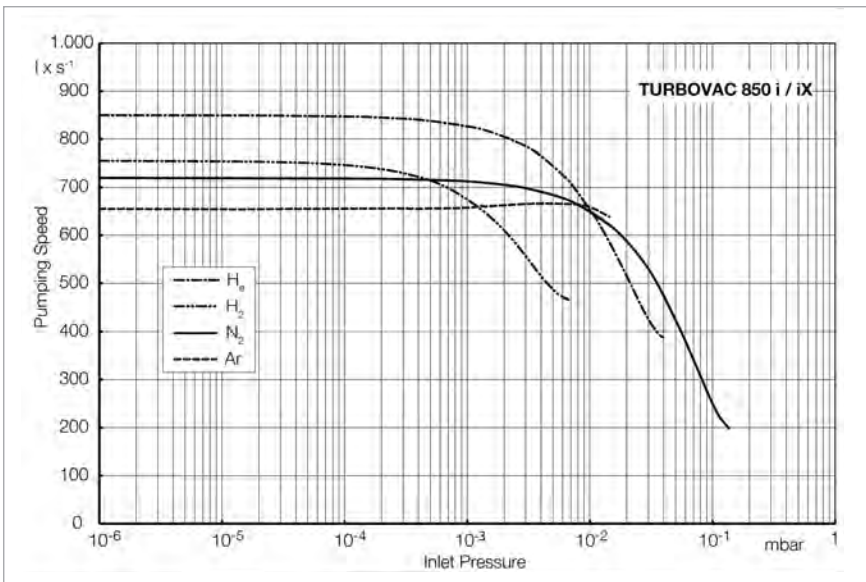

Pumping speed as a function of the inlet pressure for the TURBOVAC 850 i

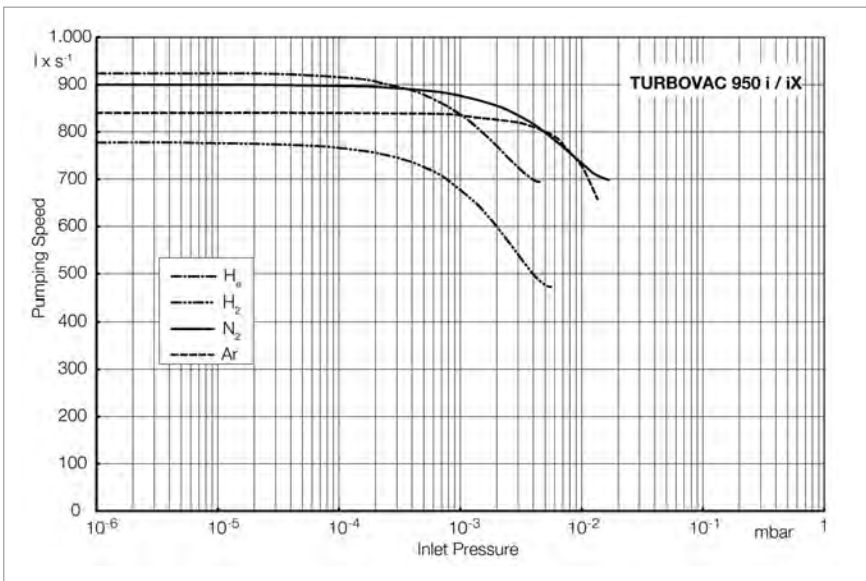

Pumping speed as a function of the inlet pressure for the TURBOVAC 950 i

Technical Data

TURBOVAC

		90 i/iX	250 i/iX	350 i/iX	450 i/iX	850 i/iX	950 i/iX
High vacuum connection	DN	63 ISO-K 63 CF	100 ISO-K 100 CF	100 ISO-K 100 CF	160 ISO-K 160 CF	160 ISO-K 160 CF	200 ISO-K 200 CF
Fore vacuum connection	DN	16 ISO-KF	16 ISO-KF	25 ISO-KF	25 ISO-KF	25 ISO-KF	25 ISO-KF
Pumping speed							
N ₂	l/s	90	225	290	430	720	900
Ar	l/s	83	210	260	400	655	840
He	l/s	90	250	360	440	850	925
H ₂	l/s	78	210	350	420	755	770
Gas throughput							
N ₂	mbar x l/s	10	6	4.5	4.5	14	14
Ar	mbar x l/s	3	3	2	2	3.5	3.5
He	mbar x l/s	11	6	8	8	21	21
H ₂	mbar x l/s	11	>10	8	8	>15	>15
Compression ratio							
N ₂		1 x 10 ¹¹	1 x 10 ¹¹	1 x 10 ¹¹	1 x 10 ¹¹	>1 x 10 ¹¹	>1 x 10 ¹¹
Ar		1 x 10 ¹¹	1 x 10 ¹¹	1 x 10 ¹¹	1 x 10 ¹¹	>1 x 10 ¹¹	>1 x 10 ¹¹
He		-	-	1 x 10 ⁸	1 x 10 ⁸	1.3 x 10 ⁸	1.3 x 10 ⁸
H ₂		5 x 10 ⁷	2 x 10 ⁷	1 x 10 ⁶	1 x 10 ⁶	4.4 x 10 ⁶	4.4 x 10 ⁶
Ultimate pressure with 2-stage oil-sealed rotary vane vacuum pump ISO-K / CF flange			$< 8 \times 10^{-8} / < 5 \times 10^{-10}$ ($< 6 \times 10^{-8} / < 3.8 \times 10^{-10}$)			$< 3.5 \times 10^{-8} / < 6 \times 10^{-10}$ ($< 2.6 \times 10^{-8} / < 4.5 \times 10^{-10}$)	
Max. forevacuum pressure N₂		14 (10.5)	14 (10.5)	10 (7.5)	10 (7.5)	15 (11.3)	15 (11.3)
Recommended forevacuum pumps		TRIVAC SCROLL- VAC plus DIVAC ECODRY plus	D 2,5 E / D 4 B SC 7 plus / 15 plus 3.8 HV3	D 2,5 E / D 4 B SC 7 plus / 15 plus 3.8 HV3	D 4 B SC 7 plus / 15 plus 3.8 HV3	D 4 B SC 7 plus / 15 plus 3.8 HV3 65 plus	D 65 B SC 7 plus / 15 plus 3.8 HV3 65 plus
Operating speed	min ⁻¹ (rpm)	72 000	72 000	60 000	60 000	49 200	49 200
Speed adjustment range	%	62 to 100	62 to 100	50 to 100	50 to 100	61 to 100	61 to 100
Run-up time, approx.	min	1.5	2	5.5	5.5	2.5	2.5
Ambient temperature during operation		+5 to +45 (+41 to +113)	+5 to +45 (+41 to +113)	+5 to +45 (+41 to +113)	+5 to +45 (+41 to +113)	+5 to +45 (+41 to +113)	+5 to +45 (+41 to +113)
during storage		-15 to +70 (+5 to +158)	-15 to +70 (+5 to +158)	-15 to +70 (+5 to +158)	-15 to +70 (+5 to +158)	-15 to +70 (+5 to +158)	-15 to +70 (+5 to +158)
Cooling standard optional		Convection Air or water					
Cooling water connection alternatively		Plug connection for 6 x 1 hose G 1/8" Screw-in thread					
Cooling water consumption	l/h	30 to 60	30 to 60	50 to 100	50 to 100	60	60
Permissible cooling water pressure	bar(g)	3 to 6	3 to 6	3 to 6	3 to 6	6	6
Permissible cooling water temperature	°C (°F)	+15 to +35 (+59 to +95)					
Noise level							
with convection cooling	db(A)	< 41	< 41	< 44	< 44	< 50	< 50
with radial cooler	db(A)	< 44	< 44	< 47	< 47	< 52	< 52
with axial cooler	db(A)	< 49	< 49	< 49	< 49	-	-

**Additional Technical Data for
the Frequency Converter
(i Version)**

TURBOVAC

		90 i	250 i	350 i	450 i	850 i	950 i
Technical Data for the integrated Drive Electronics							
Supply voltage	V DC	24/48 ±10%	24/48 ±10%	24/48 ±10%	24/48 ±10%	48 +5%/-10%	48 +5%/-10%
Max. current consumption	A	10 at 24 V DC	10 at 24 V DC	10 at 24 V DC	10 at 24 V DC	11 at 48 V DC	11 at 48 V DC
Max. power consumption	W	240	240	240	240	600	600
Power consumption at ultimate pressure	W	20	20	20	20	40	40
Type of protection	IP	40					
Interfaces		RS 485, USB, 15-pin digital I/O					
Other interfaces		Upon request					
Accessory connection		1 pcs. M 8 connector, 24 V DC					
Weight ISO-K / CF (pump + frequency converter)	kg (lbs)	3.1 / 4.8 (6.8 / 10.6)	4 / 6.6 (8.8 / 14.5)	7.5 / 11.5 (16.5 / 25.4)	7.7 / 12.5 (17.0 / 27.6)	14.6 / 19.6 (32.2 / 43.2)	15.4 / 21.7 (33.9 / 47.8)

High Vacuum Pumps

**Additional Technical Data for
the Frequency Converter
(iX-Version)**

TURBOVAC

		90 ix	250 ix	350 ix	450 ix	850 ix	950 ix
Technical Data for the integrated Drive Electronics and Vacuum System Controller							
Supply voltage	V DC	24/48 ±10%	24/48 ±10%	24/48 ±10%	24/48 ±10%	48 +5%/-10%	48 +5%/-10%
Max. current consumption	A	10 at 24 V DC	10 at 24 V DC	10 at 24 V DC	10 at 24 V DC	11 at 48 V DC	11 at 48 V DC
Max. power consumption	W	240	240	240	240	600	600
Power consumption at ultimate pressure	W	20	20	20	20	40	40
Type of protection	IP	40					
Interfaces		USB+, 15 pin Standard, Anybus (either RS 485, RS 232, Profibus, ...)					
Accessory connection		3 pcs. M 8 connector, 24 V DC					
Max. load for the 24 V DC output (cooler or valve supply)	V / W	24 / max. 12					
Gauge head connection		15-way Sub-D					
Weight ISO-K / CF (pump + frequency converter)	kg (lbs)	3.6 / 5.3 (7.9 / 11.7)	4,5 / 7.1 (9.9 / 15.6)	8,0 / 12,0 (17.6 / 26.5)	8,2 / 13,0 (18.1 / 28.7)	15,1 / 20,1 (33.3 / 44.3)	15,9 / 22,2 (35.1 / 48.9)

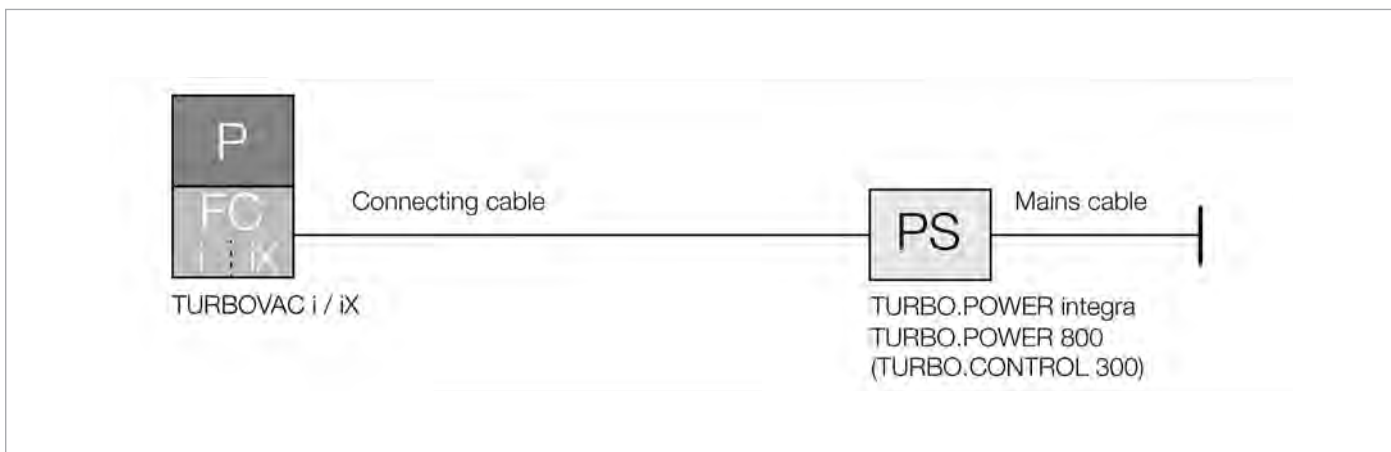

Ordering Information

TURBOVAC

	90 i	250 i	350 i	450 i	850 i	950 i
	Part No.	Part No.	Part No.	Part No.	Part No.	Part No.
TURBOVAC with integrated frequency converter, RS 485, USB+ and 15-Pin digital I/O interface						
DN 40 ISO-K	810011V1000	-	-	-	-	-
DN 63 ISO-K	810031V1000	-	-	-	-	-
DN 63 CF	810041V1000	-	-	-	-	-
DN 100 ISO-K	-	820051V1000	820051V1000	-	-	-
DN 100 CF	-	820061V1000	820061V1000	-	-	-
DN 160 ISO-K	-	-	-	830071V1000	840071V1000	-
DN 160 CF	-	-	-	830081V1000	840081V1000	-
DN 200 ISO-K	-	-	-	-	-	840091V1000
DN 200 CF	-	-	-	-	-	840111V1000
other interfaces	Upon request					

(TURBOVAC i part no's. ...V2000 plus one optional Anybus modul of part no's 410300V09xx)

	90 iX	250 iX	350 iX	450 iX	850 iX	950 iX
	Part No.	Part No.	Part No.	Part No.	Part No.	Part No.
TURBOVAC with integrated frequency converter, and vacuum system controller, RS 485, USB+ and 15-Pin digital I/O interface						
DN 63 ISO-K	810031V3300	-	-	-	-	-
DN 63 CF	810041V3300	-	-	-	-	-
DN 100 ISO-K	-	820051V3300	830051V3300	-	-	-
DN 100 CF	-	820061V3300	830061V3300	-	-	-
DN 160 ISO-K	-	-	-	830071V3300	840071V3300	-
DN 160 CF	-	-	-	830081V3300	840081V3300	-
DN 200 ISO-K	-	-	-	-	-	840091V3300
DN 200 CF	-	-	-	-	-	840111V3300
other interfaces	Upon request					

Included in the Delivery of the Pump

High and forevacuum flanges are protective-capped

The flange mounting components and the inlet screen are not included in the delivery

Ordering Information

TURBOVAC

90 i / iX 250 i / iX 350 i / iX 450 i / iX 850 i / iX 950 i / iX

Mandatory Accessories	P	PS	Part No.
Power supply TURBO.POWER integra, including 0.3 m (0.98 ft) long cable			800100V0003
Power supply TURBO.POWER 800, including 0.3 m (0.98 ft) long cable			-
Cable pump – TURBO.POWER integra			
1 m (3.3 ft)			800096V0100
3 m (9.8 ft)			800096V0300
5 m (16.4 ft)			800096V0500
Mounting kit TPi on TVi90/250			800100V0005
Mounting kit TURBOVAC			
DN 63 ISO-K			800134V0010
DN 100 ISO-K			800134V0020
DN 160 ISO-K			800134V0030
DN 100 ISO-K to ISO-F			800134V0025
DN 160 ISO-K to ISO-F			800134V0035
DN 200 ISO-K to ISO-F			Upon request
DN 63 CF			800134V0011
DN 100 CF			800134V0021
DN 160 CF			800134V0031
DN 200 CF			Upon request

Forevacuum pumps TRIVAC see Catalog Part “Oil Sealed Vacuum Pumps”

Forevacuum pumps SCROLLVAC plus, ECODRY plus and DIVAC see Catalog Part “Dry Compressing Vacuum Pumps”

Ordering Information

TURBOVAC

90 i / iX 250 i / iX 350 i / iX 450 i / iX 850 i / iX 950 i / iX

Accessories, optional <input type="checkbox"/>	Part No.			
Power supply, cable, other accessories				
24VDC display unit TURBO.CONTROL i	800100V0004			
Standard cable for communication – TURBO.CONTROL i				
USB cable 2.0 Type A/B, 1.8 m (5.9 ft)	800110V0108			
RS485 cable, 5 m (16.4 ft)	800103V0029			
RS485 cable, 1 m (3.3 ft)	800103V0027			
Power supply and control unit TURBO.CONTROL 300	800100V0001	-		
Cable pump – TURBO.CONTROL 300				
1 m (3.3 ft)	800092V0100	-		
3 m (9.8 ft)	800092V0300	-		
5 m (16.4 ft)	800092V0500	-		
Extension cable - only in combination with connecting cable 1m (3.3 ft)				
10 m (33 ft)	80009 2V1000			
20 m (66 ft)	800092V2000			
24/48 V DC In plug TURBOVAC	800090V0000	-		
USB-Kabel 2.0, Type A/B, 1.8 m (5.9 ft) long	800110V0108			
Y cable M 8	800110V0020			
Accessory cable TURBOVAC i, M8 - M8, 2 m	800110V0016			
Relaybox for forevacuum pump, 1-phase, 10 A	800110V0030			
Start stop switch	800110V0021			
Interface modules				
Anybus RS232	410300V0902			
Anybus RS485	410300V0903			
Anybus Profibus M40	410300V0904			
Anybus Profinet IRT	410300V0905			
Anybus Ethernet	410300V0906			
Anybus Ethercat	410300V0907			
IP 54 Anybus Profibus M40	-	410300V0908		
IP 54 Anybus Profinet IRT	-	410300V0909		
IP 54 Anybus Ethernet	-	410300V0910		
IP 54 Anybus Ethercat	-	410300V0911		
Cooling				
Air cooler radial	800136V0007	800136V0009	800136V0005	800136V0011
axial	800136V0008	800136V0008	800136V0006	-
Water cooling, connection thread G 1/8"	800135V0005			800135V0007
Water cooling, connection thread G 1/4"	800135V0006			-

Ordering Information

TURBOVAC

90 i / iX 250 i / iX 350 i / iX 450 i / iX 850 i / iX 950 i / iX

Accessories, optional	P	Part No.
Heating		
Flange heater (needs mains cable, see above) DN 63 CF, 230 V		800137V0003
DN 63 CF, 115 V		800137V0004
DN 100 CF, 230 V		800137V0005
DN 100 CF, 115 V		800137V0006
DN 160 CF, 230 V		800137V0007
DN 160 CF, 115 V		800137V0008
DN 200 CF, 230 V		Upon request
DN 200 CF, 115 V		Upon request
Installation		
Vibration absorber DN 100 ISO-K		800131V1100
DN 160 ISO-K		500073
DN 100 CF		500071
DN 160 CF		500072
Centering ring with fine inlet screen, 0.8 mm (0.03") mesh DN 63 ISO-K/F		800133V0012
DN 100 ISO-K/F		800133V0022
DN 160 ISO-K/F		800133V0032
DN 200 ISO-K/F		800133V0042
with coarse inlet screen, 3.2 mm (0.01") mesh DN 63 ISO-K/F		800133V0011
DN 100 ISO-K/F		800133V0021
DN 160 ISO-K/F		800133V0031
DN 200 ISO-K/F		800133V0041
Fine Inlet screen, 0.8 mm (0.03") mesh DN 63 CF		800132V0012
DN 100 CF		800132V0022
DN 160 CF		800132V0032
DN 200 CF		Upon request
Coarse inlet screen, 3.2 mm (0.01") mesh DN 63 CF		800132V0011
DN 100 CF		800132V0021
DN 160 CF		800132V0031
DN 200 CF		Upon request

Special Turbomolecular Pumps



TURBOVAC i Multi Inlet Cartridge

Precision is key when it comes to analytical instruments.

Outfitted with two or more inlets, the innovative turbopumps with integrated drive electronics provide extraordinary pumping performance and are adaptable to the system requirements of each instrument.

In combination with our support for the whole vacuum system design, it will result in the best possible level of pump system integration you have ever experienced.



For example the TURBOVAC 350-400 i Multi Inlet line has been especially developed to meet the requirements of analytical instruments and features an extremely high level of flexibility, allowing you to choose the number, height and position of the multiple vacuum ports. The result: a pump that is perfectly fitted to your specific performance needs and installation requirements.

Additionally, we offer the support and experience in vacuum system design which opens a wide range of possibilities, from the adaptation of the pump housing to your vacuum chamber through to the design of a custom-built housing/chamber that meets your particular needs. Your benefit: optimum system integration of the pump(s) into your instrument and a reduced time to market.

Your Advantage

- Perfect integration of the pump(s) within your instrumentation
- Cutting of system costs
- Smaller size of the analytical system
- Reduction in the number of individual vacuum components
- Choice between cartridge and custom pump housing

In order to simplify installation, operation and control, all TURBOVAC i variants feature an integrated electronic drive with 24/48 V DC supply and a detachable operator interface with USB, RS 485 and digital I/O connections.

Performance

- Industry-leading pumping speed especially for light gases (up to 60 % higher than existing products)
- Optimized rotor diameter to provide maximum pumping performance
- > 40 l/s pumping speed at Interstage port 2

Flexibility

- Vacuum port design flexibility
 - Rotatable fore-vacuum port
 - Multiple interstage ports
 - High level of flexibility in terms of height and position of vacuum ports
- Unique cartridge solutions for optimized system integration with fast and simple field replacement
- Special pump housing solutions adapted to your instrument
- Complete vacuum system design including your vacuum chamber
- Variable rotor and Holweck design to adapt the performance to your application

Installation, operation and control

- Integrated 24/48 V DC drive electronics to avoid expensive cabling
- Widest range of communication interfaces: USB, RS 485 and remote 15 pin digital I/O as standard options
- Highly efficient motor
- Thermal isolation by design for optimized cooling of bearing and improved pump lifetime
- Simply-supported shaft reduces vibration
- Maintenance free upper passive magnetic bearing
- Oil free, lifetime lubricated lower mechanical ceramic ball bearing, field-replaceable

Outstanding performance

Thanks to its variable rotor and drag stage design, our new Multi Inlet product line provides the highest performance for all mass spectrometer applications. With increased pumping speed levels especially for light gases which are up to 60% higher than those

offered by other products currently on the market, it provides significant advantages for your instruments: lower pressures, improved detection sensitivity levels and higher sample throughput rates.

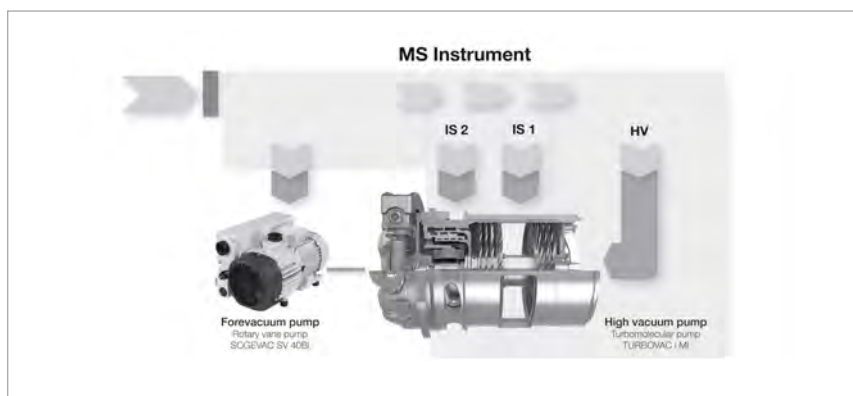

Superior reliability

The unique maintenance and oil free hybrid bearing system is characterized by its extreme reliability and durability – that's because we equipped it with an innovative lifetime lubrication system that never needs an oil change. The simply-supported shaft system results in a low vibration pump design which reduces noise, mechanical stress and negative impact on vibration sensitive applications. Optimized cooling

of the bearings is ensured through thermal isolation and the highly efficient motor. To protect the bearings from critical gases or particles, all pumps are equipped with a purge port. As a consequence, not only pump lifetime is increased significantly, but also system uptime as well as productivity. In combination with low costs of ownership, the operation of your vacuum system will be more efficient than ever.

Advantages to the User

- High gas throughput
- High effective pumping speed
- High efficiency for analytical instruments
- High detection sensitivity
- High sample throughput
- Free of hydrocarbons
- Hybrid bearing suspension for low vibration levels
- Space and weight saving
- Low component count
- Favourable price-to-performance ratio
- Installation and user friendly
- Practically maintenance free

Typical Applications

For example

- LC-MS (linking of a liquid chromatograph to a mass spectrometer)
- GC/MS (linking of a gas chromatograph to a mass spectrometer)
- TOF-MS (time-of-flight mass spectrometer)
- ICP-MS (inductively coupled plasma mass spectrometry)
- Helium leak detectors

Technical Features for this example

- Dual Inlet (pumping down of two analysis chambers)
- Triple inlet (pumping down of three analysis chambers)
- High effective pumping speed
 HV stage up to 400 l/s
 Interstage IS 1 up to 300 l/s
 Interstage IS 2 up to 50 l/s
- Cartridge solutions (without pump housing) are available
- Compact vacuum system

Customized versions are available upon request

Mechanical Rotor Suspension with Frequency Converter for Attaching or Separate with or without Compound Stage TURBOVAC SL 80 / SL 80 H / SL 80 C



Typical Applications

- Mass spectrometers specifically suitable for portable mass spec applications (e.g. suitcase, gas chromatography (GC-MS), liquid chromatography (LC-MS), residual gas analysis, mobile analytical systems, etc.)
- Helium leak detectors
- Electron beam microscopy
- XHV-/UHV systems
- Transfer chambers

Technical Features

- Excellent resistance against vibration and external mechanical shocks - unique mature double mechanical bearing
- Flexible attachment of the frequency converter to the pump
- Small footprint
- Oil-free pump
- High pressure foreline tolerance
- Efficient convection cooling due to a large number of cooling fins
- Purge gas/venting connection
- Installation in any orientation
- Selection of interfaces, USB, RS 232 C, RS 485 C, Profibus

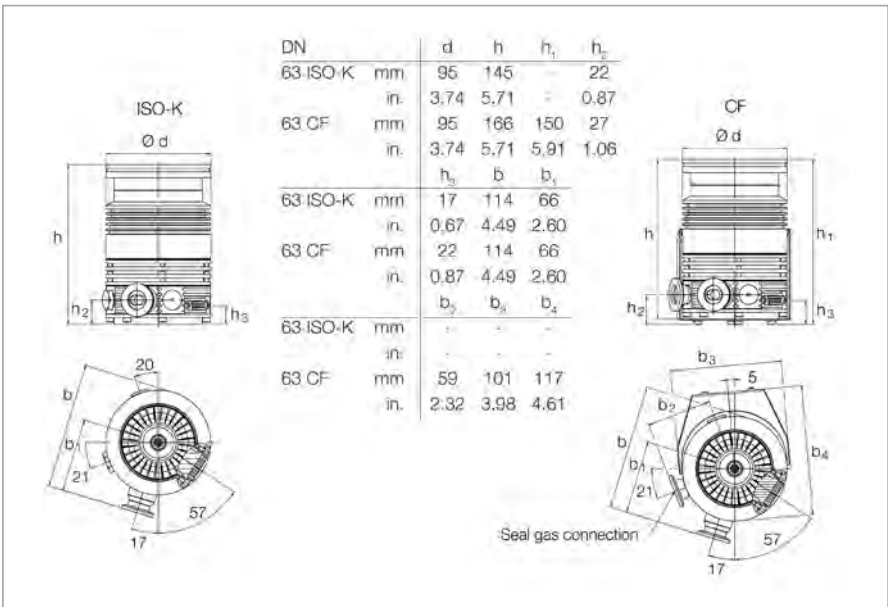

Dimensional drawing for the TURBOVAC SL 80: attachment examples

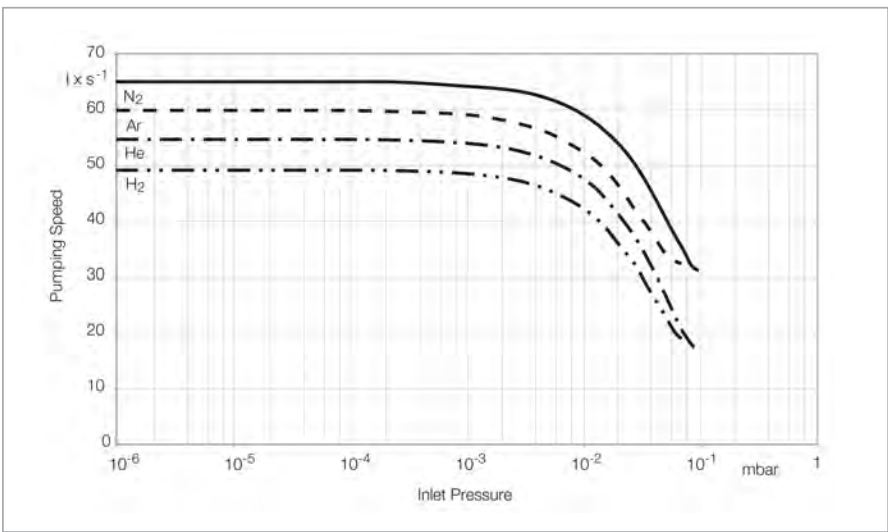

Pumping speed as a function of the inlet pressure

Advantages to the User

- Easy to integrate into complex vacuum systems, especially when space is limited
- Space-saving
- Prepared for pumping of slightly corrosive gases owing to the seal gas connection
- High reliability
MTTF over 200,000 hours
- Matching accessories (fan, water cooling, seal gas/venting valves, power failure venting valves, flange heaters, different cable lengths etc.)

Technical Data

TURBOVAC

		SL 80			SL 80 H		SL 80 C
Connection							
Inlet	DN	40 ISO-KF	63 ISO-K	63 CF	63 ISO-K	63 CF	63 ISO-K
Outlet	DN		16 ISO-KF		16 ISO-KF		16 ISO-KF
Pumping speed							
N ₂	l x s ⁻¹	40	65	65	65		70
Ar	l x s ⁻¹	34	60	60	60		65
He	l x s ⁻¹	44	55	55	55		50
H ₂	l x s ⁻¹	40	49	49	49		45
Gas throughput							
N ₂	mbar · l x s ⁻¹		2.0		0.9		3.5
Ar	mbar · l x s ⁻¹		1.6		0.8		3.5
He	mbar · l x s ⁻¹		1.2		1.5		2.0
H ₂	mbar · l x s ⁻¹		0.5		0.6		1.0
Compression ratio							
N ₂			> 1 x 10 ¹¹		> 1 x 10 ¹¹		2 x 10 ⁶
Ar			> 1 x 10 ¹¹		> 1 x 10 ¹¹		2 x 10 ⁶
He			2 x 10 ⁶		2 x 10 ⁶		6 x 10 ²
H ₂			4 x 10 ⁴		4 x 10 ⁴		2 x 10 ²
Ultimate pressure	mbar Torr)		< 2 x 10 ⁻¹⁰ (< 1.5 x 10 ⁻¹⁰)		< 2 x 10 ⁻¹⁰ (< 1.5 x 10 ⁻¹⁰)		< 5 x 10 ⁻⁸ (< 4.0 x 10 ⁻⁸)
Max. foreline pressure for N ₂	mbar (Torr)		16 (12)		16 (12)		0.35 (0.26)
Recommended forevacuum pump			TRIVAC D 2,5 E / D 4 B SCROLLVAC SC 7 plus / 15 plus DIVAC 1.4 HV3		TRIVAC D 2,5 E / D 4 B SCROLLVAC SC 7 plus / 15 plus DIVAC 1.4 HV3		TRIVAC D 2,5 E / D 4 B SCROLLVAC SC 7 plus / 15 plus -
Nominal rotation speed	min ⁻¹ (rpm)		72 000		72 000		72 000
Run-up time, approx.	min		1.5		1.5		1.5
Max. power consumption	W		120		120		120
Power consumption at ultimate pressure	W		17		17		17
Admissible ambient temperature	°C (°F)		+15 to +45 (+50 to +113)		+15 to +45 (+50 to +113)		+15 to +45 (+50 to +113)
Cooling standard optional			Convection Water / Air		Convection Water / Air		Convection Water / Air
Cooling water connection			G 1/8", inside thread / 8 mm hose nozzle		G 1/8", inside thread / 8 mm hose nozzle		G 1/8", inside thread / 8 mm hose nozzle
Cooling water consumption	l x h ⁻¹		15 to 60		15 to 60		15 to 60
Permissible cooling water pressure	bar		2 to 7		2 to 7		2 to 7
Permissible cooling water temperature	°C (°F)		10 to 40 (50 to 104)		10 to 40 (50 to 104)		10 to 40 (50 to 104)
Weight, approx.	kg (lbs)		1.8 (3.97)	1.9 (4.19)	3.1 (6.84)		1.9 (4.19)



Technical Data

TURBO.DRIVE TD 400

Mains connection	V DC	24
Max. current consumption	A	8
Max. power consumption	W	190
Max. output voltage	V	3 X 24
Interface		USB, RS 232 C, RS 485 C or Profibus
Protection rating	IP	20
Admissible ambient temperature	°C (°F)	+5 to +45 (+41 to +113)
Dimensions (W x H x D)	mm (in.)	100 x 90 x 100 (3.9 x 3.5 x 3.9)
Weight, approx.	kg (lbs)	0.7 (1.6)

Ordering Information

TURBOVAC SL 80 / SL 80 H / SL 80 C

TURBOVAC SL 80	P	Part No.		
with compound stage DN 40 ISO-KF DN 63 ISO-K / DN 16 ISO-KF DN 63 ISO-K / DN 16 ISO-KF (SL 80 H) DN 63 CF / DN 16 ISO-KF DN 63 CF / DN 16 ISO-KF (SL 80 H) without compound stage DN 63 ISO-K / DN 16 ISO-KF (SL 80 C)		800002V3004 800002V3001 800002V3005 800002V3002 800002V3006 800002V3008		
Mandatory Accessories		P	FC	PS
Electronic frequency converter TURBO.DRIVE TD 400 with USB interface with RS 232 C interface with RS 485 C interface with Profibus		800073V0008 800073V0002 800073V0003 800073V0004		
Connecting cable pump - frequency converter 00.2 m (0.66 ft) 00.3 m (0.98 ft) 00.4 m (1.31 ft) 00.5 m (1.64 ft) 01.0 m (3.3 ft) 02.5 m (8.2 ft) 03.0 m (9.84 ft) 05,0 m (16.4 ft) 10.0 m (33.0 ft)		800152V0021 800152V0023 800152V0022 800152V0050 152 47 864 49 864 40 864 50 800080V1000		
Power supply and control unit TURBO.CONTROL 300 24 V connecting cable power supply - TURBO.CONTROL 300 01 m (3.3 ft) 03 m (9.84 ft) 05 m (16.4 ft) 10 m (33.0 ft) 20 m (66.0 ft)		800100V0001 800091V0100 800091V0300 800091V0500 800091V1000 800091V2000		
Power supply TURBO.POWER Integra 24 V connecting cable power supply - TURBO.POWER Integra to TD400 0.5 m (1.64 ft) 05 m (16.4 ft)		800100V0003 800103V0021 800103V0023		
Mains cable 3 m (9.84 ft) - TURBO.CONTROL 300 with EURO plug with UK plu with US plug 5-15 P with US plug 115 V AC, 2 m (6.6 ft)		800102V0002 800102V0003 800102V1002 992 76 513		
START/STOP switch for manual operation of the turbomolecular pump		152 48		

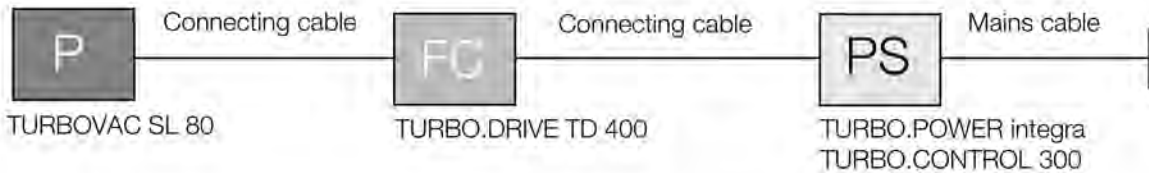

Ordering Information

TURBOVAC SL 80 / SL 80 H / SL 80 C

Accessories, optional	P	FC	PS	Part No.
Mounting kit TD 400 for SL 80, incl. 0.2 m (0.7 ft.) long connecting cable pump - frequency converter for installing the frequency converter beside the pump for installing the frequency converter beneath the pump (not for 800073V0007)	P	FC	PS	800110V0005 800110V0008
Water cooling unit with 2x G 1/8" connections, including 2 hose nozzles G 1/8" 8 mm (0.3 in.) OD, 2 gaskets (copper) 10 x 14 x 1 mm (0.4 x 0.6 x 0.04 in.) and hose clamps				800135V0001
Air cooling unit				800136V0001
Flange heater DN 63 CF, 230 V, 50 Hz DN 63 CF, 115 V, 60 Hz				800137V0003 800137V0004
Fine filter with centering ring DN 40 ISO-KF DN 63 ISO-K (coarse) DN 63 CF (coarse)				E 200 17 169 E 200 17 170 E 200 17 171
Fine filter with centering ring DN 63 ISO-K				887 20
Vibration absorber DN 63 ISO-K DN 63 CF				800131V0063 500 070
Pump connection adapter DN 10 ISO-KF / pump connection M 8 (incl. O-ring, filter and clamping ring)				800110V0011
Purge gas and venting valve gas flow at 1 bar 0.4 mbar x l x s-1 (24 sccm), pump connection DN 10 ISO-KF / gas connection G 1/4" 100 - 115 V AC 24 V DC				800152V0042 800152V0013
Gas filter to G 1/4" for purge gas and venting valve				800110V0012
Replacement filter				E 200 18 515
Power failure venting valve, normally open 24 V DC, DN 16 ISO-KF				800120V0021
Power failure venting valve, normally open 024 V DC, DN 10 ISO-KF 230 V AC / 50/60 Hz, DN 10 ISO-KF				174 46 174 26
Hat rail adaptor as mounting aid				800110V0003
Fin type cooler				800110V0001

TURBOVAC MAG iS – Magnetic Rotor Suspension with integrated Frequency Converter, with Drag Stage TURBOVAC MAG 2207 iS to 3207 iS



Figure 8. Dimension drawing - MAG 2207 iS

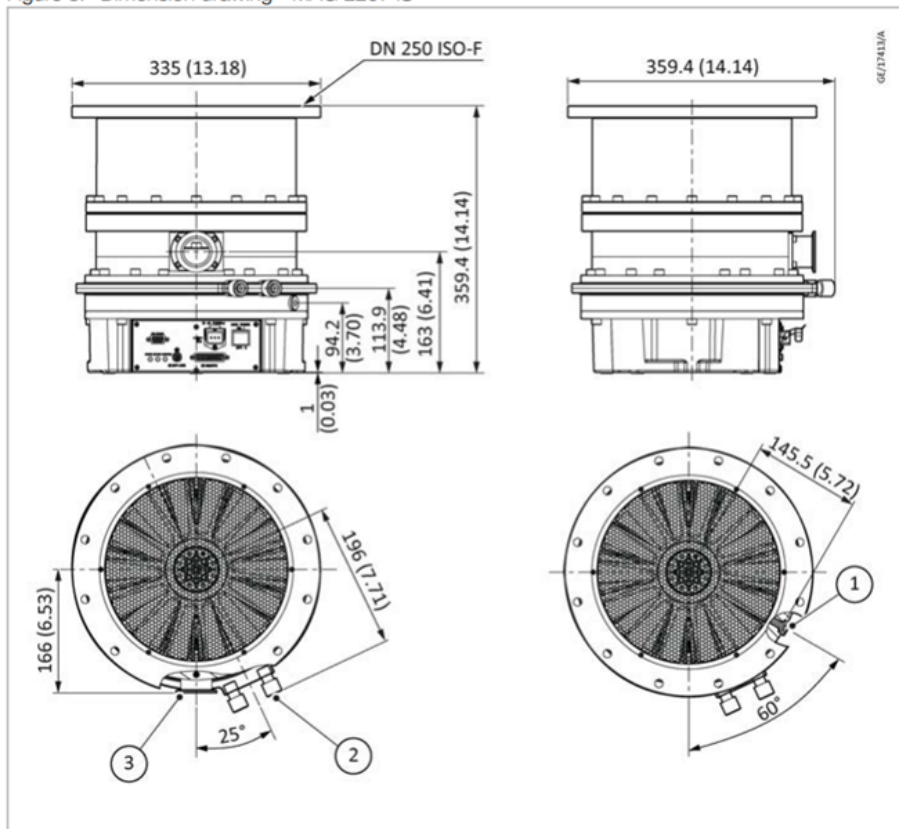

1. Purge gas M10x1.25
2. Forevacuum connection DN 40 KF
3. Water cooling port Rc 1/4

1. Purge gas M10x1.25
2. Forevacuum connection DN 40 KF

Typical Applications

- Coating Applications
- Space Simulation Chambers
- Nuclear Fusion
- Beamlines
- Vacuum Ovens
- EUV Lithography

Figure 9. Dimension drawing - MAG 2807 iS

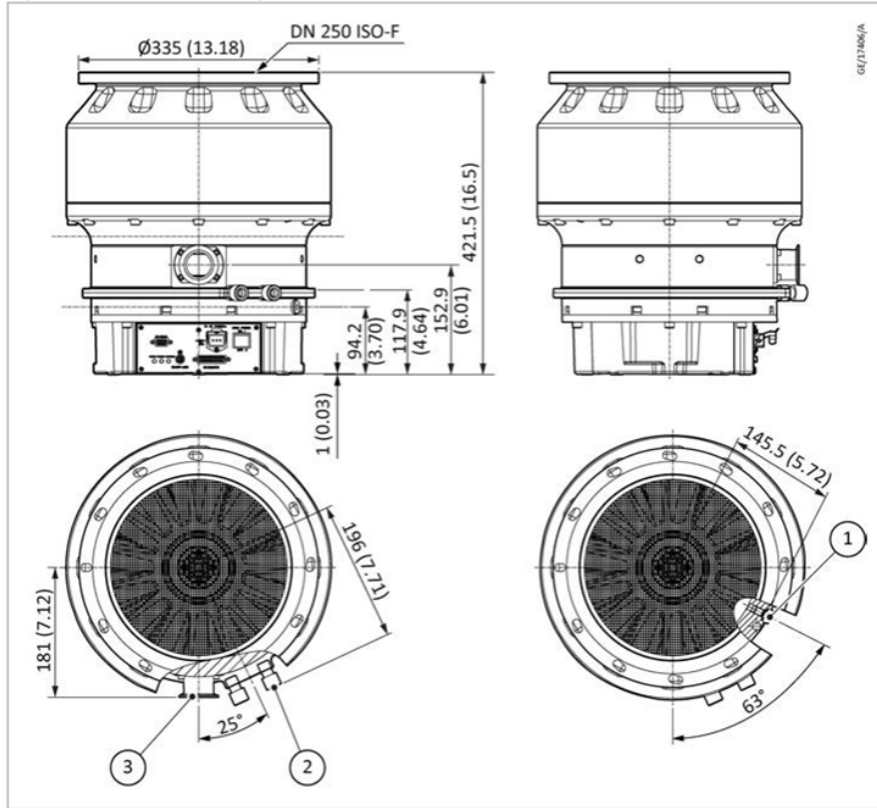

1. Purge gas M10x1.25
2. Water cooling port Rc 1/4
3. Forevacuum connection DN 40 KF

Technical Features

- Installation in any orientation
- DN 250 or 320 in ISO-F (CF or VG high vacuum connection up on request)
- DN 40 KF forevacuum connection
- Purge gas/venting port (Blanked off); PURGE ADAPTER SET 412207V01 must be ordered separately to use vent valve (DN 10/16 KF with clamped connection)
- Water cooling
- Standard ProfiBus
- Further interfaces can be fitted: RS485/232, 25 pin 24 V PLC.
- STP- Link for control, monitoring, parameter setting, data logging, etc.

Figure 10. Dimension drawing - MAG 3207 iS

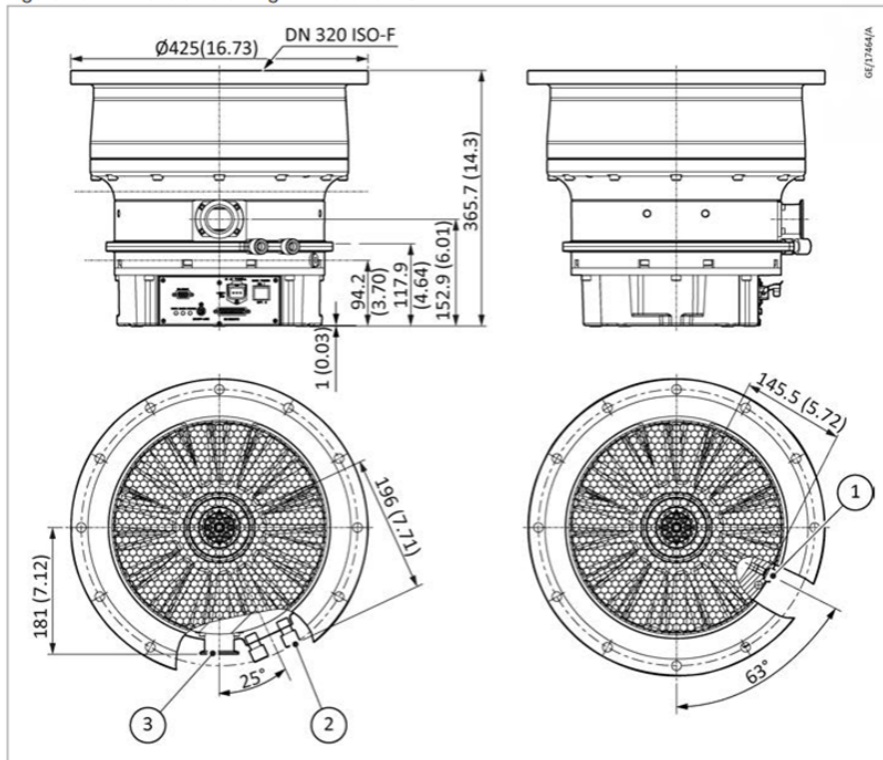

1. Purge gas M10x1.25
2. Water cooling port Rc 1/4
3. Forevacuum connection DN 40 KF

Advantages to the User

- Highest pumping speed and gas throughput from the smallest size and lightest weight in the Market.
- Maximal flexibility in installation. Compact design. Can be mounted in any direction. All connections (Forevacuum flange -, Purge gas port -, interface - and Mains connection) on the same side to install.
- Rugged and reliable operation in industrial applications
- Sets new benchmarks for minimal maintenance systems.
- Suited for vibration sensitive applications in the areas of analytical, thin-film, electron microscopy, research and development among others.

Technical Data

		MAG 2207 iS	MAG 2807 iS	MAG 3207 iS
High vacuum flange	DN	250 ISO-F	250 ISO-F	320 ISO-F
Pumping speed (PNEUROP)				
N ₂	l x s ⁻¹	2200	2350	3200
Ar	l x s ⁻¹	2000	2150	3000
H ₂	l x s ⁻¹	1030	1850	1950
He	l x s ⁻¹	1800	2500	2750
Maximum compression				
Ar			≥ 10 ⁷	
H ₂		2.5 x 10 ²	1 x 10 ³	1 x 10 ³
Maximum gas throughput *#				
Ar	mbar l s ⁻¹	16	26	26
H ₂	mbar l s ⁻¹	54	33	33
Maximum forevacuum pressure	mbar	1.1	1.4	1.4
Nominal/Maximum speed	rpm	36480	31800	31800
Minimum speed	rpm		18240	
Backup rotational speed †	rpm		approximately 6000	
Ultimate pressure	mbar		1 x 10 ⁻⁸	
Maximum bake-out temperature	°C		120	
Run-up time	kg	≤ 8	≤ 10	
Forevacuum flange	DN		40 KF	
Cooling connection			Rc 1/4 (Female)	
Weight, approximate	kg	45	59	57
Noise level	dB		< 55	

* The maximum gas throughput for continuous operation in connection with N₂ or Ar is attainable with a cooling water temperature below 25 °C and a forevacuum pump system having a pumping speed of over 600 m³/h. These values may differ for other operating conditions.

#Maximum gas throughput and maximum forevacuum pressure cannot be attained simultaneously.

† A backup rotational speed is the lowest rotational speed to which the magnetic bearing can be backed up at a power failure.

Technical Data

Integrated frequency converter

Input voltage	V a.c.	200 to 240 ± 10%
Input power	V A	750 maximum
Input frequency	Hz	50/60 ± 2
Leakage current	mA	2.0 maximum
Main fuse specification	A	6.3
Current Ampere Interrupting Capacity (AIC)	A	100 (250 V a.c. 50/60 Hz)
Pollution degree		2
Installation category		II
Motor driving system		3-phase d.c. brushless motor driver

Technical Data

Operating environment

Ambient temperature	0 to 40 °C (32 to 104 °F)
Ambient relative humidity	30 to 95% (no dew condensing)
Environment	An area free of externally applied mechanical shock.
	A place free of a heat source (Keep clear of the heat source or attach a thermal shield plate).
	A place free of a strong magnetic field (Range: up to 15mT (150 G) in the axial direction, and up to 3 mT (30 G) in the radial direction with respect to the rotational axis of the pump).
	A place free of a strong electric field.
	A place free of exposure to radiation.
	No discharge of high voltage (more than 500 V) (If more than 500 V is discharged, contact us).
	Others: An area free of exposure to direct sunlight, high humidity, dust, water drop, salty air, explosive or flammable gas, corrosive gas, excessive vibration and sources of electric noise.
Pump installation equipment conditions	A place at an altitude of 2000 m or less.
	Install the pump securely so that foreign materials cannot fall into the pump. Install the pump so that the inlet flange of the pump is not exposed to a heat source.

Ordering Information

412200V7704	TURBOVAC MAG 2207 iS - DN 250 ISO-F; ProfiBus	
412200V7724	TURBOVAC MAG 2207 iS - DN 250 ISO-F; RS485	
412800V7704	TURBOVAC MAG 2807 iS - DN 250 ISO-F; ProfiBus	
412800V7724	TURBOVAC MAG 2807 iS - DN 250 ISO-F; RS485	
413200V7704	TURBOVAC MAG 3207 iS - DN 320 ISO-F; ProfiBus	
413200V7724	TURBOVAC MAG 3207 iS - DN 320 ISO-F; RS485	

Ordering Information

Accessories	Part No.
Purge adapter set	412207V01
Purge and Vent Valves 36sccm NC (1,0-6 bar; ISO-KF 16 - G1/4" or 6mm flex)	12133
Purge and Vent Valves 36sccm NC (1.0-1.5 bar; ISO-KF 10 - G1/4" or 6mm flex)	800152V0010
Included in the Delivery of the Pump	
Flanges for forevacuum is blank-flanged (covered with a cap)	
Purge gas port is blanked off	
A mains mating connector for the mains connection is supplied. A cable and a mains plug are not part of the standard equipment.	
Inlet screen equipped	
STP-Link connecting cable, 3m	412207V03

Leybold standard parts

Centering rings	
Centering Ring - Al/FPM, O-Ring DN 250 ISO-K	26845
Centering Ring - Al/CR, O-Ring DN 250 ISO-K	26817
Centering Ring - Al/FPM, O-Ring DN 320 ISO-K	26846
Centering Ring - Al/CR, O-Ring DN 320 ISO-K	26818
Centering Ring - Stainless steel/FPM. O-Ring DN 250 ISO-K	88708
Set of bolts, nuts and washers for ISO-F flange	
Set M10x35, 12.9	400153V0023
Set M10x50, 12.9	400153V0022
Set M10x50 (Stud bolts), 12.9	400153V0019
Set M12x45, 12.9	400153V0020
Set M12x60, 12.9	400153V0021

TURBOVAC MAG 2207 iS

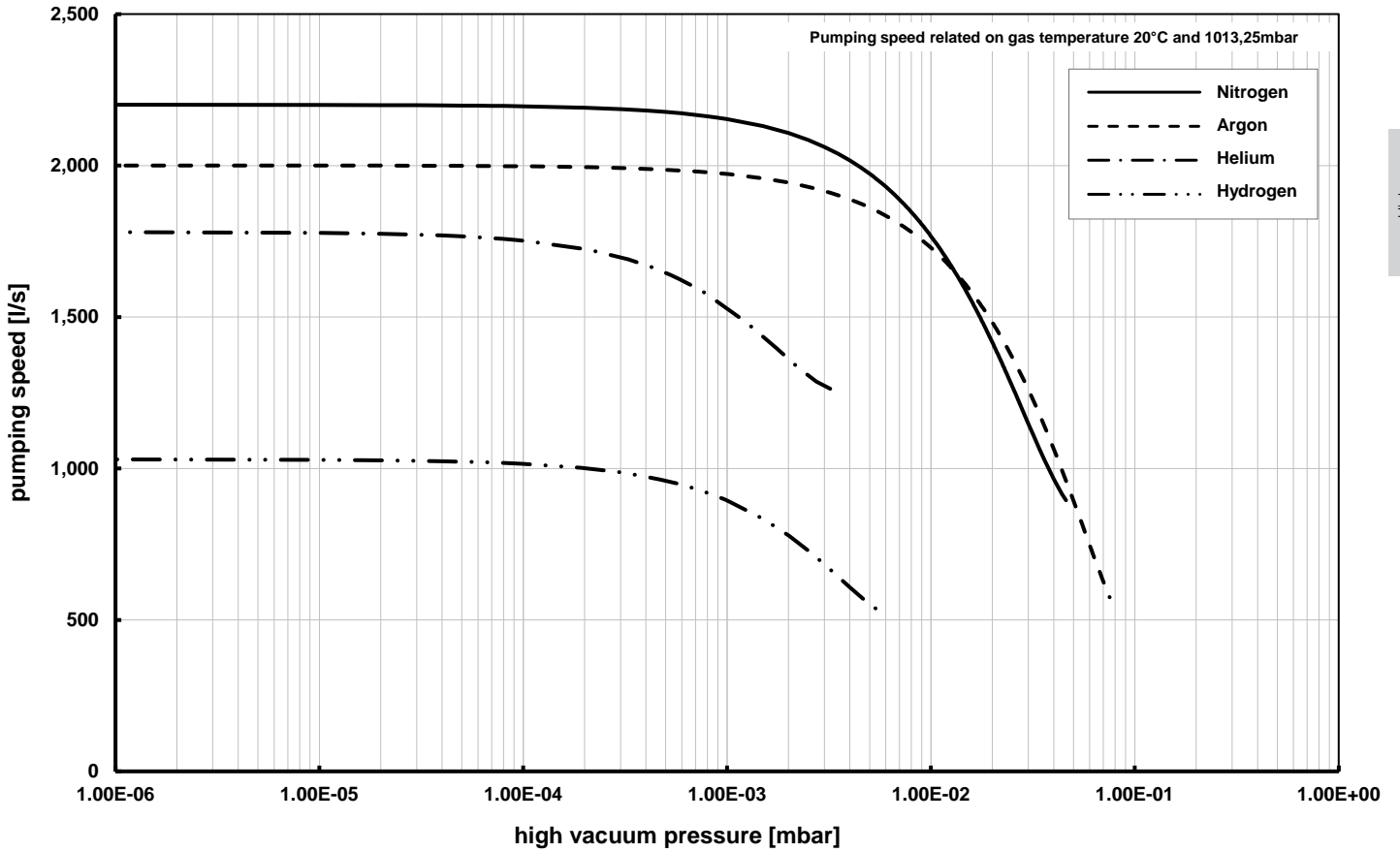

High Vacuum Pumps

TURBOVAC MAG 2807 iS

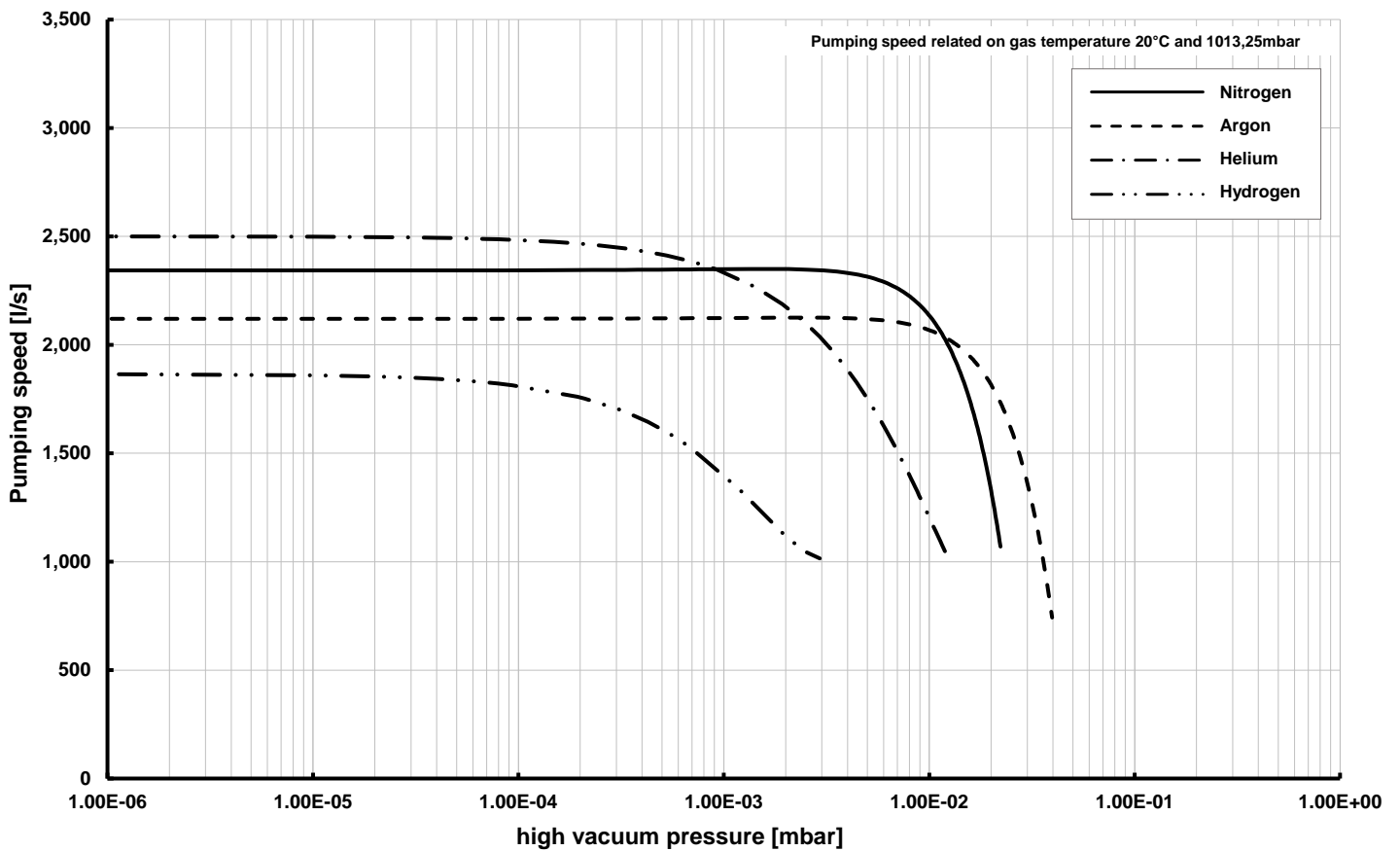

TURBOVAC MAG 3207 iS

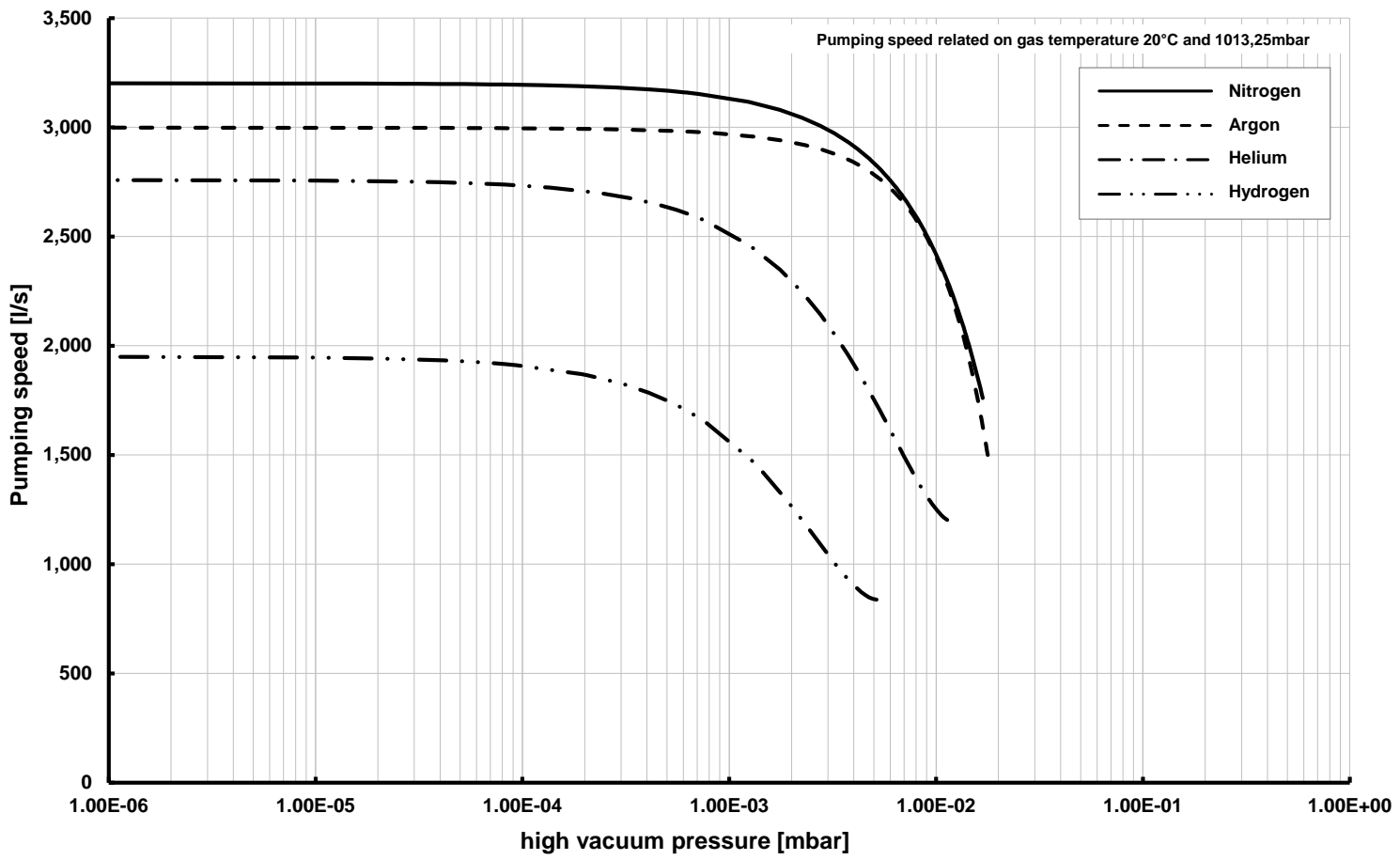

MAG INTEGRA – Magnetic Rotor Suspension with integrated Frequency Converter, with and without Compound Stage TURBOVAC MAG W 1300 iP(L) to 2201 iP(L)



Typical Applications

- PVD coatings systems
- Coating of architectural glass
- Optical coatings
- LC displays
- Flat panels
- Research
- Analytical systems

Technical Features

- Installation in any orientation
- DN 200 and/or 250 in ISO-F and/or CF high vacuum connection
- DN 40 KF forevacuum connection
- Purge gas/venting connection DN 16 KF with clamped connection (purge/vent)
- Water cooling
- Protection class IP 54
- RS 232 C in Service Slot
- 1 slots for industrial communications modules
 - Standard ProfiBus
 - further interfaces can be fitted: RS 485 C, 9 pin 24 V PLC, DeviceNet, EtherNet IP, EtherCat, ProfiNet

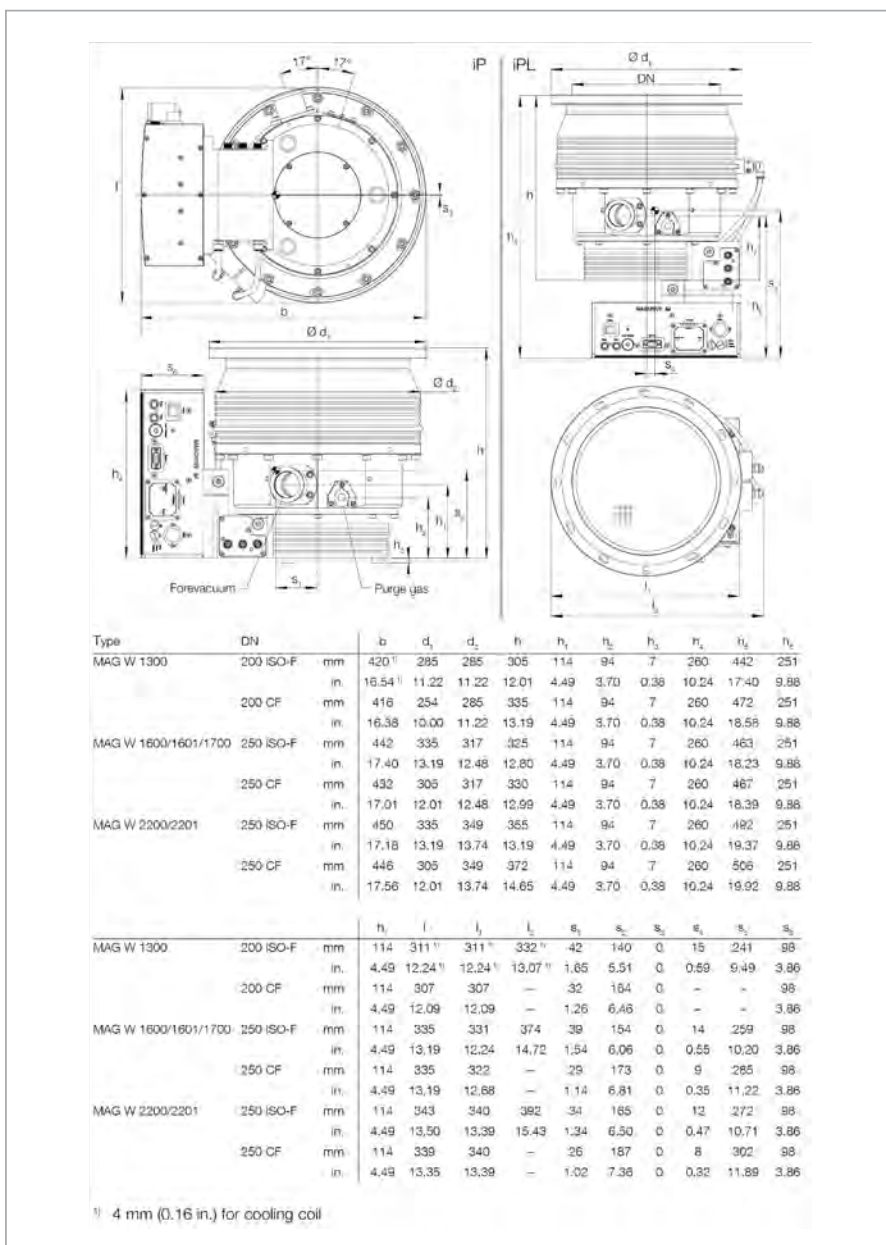

Dimensional drawing for the MAG INTEGRA, dimensions in mm

Advantages to the User

- Highest pumping speed and gas throughput from a very small size
- Rugged and reliable operation in industrial applications
- Sets new benchmarks for maintenance-free systems
- Suited for vibration sensitive applications in the areas of analytical, thin-film, electron microscopy, research and development among others.
- Flexibility through the modular concept; the converter is either attached to the side or under the pump

Technical Data

TURBOVAC MAG W

		1300 iP(L)	1600 iP(L) Booster	1601 iP(L) Booster	1700 iP(L)	2200 iP(L)	2201 iP(L)
Inlet flange	DN	200 ISO-F 200 CF	250 ISO-F	250 ISO-F	250 ISO-F 250 CF	250 ISO-F 250 CF	250 ISO-F
Pumping speed							
N ₂	l/s	1100	1600	1600	1610	2100	2100
Ar	l/s	1050	1470	1470	1480	1900	1900
He	l/s	1220	1770	1770	1710	2050	2050
H ₂	l/s	1130	1570	1570	1500	1750	1750
Operating speed		37 800	33 000	33 000	33 000	30 600	30 000
standby speed adjustable from to nominal speed	min ⁻¹ min ⁻¹	13 800 (230 Hz)	13 800 (230 Hz)	13 800 (230 Hz)	13 800 (230 Hz)	13 800 (230 Hz)	13 800 (230 Hz)
Max. compression ratio							
N ₂		> 10 ⁸	> 10 ⁷	> 10 ⁷	> 10 ⁸	> 10 ⁸	> 10 ⁸
Ar		> 10 ⁸	> 10 ⁷	> 10 ⁷	> 10 ⁸	> 10 ⁸	> 10 ⁸
He at 1 sccm		2 x 10 ⁵	6 x 10 ⁴	3 x 10 ³	2 x 10 ⁵	5 x 10 ⁴	5 x 10 ³
H ₂ at 1 sccm		8 x 10 ³	1 x 10 ³	5 x 10 ²	4 x 10 ³	5 x 10 ³	5 x 10 ²
Max. gas throughput							
N ₂ briefly, e.g. during pump down	mbar x l/s	30	60	60	30	30	50
N ₂ in continuous operation	mbar x l/s	20	30	40	20	17	36
Ar briefly, e.g. during pumpdown	mbar x l/s	20	30	30	20	20	30
Ar in continuous operation	mbar x l/s	15	20	25	15	12	24
Ultimate pressure		< 10 ⁻⁸ (< 7.5 x 10 ⁻⁹)	< 10 ⁻⁸ (< 7.5 x 10 ⁻⁹)	< 10 ⁻⁸ (< 7.5 x 10 ⁻⁹)	< 10 ⁻⁸ < 10 ⁻¹⁰ (< 7.5 x 10 ⁻¹¹)	< 10 ⁻⁸ < 10 ⁻¹⁰ (< 7.5 x 10 ⁻¹¹)	< 10 ⁻⁸ (< 7.5 x 10 ⁻⁹)
ISO-F flange	mbar (Torr)	< 10 ⁻¹⁰ (< 7.5 x 10 ⁻¹¹)	-	-	< 10 ⁻¹⁰ (< 7.5 x 10 ⁻¹¹)	< 10 ⁻¹⁰ (< 7.5 x 10 ⁻¹¹)	-
CF flange	mbar (Torr)						
Max. degassing temperature	°C (°F)	80 (176)					
Max. foreline pressure							
N ₂	mbar (Torr)	4.0 (3.00)	1.0 (0.75)	1.0 (0.75)	4.0 (3.00)	2.5 (1.9)	1.2 (0.91)
Ar	mbar (Torr)	0.6 (0.45)	1.0 (0.75)	1.0 (0.75)	0.6 (0.45)	2.5 (1.9)	1.2 (0.91)
Recommended backing pump		TRIVAC B or dry compressing pumps					
Run-up time	min	< 5	< 7	< 7	< 7	< 10	< 10
Foreline flange	DN	40 KF					
Purge / vent port (clamped)	DN	16 KF					
Water cooling connection	G	1/8"					
Weight, approx.	kg (lbs)	40 (88)	45 (99)	45 (99)	45 (99)	50 (110)	50 (110)
Noise level acc. ISO 3744	dB(A)	< 41					
Vibration level at high vacuum flange at max. speed	µm	0.01					

Technical Data

Integrated Frequency Converter MAG.DRIVE iM

Power supply	V	200 – 240 ±10%					
Mains frequency	Hz	50 / 60					
Power consumption maximum	W	750					
at ultimate pressure	W	150					
Contact rating for the relays, max.		32 V; 0.5 A					
Permissible ambient tempera- ture							
during operation	°C (°F)	+10 to +45 (+50 to +113)					
during storage	°C (°F)	-10 to +60 (+14 to +140)					
Relative humidity of the air, non-condensing	%	5 to 85					
Protection class	IP	54					
Overvoltage category		11					
Pollution category		2					

Ordering Information

TURBOVAC MAG W1300/1600/1601/ 1700/2200/2201 iP(L)

TURBOVAC MAG W 1300 with Integrated Frequency Converter and Purge Gas Connection	P FC PS	Part No.	
MAG W 1300 iP, DN 200 ISO-F, Profibus MAG W 1300 iP, DN 200 ISO-F, 24 V SPS interface MAG W 1300 iP, DN 200 CF, Profibus MAG W 1300 iP, DN 200 CF, 24 V SPS interface MAG W 1300 iPL, DN 200 ISO-F, Profibus MAG W 1300 iPL, DN 200 ISO-F, 24 V SPS interface MAG W 1300 iPL, DN 200 CF, Profibus MAG W 1300 iPL, DN 200 CF 24 V SPS interface		411300V0504 411300V0514 411300V0506 411300V0516 411300V0704 411300V0714 411300V0706 411300V0716	
TURBOVAC MAG W 1600 Booster with Integrated Frequency Converter and Purge Gas Connection	P FC PS	Part No.	
MAG W 1600 iP Booster, DN 250 ISO-F, Profibus MAG W 1600 iP Booster, DN 250 ISO-F, 24 V SPS interface MAG W 1600 iPL Booster, DN 250 ISO-F, Profibus MAG W 1600 iPL Booster, DN 250 ISO-F, 24 V SPS interface		411600V0504 411600V0514 411600V0704 411600V0714	
TURBOVAC MAG W 1601 Booster with Integrated Frequency Converter and Purge Gas Connection	P FC PS	Part No.	
MAG W 1601 iP Booster, DN 250 ISO-F, Profibus MAG W 1601 iP Booster, DN 250 ISO-F, 24 V SPS interface MAG W 1601 iPL Booster, DN 250 ISO-F, Profibus MAG W 1601 iPL Booster, DN 250 ISO-F, 24 V SPS interface		411600V2504 411600V2514 411600V2704 411600V2714	
TURBOVAC MAG W 1700 with Integrated Frequency Converter and Purge Gas Connection	P FC PS	Part No.	
MAG W 1700 iP, DN 250 ISO-F, Profibus MAG W 1700 iP, DN 250 ISO-F, 24 V SPS interface MAG W 1700 iP, DN 250 CF, Profibus MAG W 1700 iP, DN 250 CF, 24 V SPS interface MAG W 1700 iPL, DN 250 ISO-F, Profibus MAG W 1700 iPL, DN 250 ISO-F, 24 V SPS interface MAG W 1700 iPL, DN 250 CF, Profibus MAG W 1700 iPL, DN 250 CF, 24 V SPS interface		411700V0504 411700V0514 411700V0506 411700V0516 411700V0704 411700V0714 411700V0706 411700V0716	
TURBOVAC MAG W 2200 with Integrated Frequency Converter and Purge Gas Connection	P FC PS	Part No.	
MAG W 2200 iP, DN 250 ISO-F, Profibus MAG W 2200 iP, DN 250 ISO-F, 24 V SPS interface MAG W 2200 iP, DN 250 CF, Profibus MAG W 2200 iP, DN 250 CF, 24 V SPS interface MAG W 2200 iPL, DN 250 ISO-F, Profibus MAG W 2200 iPL, DN 250 ISO-F, 24 V SPS interface MAG W 2200 iPL, DN 250 CF, Profibus MAG W 2200 iPL, DN 250 CF, 24 V SPS interface		412200V0504 412200V0514 412200V0506 412200V0516 412200V0704 412200V0714 412200V0706 412200V0716	
TURBOVAC MAG W 2201 Booster with Integrated Frequency Converter and Purge Gas Connection	P FC PS	Part No.	
MAG 2201 iP, DN 250 ISO-F, Profibus MAG 2201 iP, DN 250 ISO-F, 24 V SPS interface MAG 2201 iPL, DN 250 ISO-F, Profibus MAG 2201 iPL, DN 250 ISO-F, 24 V SPS interface		412200V2504 412200V2514 412200V2704 412200V2714	

Other interfaces upon request

With integrated Frequency Converter and Power Supply



MAG W 1300 iP(L),
 MAG W 1600/1601 iP(L) Booster,
 MAG W 1700 iP(L),
 MAG W 2200/2201 iP(L)

Ordering Information

**TURBOVAC MAG
 W1300/1600/1601/
 1700/2200/2201 iP(L)**

Mandatory Accessories	P	Part No.
Set of bolts, nuts and washers for ISO-F flange (12 each) Bolts M 10 x 50 Bolts M 10 x 35		400153V0012 400153V0010
Centering with O-ring AI/FPM DN 200 DN 250 Stainless steel/FPM DN 200 DN 250		268 44 268 45 887 02 887 08
Set of bolts, nuts and washers for CF flange (8 each) Bolts M 8 x 40 (For DN 200, 3 sets are required; for DN 250, 4 sets)		400153V0016
Copper gasket rings for CF flange DN 200 (Set of 10 pieces) DN 250 (Set of 5 pieces)		839 47 839 48
Set of hex. bolts with nuts, bolts and washers for CF flange DN 200 DN 250 (2 sets required)		839 07 839 07
Accessories, optional	P FC PS	
Mains cable, 2.5 m (8.75 ft) with EURO plug with US plug		411310V03 411320V03
Seal Kit DN 250 Metal		200 07 901
Seal kit, metal, for other flanges		Upon request
Purge gas and venting valve 24 V DC 0.6 mbar-l/s at 1.5 to 6 bar 0.6 mbar-l/s at 1 to 1.5 bar Cable set (2 pieces) for connection to the pump		121 33 800152V0010 411300V01
Cooling water valve kit		411300V02
Spare Parts Inlet screen DN 200 ISO-F and DN 200 CF DN 250 ISO-F and DN 250 CF		E 200 04 558 E 200 04 557
Included in the Delivery of the Pump	P	
Flanges for forevacuum, venting and purge gas are blank-flanged		
Converter-side mains plug (IP 54)		
Inlet screen		

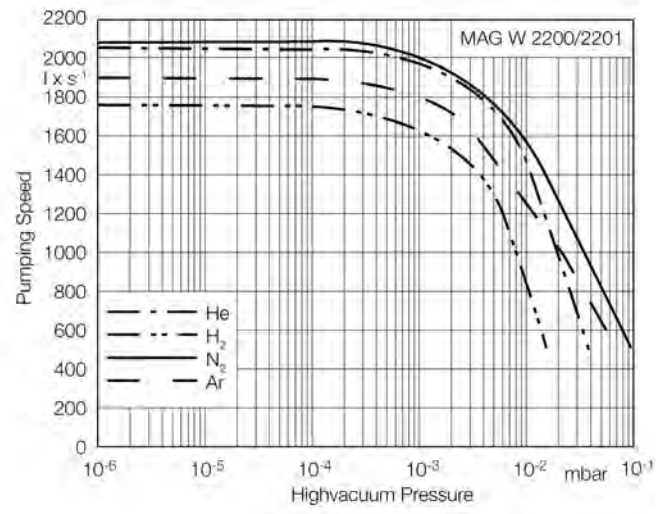
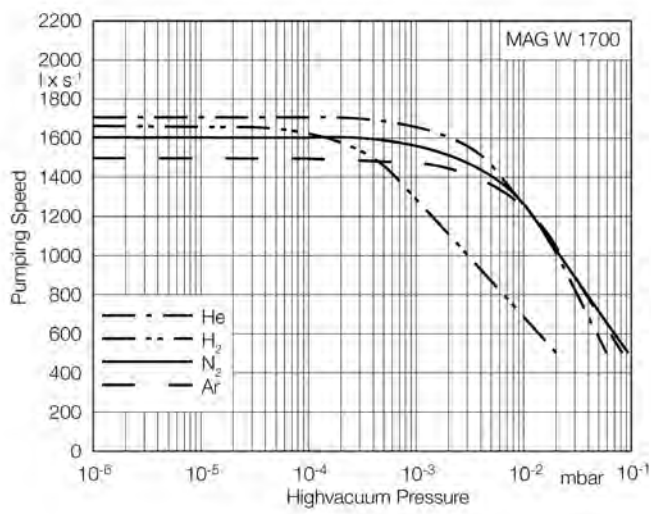
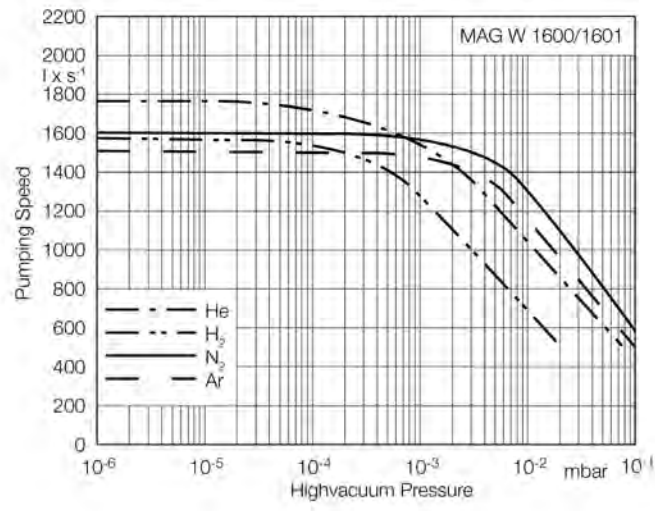
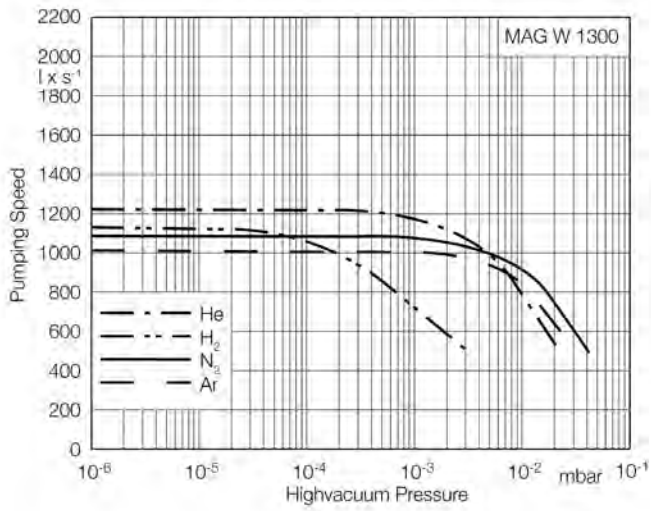

Pumping speed curves of the MAG W 1300, W 1600, W 1700 and W 2200

Vibration Absorber

Vibration absorbers are used to inhibit the propagation of vibrations from the turbomolecular pump to highly sensitive instruments like electron beam microscopes, micro-balances or analytical instruments



Ordering Information

Vibration Absorber

		Part No.
Vibration absorber		
DN 063 ISO-K	066 mm (2.60 in.) long	800131V0063
DN 063 CF	081 mm (3.19 in.) long	500 070
DN 100 ISO-K	084 mm (3.31 in.) long	800131V0100
DN 100 CF	100 mm (4.09 in.) long	500 071
DN 160 ISO-K	084 mm (3.31 in.) long	500 073
DN 160 CF	104 mm (4.09 in.) long	500 072

Flange Heater for CF High Vacuum Flanges

Most TURBOVAC pumps can be baked out in order to improve the ultimate pressure attained in the UHV range. Degassing of the turbomolecular pump will only be useful when simultaneously baking out the vacuum chamber.

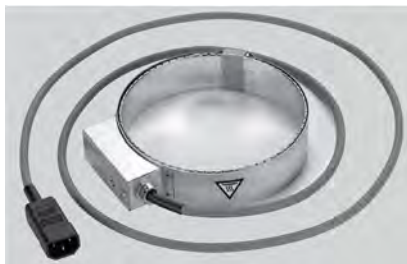

Technical Data

Flange Heater

Rated power consumption of the flange heater		
DN 063 CF, DN 100 CF	W	100
DN 160 CF	W	150
Voltage	V AC	230 or 115
Cable length	mm	1600
Max. temperature	°C	100

Ordering Information

Flange Heater

	Part No.	Part No.
Flange heater		
DN 063 CF	230 V 800137V0003	115 V 800137V0004
DN 100 CF	800137V0005	800137V0006
DN 160 CF	800137V0007	800137V0008

Fine Filter

A fine filter integrated in the centering ring protects the pump against particles and dust on the high vacuum side.



Ordering Information

Flange Heater

	Part No.
Connection flange of the fine filter	
DN 040 ISO-KF	883 98
DN 063 ISO-K	887 20
DN 100 ISO-K	887 21

Solenoid Venting Valve



Technical Data

Venting Valve

Drive voltage	V DC	24
Power consumption	W	4
Connecting flange	DN	16 ISO-KF
Weight, approx.	kg (lbs)	0.3 (0.66)

Ordering Information

Venting Valve

	Part No.
Solenoid venting valve, normally closed	800120V0011

Power Failure Venting Valve



Technical Data

Power Failure Venting Valve

Drive voltage	V DC	24
Power consumption	W	4
Connecting flange	DN	16 ISO-KF
Weight, approx.	kg (lbs)	0.3 (0.66)

Ordering Information

Power Failure Venting Valve

	Part No.
Power failure venting valve, normally open	800120V0021

Power Failure Venting Valve, Electromagnetically Actuated

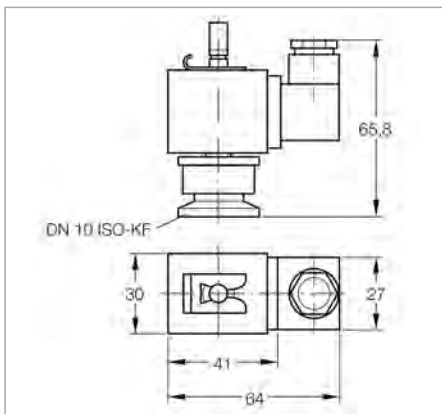

Technical Data

Power Failure Venting Valve

Technical data	See Catalog "Valves", para. "Special Valves"
----------------	--

Ordering Information

Power Failure Venting Valve

	Part No.
Power failure venting valve DN 10 ISO-KF, electromagnetically actuated	
024 V DC	174 46
230 V AC / 50/60 Hz	174 26

Dimensional drawing for the electromagnetically actuated power failure venting valve

Purge Gas and Venting Valve



Technical Data

Connecting flange	DN
Weight, approx.	kg (lbs)

Purge Gas and Venting Valve

10 ISO-KF
0.7 (1.55)

Ordering Information

Purge Gas and Venting Valve

	Part No.
Purge gas and venting valve, 230 V	
0.2 mbar x l/s (12 sccm)	855 19
0.4 mbar x l/s (24 sccm)	855 29

Purge Gas and Venting Valve

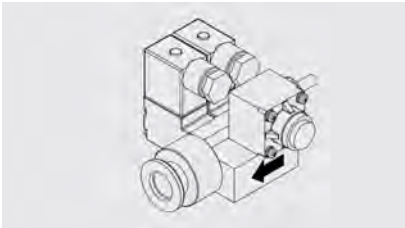

Technical Data

Connecting flange	DN
Inlet	
Outlet	
SPurge gas pressure, abs.	bar
Weight, approx.	kg (lbs)

Power Failure Venting Valve

1/4" tube
pump specific or DN 16 ISO-KF

1.5 to 6,0
0.3 (0.66)

Ordering Information

Power Failure Venting Valve

	Part No.
Purge gas and venting valve	
24 V DC; 0,6 mbar x l/s	121 33

Further 0.6 mbar x l/s valves upon request

Gas Filter to G 1/4" for Purge Gas and Venting Valve

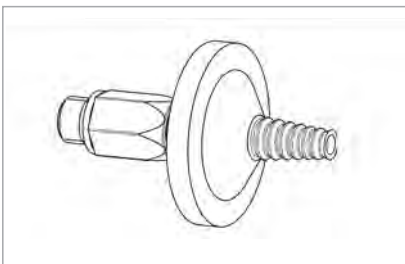

Technical Data

Gas filter
including fitting G 1/4" and 2 gaskets

Gas filter

Ordering Information

Gas filter

	Part No.
Gas filter to G 1/4"	
for seal gas and venting valve	800110V0012
Replacement filter for gas filter to G 1/4"	
for seal gas and venting valve	E 200 18 515

Accessories for Serial Interfaces RS 232 C and RS 485 C

Through these accessories many control, monitoring and information capabilities can be implemented in

connection with the electronic frequency converters and turbomolecular pumps.

All turbomolecular pumps or electronic frequency converters are supported.

PC Software LEYASSIST



Software platform* developed to intuitively control, configure, monitor Leybold vacuum products and intelligent systems through USB or serial RS232 / RS485 to USB interfaces.

Functionality:

- Auto connect to Leybold Vacuum products
- Configure and control products
- Checking alarm warning status and doing trouble shooting
- Easy configuration of intelligent pump systems around local Hub products such as TURBOVAC i / iX
- Enabling Plug&Play

* available as free download from our website

Interface Adaptor for Frequency Converter with RS 232 C/RS 485 C Interface

Ordering Information

Interface Adaptor RS 232 C/RS 485 C

	Part No.
Adaptor RS 232 C/RS 485 C mains connection 230 V, 50 Hz, EURO plug	800110V0101
Adaptor USB/RS 232 C for connection of RS 232 C to USB (PC), including CD with drivers and manual	800110V0103

Miscellaneous

Services for Mechanically Suspended Turbomolecular Pumps

Complete Refurbishing at the Service Centre

Complete refurbishing at the service centre includes the following:

Complete disassembly, cleaning, replacement of all wearing parts, mounting, electrical safety test, final test including vibration measurement

Complete Refurbishing with Decontamination at the Service Centre

Complete refurbishing with decontamination at the service centre includes the following:

Complete disassembly, cleaning and decontamination, replacement of all wearing parts, mounting, electrical safety test, final test including vibration measurement

Ordering Information

Complete Refurbishing at the Service Centre

Complete Refurbishing with Decontamination at the Service Centre

	Part No.	Part No.
For Pump		
TURBOVAC 35 / 50D	AS 2165	AS 2165 D
TURBOVAC 50	AS 2133	AS 2133 D
TURBOVAC SL 80	LAS 2368	LAS 2368 D
TURBOVAC TW 70 H	AS 2368	AS 2368 D
TURBOVAC 151	AS 2134	AS 2134 D
TURBOVAC TW 250 S	AS 2168	AS 2168 D
TURBOVAC SL 300	LAS 2369	LAS 2369 D
TURBOVAC TW 300	AS 2369	AS 2369 D
TURBOVAC 361	AS 2135	AS 2135 D
TURBOVAC 600 / 1000	AS 2136	AS 2136 D
TURBOVAC TW 701 / 690	AS 2330	AS 2330 D
TURBOVAC 1100	AS 2137	AS 2137 D

Services for Magnetically Levitated Turbomolecular Pumps

Complete Refurbishing at the Service Centre

Complete refurbishing at the service centre includes the following:

Complete disassembly, cleaning, replacement of all wearing parts, mounting, electrical safety test, final test including vibration measurement

Complete Refurbishing with Decontamination at the Service Centre

Complete refurbishing with decontamination at the service centre includes the following:

Complete disassembly, cleaning and decontamination, replacement of all wearing parts, mounting, electrical safety test, final test including vibration measurement

Ordering Information

Complete Refurbishing at the Service Centre

Complete Refurbishing with Decontamination at the Service Centre

	Part No.	Part No.
For Pump		
MAG W 300 / 400	AS 2300	AS 2300 D
MAG W 600 / 700	AS 2600	AS 2600 D
MAG W 1300 iP (L) – 2201 iP (L)	AS 2700	AS 2700 D
MAG (W) 1600 / 2000	AS 2164 ¹⁾	AS 2164 D ¹⁾
MAG (W) 830 / 1300 / 1500	AS 2370 ¹⁾	AS 2370 D ¹⁾
MAG 900 / 1000 / 1200	AS 2160 ¹⁾	AS 2160 D ¹⁾
MAG 2200	AS 2200 ¹⁾	AS 2200 D ¹⁾
MAG 2800 / 3200	AS 2800 ¹⁾	AS 2800 D ¹⁾

Notes

The listed services include the costs for material and working hours for standard pumps. Services for pump variants upon request.

If additional spare parts are needed for repairs, then these are invoiced separately according to a cost estimate.

¹⁾ Including rotor replacement

General

Applications and Accessories for Oil Diffusion Pumps

Pumps														
	DIP 3000	DIP 8000	DIP 12000	DIP 20000	DIP 30000	DIP 50000	DIJ 10 / 320	DIJ 16 / 500	DIJ 20 / 630	DIJ 32 / 800	OB 6000	OB 12000	OB 18000	
Applications														
Vacuum coating (e.g. Sputtering)	■	■	■	■	■	■	■	■	■	■	■	■	■	■
Research and development	■	■	■	■	■	■	■	■	■	■	■	■	■	■
Metallurgy/furnaces	■	■	■	■	■	■	■	■	■	■	■	■	■	■
Mechanical engineering	■	■	■	■	■	■	■	■	■	■	■	■	■	■
Sputtering process						■	■	■	■	■	■	■	■	■
Secondary metallurgy (e.g. VIM, VID)											■	■	■	■
High vacuum furnaces											■	■	■	■
Cristal growing plants						■	■	■	■	■				
Electron beam welding						■	■	■	■	■				
Nitride hardening						■	■	■	■	■				
Drying plants						■	■	■	■	■				

Accessories	Page														
Astrotorus baffle	90	■	■	■	■	■	■	■	■	■	■	■			
Over-temperature protection switch	92	■	■	■	■	■	■	■	■	■	■				
Contact thermometer	92	■	■	■	■	■									
Resistance thermometer Pt100	92	■	■	■	■	■									
Water flow monitor	93	■	■	■	■	■	■	■	■	■	■				
Energy efficiency controller	94				■	■	■					■	■	■	
Valves	95	Right-angle valves, electropneumatically operated, DN 250 ISO-K to DN 1000 ISO-K													

Oil for Diffusion Pumps for different fields of application

Applications					
	Vacuum coating	Research and development	Metallurgy/furnaces	Mechanical engineering	Sputter processes
LEYBONOL Oils					
LVO 500	■	■	■	■	■
LVO 510	●	●	●	●	●
LVO 520	●	●			
LVO 530	●	●			
LVO 540 ¹⁾	■	■	■	■	■

■ = Standard
● = Standard

¹⁾ Only for OB pumps

The table only lists general applications. Your specific requirements might be subject to deeper analysis. For further questions, please contact our technical Sales support.

Oil for Diffusion Pumps for different fields of application

Pumps	DIP 3000	DIP 8000	DIP 12000	DIP 20000	DIP 30000	DIP 50000	DIJ 10* / 320	DIJ 16* / 500	DIJ 20 / 630	DIJ 35* / 1000	OB 6000	OB 12000	OB 18000
LEYBONOL Oils													
LVO 500	■	■	■	■	■	■	■	■	■	■			
LVO 510	●	●	●	●	●	●	●	●	●	●			
LVO 520	●	●	●	●	●	●	●	●	●	●			
LVO 530	●	●	●	●	●	●	●	●	●	●			
LVO 540 ¹⁾											■	■	■

■ = Standard

● = Standard

Note

All oils may be used.

The pumps are supplied as standard without oil

The table only lists general applications. Your specific requirements might be subject to deeper analysis. For further questions, please contact our technical Sales support.

For information on oil specifications please refer to Catalog Part "Oils / Greases / Lubricants LEYBONOL®".

Operating Principle of Fluid Entrainment Vacuum Pumps

The main components of diffusion pumps, the operation of which relies on vapor-phase pump fluids are:

- Cooled pump body with intake and exhaust ports
- System of nozzles
- Pump boiler

In the case of diffusion pumps a pump fluid contained in a boiler is heated to such an extent that it is vaporized. The vapor is then forced through nozzles within the pump. The nozzles are generally designed in such a way, that they accelerate the vapor to a speed exceeding the speed of sound (Laval nozzles), thus creating a high speed vapor jet. The vapor is then deflected by the nozzles at a specific angle onto the pump body. The pump body is cooled, so that the vaporized pump

fluid condenses and is returned back to the boiler as a liquid. The pumping action of diffusion pumps and fluid entrainment pumps in general is based on the transporting capacity of the vapor jet.

The gas which is to be pumped is compressed sufficiently at the forevacuum port so that it can be pumped out by a backing pump.

Oil Diffusion Pumps

Compared to other fluid entrainment pumps the density of the vapor in the boiler and in the vapor jet is fairly low so that the gas molecules may almost completely diffuse into the vapor jet. Thus most of the molecules which enter the vapor jet are also pumped out.

For this reason, the pumping speed of diffusion pumps is extremely high with respect to the intake area and constant – starting at an inlet pressure of approx. 10^{-3} mbar (0.75×10^{-3} Torr) down to very low pressures – as within the pressure range the vapor jet is not influenced in any way by the pressure within the vacuum vessel.

Operating Oil Diffusion Pumps

Forevacuum

In all cases diffusion pumps require a sufficiently sized backing pump (see Technical Data). The size and type of

forevacuum pump depends on the operating conditions and the quantities of gas which are to be pumped.

1. Continuous operation at operating pressures above 10^{-4} mbar (0.75×10^{-4} Torr) – large quantities of gas.
2. Continuous operation at operating pressures below 10^{-4} mbar (0.75×10^{-4} Torr) – smaller quantities of gas.

In applications which rely on diffusion pumps, the vacuum chamber must be connected via a valve **(3)** and a roughing line directly to the backing pump. This is done so that the vacuum chamber may be pre-evacuated by the backing pump down to a pressure where the diffusion pump can take over. Until the high vacuum valve **(4)** opens, both diffusion pump and pump fluid are preserved. Before venting the vacuum chamber the forevacuum valve **(2)** and the high vacuum valve **(4)** must be closed, whereby the diffusion pump remains in the ready status.

Pumping Speed

The pumping speed of any pump is equivalent to the volume throughput through the intake opening of a pump. In the case of diffusion pumps the pumping speed for lighter gases is higher compared to heavier gases.

Backstreaming of the Pump Fluid

Undesirable backstreaming of molecules from the pump fluid is caused by the effect that some molecules are able to leave the vapor jet and thus do not arrive at the cooled pump body. Because of collisions between each other and due to reflection at the pump body, these molecules are then able to move in the direction of the vacuum chamber.

For DIP pumps the backstreaming effect amounts only to a few μg per cm^2 of intake area per minute. Backstreaming may be almost completely suppressed by including a cold cap baffle or an additional Astrotorus baffle.

Backstreaming of Oil in the Case of Diffusion Pumps

- Pump without baffle
approx. 1×10^{-2} mg x cm^{-2} x min^{-1}
- Pump with cold cap baffle
approx. 1×10^{-3} mg x cm^{-2} x min^{-1}
- Pump with Astrotorus baffle
($T = 10^\circ\text{C}$ (50°F))
approx. 1×10^{-5} mg x cm^{-2} x min^{-1}

The values stated have been measured at an intake pressure of $< 1 \times 10^{-4}$ mbar and apply to LEYBONOL LVO 500.

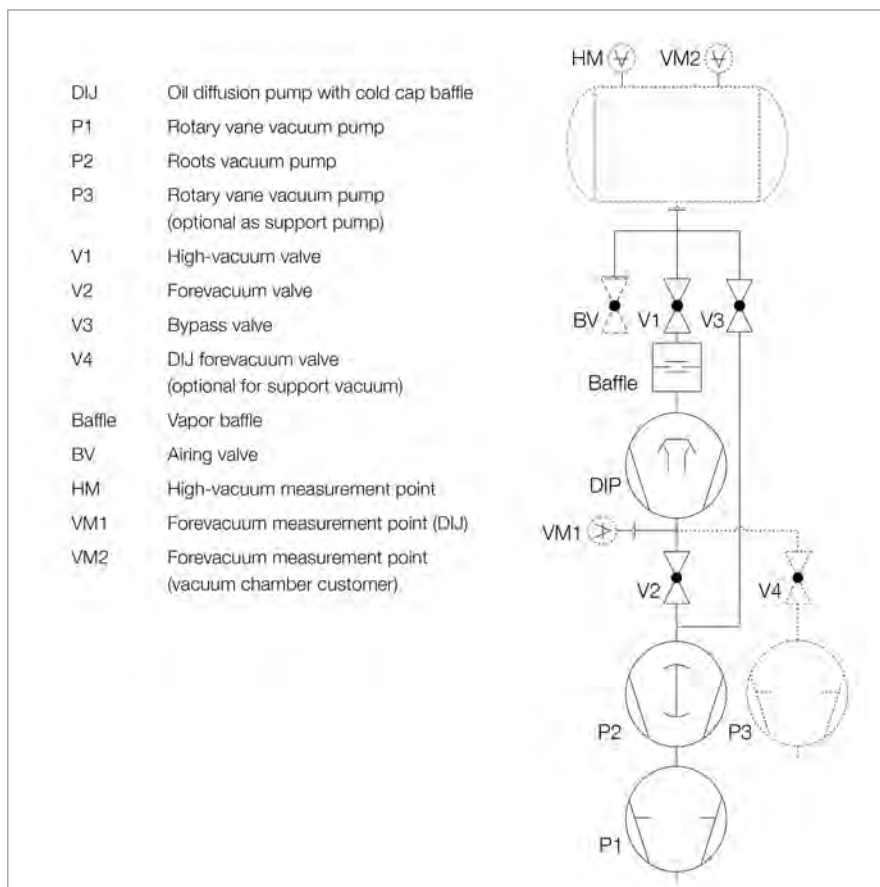

Schematic for a diffusion-type vacuum pump system

Attainable Ultimate Pressure

The attainable ultimate pressure for a particular vacuum system depends not only on the type and pumping speed rating of the diffusion pump, but also on the vapor pressure of the pump fluid, shape and temperature of the baffle, leaks at connecting flanges or welded joints and the condition of the surfaces within the vacuum chamber.

When excluding all effects which contribute to an increase in pressure within the

Sealing Methods

For ultimate pressures down to 10^{-8} mbar (0.75×10^{-8} Torr) bakeout temperatures of up to 150 °C (302 °F) are sufficient. FPM [FKM (= Fluor caoutchouc), temperature resistant up to 150 °C (302 °F)] sealing rings or ultra sealing rings made of aluminum must be used.

In order to prevent pressure variations, ultra sealing rings must be used in the connections, between diffusion pump and baffle.

vacuum chamber due to leaks and contamination of the vacuum chamber walls, it will be possible to attain the ultimate pressures stated in the table "Attainable Ultimate Pressures with Oil Diffusion Pumps (DIP)" given in chapter "General".

In practice the following combination has been found to work very well when needing a low vacuum free of oil vapors.

Ultimate pressures below 10^{-8} mbar (0.75×10^{-8} Torr) require bakeout temperatures up to 400 °C (752 °F). However, it is only necessary to bake out the vacuum chamber to 400 °C (752 °F) and to maintain a temperature gradient across the baffle or the cold trap so that a temperature of 150 °C (302 °F) is not exceeded at the intake flange of the pump.

In this way, it is still acceptable to use FPM (FKM) sealing rings or ultra sealing rings made of aluminium.

- Water-cooled cold cap baffle as an integral part of the diffusion pump together with a water-cooled Astrotorus baffle which may be installed as an additional component on the high vacuum flange of the diffusion pump.

Cooling

The cooling water temperature should not exceed 25 °C (77 °F) at the intake and 30 °C (86 °F) at the discharge, otherwise sufficient condensation of the pump fluid cannot be ensured. When connecting the cooling system of the pump and the baffle in series, the cooling water must always be made to flow through the baffle first and then through the diffusion pump, because the attainable ultimate pressure in the vacuum chamber depends strongly on the condensation temperature of the pump fluid in the baffle.

Attainable Ultimate Pressures with Oil Diffusion Pumps

Attainable Ultimate Pressure ¹⁾

LEYBONOL LVO 500

Without baffle	mbar (Torr)	1.5×10^{-6} (1.1×10^{-6})
With cold cap baffle	mbar (Torr)	5.0×10^{-7} (3.8×10^{-7})
With Astrotorus baffle	mbar (Torr)	1.5×10^{-7} (1.1×10^{-7})

¹⁾ Attained in consideration of the notes given under "Sealing Methods" in the chapter "General" para. "Oil Diffusion Pumps" and after degassing the connected vacuum chamber for several hours at 200 °C (392 °F)

Products

DIP Pumps, Water-Cooled



DIP 12 000



DIP 20 000 with Energy Efficiency Controller

The DIP range of pumps was developed for operation in industrial systems. Excellent vacuum performance data combined with the inherent ruggedness of this kind of pump, make our diffusion pumps a reliable component in high and medium vacuum applications.

Advantages for the User

- High pumping speeds in the fine and high vacuum ranges
- Low attainable ultimate pressure
- Integrated, water-cooled cold cap baffle guarantees low oil backstreaming rates into the vacuum chamber
- Low oil losses (even at high gas throughputs) by integrated water-cooled forevacuum baffle
- High forevacuum resistance even at reduced heating power
- The heating cartridges are accessible from the outside via heating inserts which are built into the boiler. This ensures a quick exchange of single heating cartridges (even when the pump is hot)
- A separate automatic circuit breaker for each heating cartridge ensures a high level of electrical safety
- A standard built-in thermostat acts as a thermal overload switch and ensures that the heating cartridges can not overheat
- All pumps are prepared for installation with an over-temperature switch (optional) for checking the cooling water circuit, and a contact thermometer (optional) to monitor the operating temperature of the diffusion pump
- Indication of the oil level by sightglass permits simple checking of the current oil level
- All DIP pumps are delivered with their inside chamber cleaned in such a manner that it is free of oil. The inside is evacuated. In the condition as delivered, the pumps may be also operated with silicone oil
- Utilisation of the DIP energy efficiency controller cuts power consumption by up to 30% without impairing pump performance (option)

Typical Applications

The diffusion pumps from the DIP range are used in coating systems, vacuum melting and drying systems as well as in vacuum furnaces in the area of metallurgy.

Supplied Equipment

The DIP pumps are supplied ready for connection but without the filling of pump fluid.

The inside of the pump is cleaned before delivery to such an extent that it is free of oil. The inside is evacuated. High and forevacuum flanges are equipped with gaskets and centering rings having shipping flanges and complete with clamping components.

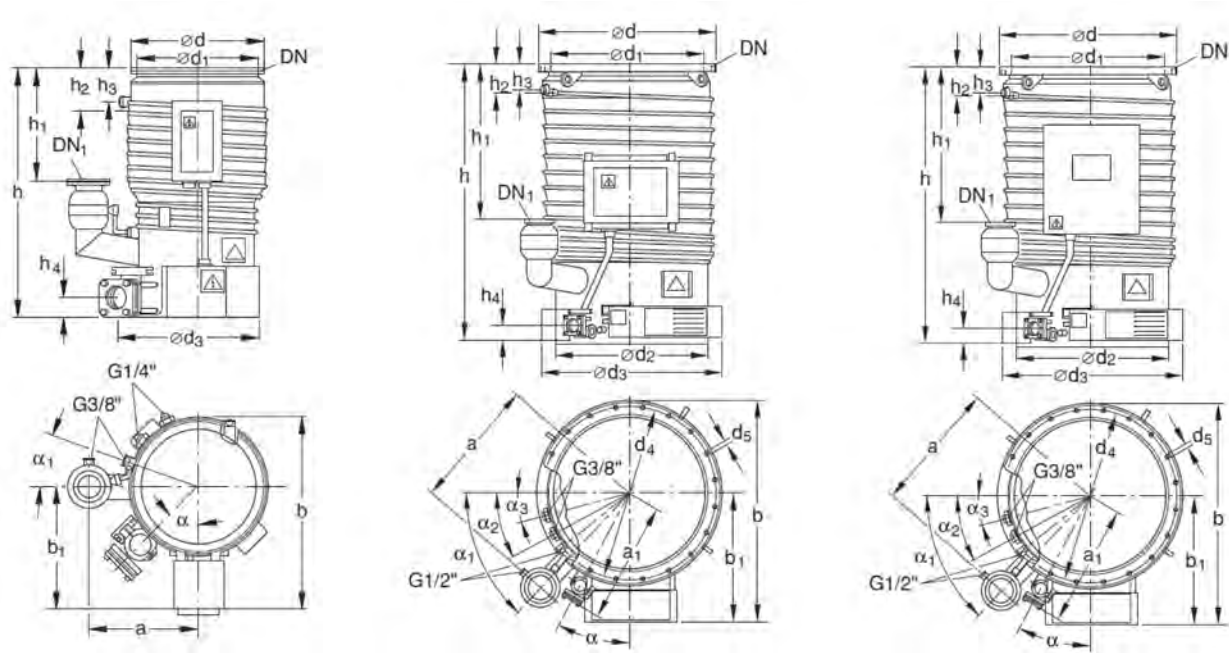

DIP	3 000	8 000	12 000	20 000	30 000	50 000
DN	250 ISO-K	400 ISO-K	500 ISO-K	630 ISO-F	800 ISO-F	1000 ISO-F
DN ₁	63 ISO-K	63 ISO-K	100 ISO-K	100 ISO-K	160 ISO-K	160 ISO-K
a	240 (9.45)	350 (13.78)	420 (16.54)	540 (21.26)	600 (23.62)	800 (31.5)
a ₁	250.5 (9.86)	375.5 (14.78)	432 (17)	496 (19.53)	536 (21.10)	636 (25.04)
b	443 (17.44)	643 (25.31)	775 (30.51)	980 (38.58)	1150 (45.28)	1350 (53.15)
b ₁	276 (10.87)	373 (14.69)	460 (18.11)	600 (23.62)	690 (27.17)	790 (31.10)
d	290 (11.42)	450 (17.72)	550 (21.65)	750 (29.53)	920 (36.22)	1120 (44.09)
d ₁	261 (10.28)	400 (15.75)	50119.72)	651 (25.63)	800 (31.5)	1000 (39.37)
d ₂	-	405 (15.94)	506 (19.92)	636 (25.04)	716 (28.19)	916 (36.06)
d ₃	278 (10.94)	530 (20.87)	630 (24.80)	760 (29.92)	840 (33.07)	1040 (40.94)
d ₄	-	-	-	720 (28.35)	890 (35.04)	1090 (42.91)
d ₅	-	-	-	14 (0.55)	14 (0.55)	14 (0.55)
Quantity of holes	-	-	-	20	24	32
h	560 (22.05)	785 (30.91)	940 (37)	1130 (44.49)	1450 (57.09)	1880 (74.02)
h ₁	250 (9.84)	400 (15.75)	470 (18.5)	620 (24.41)	870 (34.25)	1275 (50.2)
h ₂	68 (2.68)	88 (3.46)	92 (3.62)	97 (3.82)	102 (4.02)	102 (4.02)
h ₃	75 (2.95)	102 (4.02)	106 (4.17)	110 (4.33)	116 (4.57)	116 (4.57)
α	45°	30°	30°	30°	20°	25°
α ₁	20°	45°	45°	45°	45°	45°
α ₂	-	30°	30°	30°	30°	25°
α ₃	-	15°	15°	15°	15°	15°

Dimensional drawing for the DIP 3000 [left], DIP 8000 and DIP 12000 [middle], DIP 20 000 to DIP 50 000 [right]; dimensions in brackets () are in inch

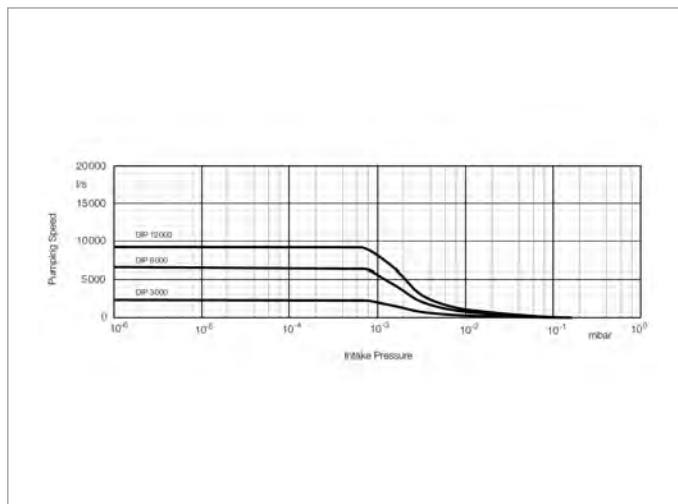

Pumping speed characteristics of the DIP 3000 to 12000 pumps as a function of intake pressure

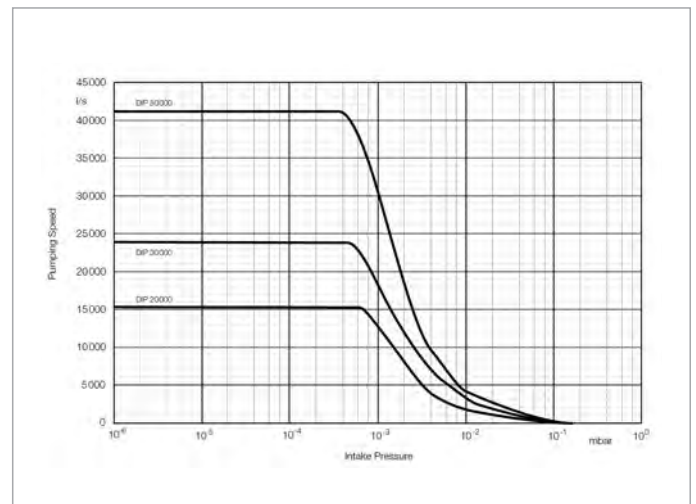

Pumping speed characteristics of the DIP 20000 to 50000 pumps as a function of intake pressure

Technical Data		DIP 3000	DIP 8000	DIP 12000
High vacuum / forevacuum connection	DN	250 ISO-K/63 ISO-K	400 ISO-K/63 ISO-K	500 ISO-K/100 ISO-K
Pumping speed ¹⁾ for				
Hydrogen < 1 x 10 ⁻⁴ mbar	l/s	3 000	8 000	12 000
Air < 1 x 10 ⁻⁴ mbar	l/s	2 200	6 500	8 900
Operating range	mbar (Torr)	< 10 ⁻² to 10 ⁻⁷ (0.75 x 10 ⁻² to 0.75 x 10 ⁻⁷)		
Ultimate total pressure ¹⁾	mbar (Torr)	< 5.0 x 10 ⁻⁷ (3.75 x 10 ⁻⁷)		
Max. permissible forevacuum pressure	mbar (Torr)	6.0 x 10 ⁻² (4.5 x 10 ⁻²)		
Pump fluid filling, min. / max.	l (qts)	2 / 2.5 (2.11 / 2.64)	4.5 / 5.5 (4.75 / 5.8)	8 / 9.5 (8.45 / 10)
Mains connection				
Standard EURO, 50/60 Hz	V	230 ~ 1 Ph	400 ~ 3 Ph Y	400 ~ 3 Ph Y
Standard Americas, 50/60 Hz	V	230 ~ 1 Ph	460 ~ 3 Ph Y	460 ~ 3 Ph Y
Special, 50/60 Hz	V	-	230 ~ 3 Ph Δ	230 ~ 3 Ph Δ
Heating power	kW	2.4	4.8	7.2
Number of heating cartridges		2	6	9
Warm-up period	min	< 25		
Coolant (minimum) for pump ²⁾	l/h (gal/min)	160 (0.7)	290 (1.28)	500 (2.2)
for cold cap baffle	l/h (gal/min)	20 (0.09)	30 (0.13)	50 (0.22)
max. supply pressure	bar (psig)	6 (87)	6 (87)	6 (87)
Number of cooling circuits (including cold cap baffle)		2		
Cooling water consumption for pump	G (BPS)	3/8"	1/2"	1/2"
for cold cap baffle	G (BPS)	1/4"	3/8"	3/8"
Weight, approx.	kg (lbs)	29 (64)	70 (154)	102 (225)
Recommended backing pump ³⁾ at operating pressures > 10 ⁻⁴ mbar (> 0.75 x 10 ⁻⁴ Torr)		TRIVAC D 65 B + W 251	SV 300 + W 251	SV 300 + W 501
at operating pressures < 10 ⁻⁴ mbar (< 0.75 x 10 ⁻⁴ Torr)		-	TRIVAC D 65 B + W 251	TRIVAC D 65 B + W 251

Ordering Information

DIP 3000

DIP 8000

DIP 12000

	Part No.	Part No.	Part No.
Oil diffusion pump with Circuit Breaker Box			
400 V / 50/60Hz / 3ph	-	222 20	222 25
460 V / 50/60Hz / 3ph	-	500 670	500 591
230 V / 50/60Hz / 1ph	222 10	-	-
230 V / 50/60Hz / 3ph	-	500 649	-
Other non-standard variants	on request	on request	on request
Astrotorus baffle	227 50	227 60	227 65
Over-temperature protection switch		122 84	
Contact thermometer		218 81	
Thermal insulation	-	-	6524072
Pump fluid ⁴⁾	see Catalog Part "Oils / Greases / Lubricants LEYBONOL"		

¹⁾ Measured to DIN 28 427 with LEYBONOL LVO 500 as the pump fluid

²⁾ The required quantity of cooling water refers to ΔT = 10 °C (50 °F). The discharge temperature should not exceed 30 °C (86 °F)

³⁾ Single- or two-stage rotary vane vacuum pump (TRIVAC; SOGEVAC) from our range of forevacuum pumps jointly with Roots vacuum pumps (RUVAC) in pump systems

⁴⁾ Oil must be purchased separately

Technical Data		DIP 20000	DIP 30000	DIP 50000
High vacuum / forevacuum connection	DN	630 ISO-F / 100 ISO-K	800 ISO-F / 160 ISO-K	1000 ISO-F / 160 ISO-K
Pumping speed ¹⁾ for Hydrogen < 1 x 10 ⁻⁴ mbar Air < 1 x 10 ⁻⁴ mbar	l/s l/s	20 000 16 000	30 000 24 500	50 000 41 000
Operating range	mbar (Torr)	< 10 ⁻² to 10 ⁻⁷ (0.75 x 10 ⁻² to 0.75 x 10 ⁻⁷)		
Ultimate total pressure ¹⁾	mbar (Torr)	< 5.0 x 10 ⁻⁷ (3.75 x 10 ⁻⁷)		
Max. permissible forevacuum pressure	mbar (Torr)	6.0 x 10 ⁻² (4.5 x 10 ⁻²)		
Pump fluid filling, min. / max.	l (qts)	9.5 / 12 (10 / 12.7)	12.5 / 14.5 (13.2 / 15.3)	19 / 24 (20 / 25.4)
Mains connection				
Standard EURO, 50/60 Hz	V	400 ~ 3 Ph Y		
Standard Americas, 50/60 Hz	V	460 ~ 3 Ph Y		
Special, 50/60 Hz	V	230 ~ 3 Ph Δ		
Heating power	kW	12	18	24
Number of heating cartridges		12	18	24
Warm-up period	min	< 25	< 30	< 30
Coolant (minimum) for pump ²⁾ for cold cap baffle max. supply pressure	l/h (gal/min) l/h (gal/min) bar (psig)	600 (2.6) 60 (0.26) 6 (87)	900 (4.0) 80 (0.35) 6 (87)	1500 (6.6) 150 (0.66) 6 (87)
Number of cooling circuits (including cold cap baffle)		2	3	3
Cooling water consumption for pump for cold cap baffle	G (BPS) G (BPS)	1/2" 3/8"		
Weight, approx.	kg (lbs)	172 (379)	296 (653)	560 (1235)
Recommended backing pump ³⁾ at operating pressures > 10 ⁻⁴ mbar (> 0.75 x 10 ⁻⁴ Torr) at operating pressures < 10 ⁻⁴ mbar (< 0.75 x 10 ⁻⁴ Torr)	kg(lbs)	SV 300 + W 501 TRIVAC D 65 B + W 251	SV 300 + W 1001 SV 300 + W 251	SV 630 B + W 2001 SV 300 + W 501

Ordering Information	DIP 20000	DIP 30000	DIP 50000
	Part No.	Part No.	Part No.
Oil diffusion pump with Circuit Breaker Box 400 V / 50/60Hz / 3ph 460 V / 50/60Hz / 3ph	222 30 500 882	222 35 500 665	222 40 500 728
with Energy Efficiency Controller 400 V / 50/60Hz / 3ph 460 V / 50/60Hz / 3ph	22230V001 22230V002	22235V001 22235V002	22240V001 22240V002
with Harting plug 460 V / 50/60Hz / 3ph	22230V006 on request	22235V006 on request	22240V006 on request
Astrotorus baffle	227 70	227 75	227 80
Over-temperature protection switch		122 84	
Contact thermometer		218 81	
Thermal insulation	6524070	6529302	6529303
Pump fluid ⁴⁾	see Catalog Part "Oils / Greases / Lubricants LEYBONOL"		

¹⁾ Measured to DIN 28 427 with LEYBONOL LVO 500 as the pump fluid

²⁾ The required quantity of cooling water refers to ΔT = 10 °C (50 °F). The discharge temperature should not exceed 30 °C (86 °F)

³⁾ Single- or two-stage rotary vane vacuum pump (TRIVAC; SOGEVAC) from our range of forevacuum pumps jointly with Roots vacuum pumps (RUVAC) in pump systems

⁴⁾ Oil must be purchased separately

DIP Pumps, Water-Cooled



DIJ 20 with plug (right), DIJ 20 with fuse box (middle) and DIJ 630 with energy saving unit (EER) (right)

The Leybold oil diffusion pumps are ideal for all industrial high vacuum applications.

The DIJ series impresses with innovative and energy-efficiency construction.

Important features are a new heating conception; variable flange connections; fully equipped with fore line baffle and cold cap baffle; electrical connect variants and a powerful five stage nozzle system.

Advantages for the User

- Lowest operation costs by minimized energy consumption
- Stable throughput in the 10^{-2} to 10^{-3} mbar range (e.g. for sputtering or steel degassing)
- Flexible flange design
Flange variants:
 - ANSI / Inch flanges (with O-ring)
 - ISO-F or ISO-K flanges (with centering ring)
- Highest system uptime
- Smart temperature control ensures minimum load and longest lifetime for heaters and oil
- Unique baffle design
- Various electrical connection possibilities:
 - Three different connection variants available incl. energy control system (ECU)
- 4 + 1 stage system design:
 - The 4 diffusion pump stages provide excellent high-vacuum pumping speed
 - The additional jet-stage ensures stable throughput at pressures $> 10^{-3}$ mbar

Typical Applications

The diffusion pumps from the DIP range are used in coating systems, vacuum melting and drying systems as well as in vacuum furnaces in the area of metallurgy.

Supplied Equipment

All DIJ pumps are shipped from the factory without pump fluid installed.

Included as standard equipment with the pump are

- centering ring with centering star, O-ring and outer ring for the highvacuum flange,
- centering ring with insert for forevacuum baffle, O-ring and outer ring for the forevacuum flange.

The high-vacuum and forevacuum flanges are closed with shipping flanges and claws. The insides of the pumps have been cleaned; they are evacuated prior to shipment.

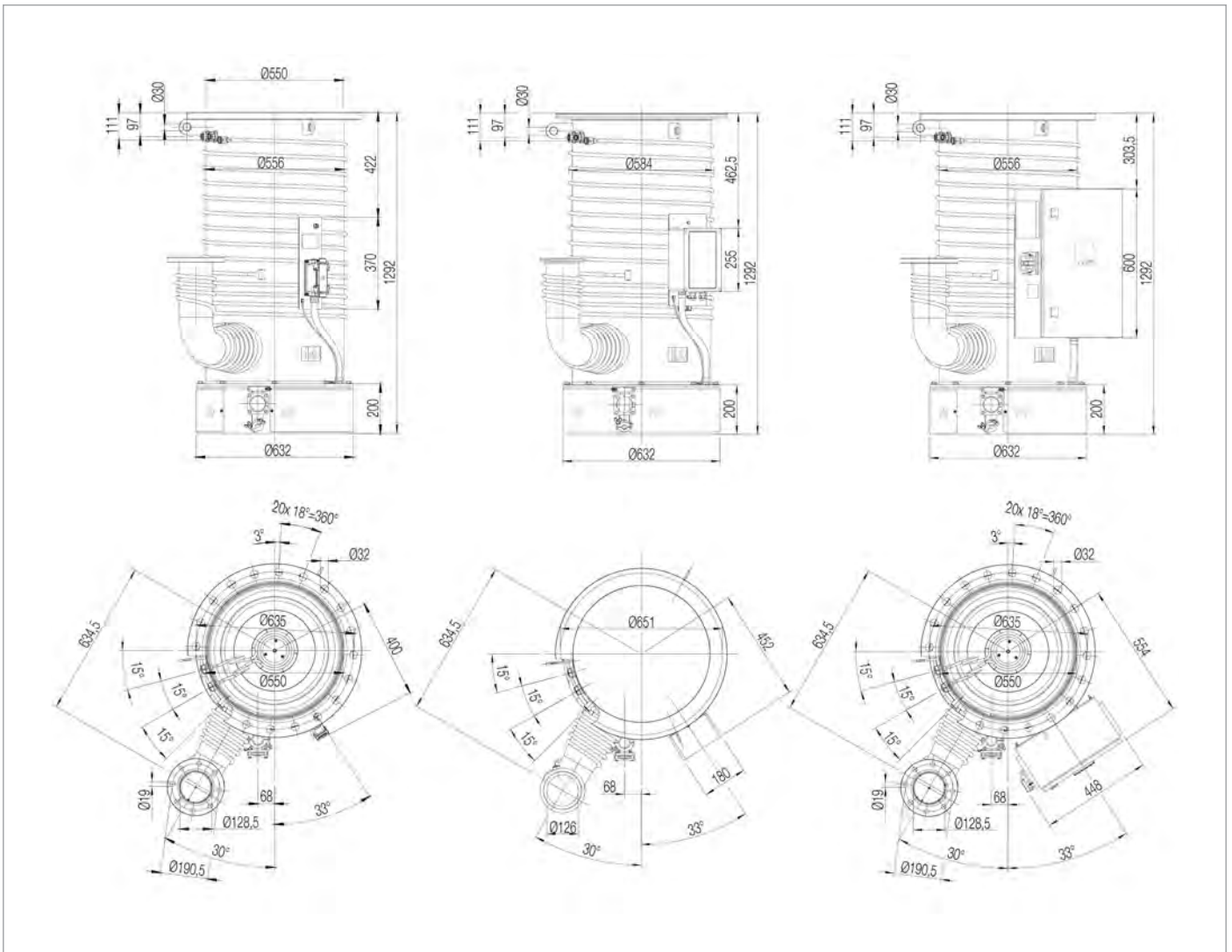

Dimensional drawings for DIJ 20 with plug, (left), DIJ 20 with ESU (middle) and DIJ 630 with junction box (EER) (right)

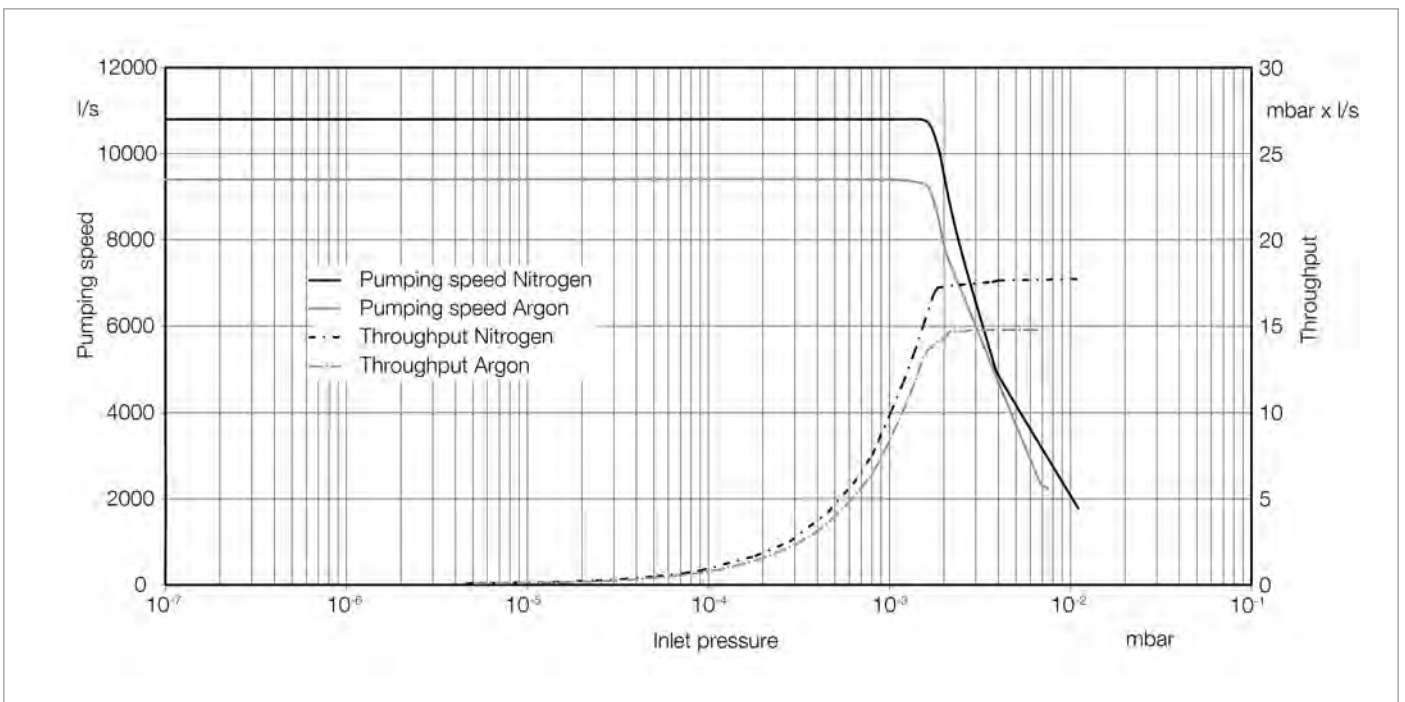

Pumping speed overview for nitrogen and argon

Technical Data

		DIJ 10	DIJ 320	DIJ 16	DIJ 500	DIJ 20	DIJ 630
High vacuum connection	DN	10" ANSI	320 ISO-K	16"ANSI	500 ISO-K	20" ANSI	630 ISO-K
Fore vacuum connection	DN	2" ANSI	63 ISO-K	3"ANSI	100 ISO-K	4" ANSI	160 ISO-K
Pumping speed ¹⁾ for Air < 8 x 10 ⁻⁴ mbar Argon < 10 ⁻⁴ mbar		3 000 2 750		6 800 6 350		10 800 9 500	
Operating range	mbar	< 10 ⁻¹ to 10 ⁻⁷		< 10 ⁻¹ to 10 ⁻⁷		< 10 ⁻¹ to 10 ⁻⁶	
Ultimate total pressure ²⁾	mbar	< 5 x 10 ⁻⁷		< 5 x 10 ⁻⁷		< 1 x 10 ⁻⁶	
Max. permissible forevacuum pressure	mbar	0.5		0.5		0.5	
Pump fluid fill, min. / max.	l	3.0 - 4.0		3.5 - 4.5		5.5 - 7.0	
Mains voltage depending on variant, 50 / 60 Hz	V V	3 ~ 400 V /N/PE 3 ~ 460 V /N/PE		3 ~ 400 V /N/PE 3 ~ 460 V /N/PE		3 ~ 400 V /N/PE 3 ~ 460 V /N/PE	
Heating power	kW	3.6		7.2		10.8	
Number of heating cartridges		3		6		9	
Warm-up period	min	< 15		< 15		< 25	
Coolant (minimum) ²⁾ for the pump for the cold cap baffle	l/h l/h	500 80		700 80		900 80	
Number of cooling circuits (including cold cap baffle)		2		2		3	
Coolant connection for the pump for the cold cap baffle	G l/h	3/8" 1/4"		1/2" 3/8"		1/2" 3/8"	
Weight, approx.	kg	95		152		230	
Recom. forevacuum pumps ³⁾ at operating pressure > 10 ⁻⁴ at operating pressure > 10 ⁻⁴	mbar mbar	SV 120 & W 1001 DV 300 & W 501		SV 200 & W 501 DV 300 & W 1001		SV 300 & WAU 1001 DV 450 & WAU 1001	
Recommended supporting pump ³⁾		D 40 B		D 40 B		D 65 B	

¹⁾ Measured as per DIN 28 427 using LVO 520 as the pump fluid.

²⁾ The coolant water volume is referenced to $\Delta T = 10$ K. The discharge temperature should not exceed 30 °C.

³⁾ Single- and two-stage rotary vane pumps (TRIVAC; SOGEVAC), or dry-compressing pumps (DRYVAC) from our line of forevacuum pumps in conjunction with roots pumps (RUVAC) in pumping systems.

Ordering Information

	DIJ 10	DIJ 320	DIJ 16	DIJ 500	DIJ 20	DIJ 630
	Part No.	Part No.	Part No.	Part No.	Part No.	Part No.
Oil diffusion pump with Circuit Breaker Box 400 V / 50/60Hz / 3ph 460 V / 50/60Hz / 3ph	22213V005 22213V006	22214V005 22214V006	22223V005 22223V006	22224V005 22224V006	22227V005 22227V006	22228V005 22228V006
with Energy Efficiency Controller (EEC) 400 V / 50/60Hz / 3ph 460 V / 50/60Hz / 3ph	- -	- -	- -	- -	22227V009 22227V010	22228V009 22228V010
with Harting plug 400 V / 50/60Hz / 3ph 460 V / 50/60Hz / 3ph	22213V000 22213V001	22214V000 22214V001	22223V000 22223V001	22224V000 22224V001	22227V000 22227V001	22228V000 22228V001
with Harting plug for EEC 400 V / 50/60Hz / 3ph 460 V / 50/60Hz / 3ph	- -	- -	- -	- -	22227V002 22227V003	22228V002 22228V003
Other non-standard variants	on request	on request	on request	on request	on request	on request
Pump fluid ⁴⁾	see Catalog Part "Oils / Greases / Lubricants LEYBONOL"					

⁴⁾ Oil must be purchased separately

Technical Data

		DIJ 32	DIJ 800	DIJ 35	DIJ 1000
High vacuum connection	DN	32" ANSI	800 ISO-K	35"ANSI	1000 ISO-K
Fore vacuum connection	DN	6" ANSI	200 ISO-K	6"ANSI	200 ISO-K
Pumping speed ¹⁾ for Air < 8 x 10 ⁻⁴ mbar Argon < 10 ⁻⁴ mbar		21 000 18 000		33 000 26 000	
Operating range	mbar	< 10 ⁻¹ to 10 ⁻⁶		< 10 ⁻¹ to 10 ⁻⁶	
Ultimate total pressure ²⁾	mbar	< 1 x 10 ⁻⁶		< 1 x 10 ⁻⁶	
Max. permissible forevacuum pressure	mbar	0.5		0.5	
Pump fluid fill, min. / max.	l	9.0 / 11.0		9.0 / 11.0	
Mains voltage depending on variant, 50 / 60 Hz	V V	3 ~ 400 V /N/PE 3 ~ 460 V /N/PE		3 ~ 400 V /N/PE 3 ~ 460 V /N/PE	
Heating power	kW	21.5		21.5	
Number of heating cartridges		18		18	
Warm-up period	min	< 25		< 25	
Coolant (minimum) ²⁾ for the pump for the cold cap baffle	l/h l/h	900 80		900 80	
Number of cooling circuits (including cold cap baffle)		3		3	
Coolant connection for the pump for the cold cap baffle	G l/h	1/2" 3/8"		1/2" 3/8"	
Weight, approx.	kg	570		610	
Recom. forevacuum pumps ³⁾ at operating pressure > 10 ⁻⁴ at operating pressure > 10 ⁻⁴	mbar mbar	SV 630 & W 2001 DV 650 & W 2001		SV 630 & W 2001 DV 650 & W 2001	
Recommended supporting pump ³⁾		D 65 B		D 65 B	

¹⁾ Measured as per DIN 28 427 using LVO 520 as the pump fluid.

²⁾ The coolant water volume is referenced to $\Delta T = 10$ K. The discharge temperature should not exceed 30 °C.

³⁾ Single- and two-stage rotary vane pumps (TRIVAC; SOGEVAC), or dry-compressing pumps (DRYVAC) from our line of forevacuum pumps in conjunction with roots pumps (RUVAC) in pumping systems.

Ordering Information

	DIJ 32	DIJ 800	DIJ 35	DIJ 1000
	Part No.	Part No.	Part No.	Part No.
Oil diffusion pump				
with Circuit Breaker Box				
400 V / 50/60Hz / 3ph	22237V005	22238V005	22243V005	22244V005
460 V / 50/60Hz / 3ph	22237V006	22238V006	22243V006	22244V006
with Energy Efficiency Controller (EEC)				
400 V / 50/60Hz / 3ph	22237V009	22238V009	22243V009	22244V009
460 V / 50/60Hz / 3ph	22237V010	22238V010	22243V010	22244V010
with Harting plug				
400 V / 50/60Hz / 3ph	22237V000	22238V000	22243V000	22244V000
460 V / 50/60Hz / 3ph	22237V001	22238V001	22243V001	22244V001
with Harting plug for EEC				
400 V / 50/60Hz / 3ph	22237V002	22238V002	22243V002	22244V002
460 V / 50/60Hz / 3ph	22237V003	22238V003	22243V003	22244V003
Other non-standard variants	on request	on request	on request	on request
Pump fluid ⁴⁾	see Catalog Part "Oils / Greases / Lubricants LEYBONOL"			

⁴⁾ Oil must be purchased separately

Oil Booster OB 6000 to OB 18000



Oil Booster OB 6000 (left), OB 12000 (middle) and OB 18000 (right)

Advantages for the User

- Very high pumping speed from a small sized pump
- Pump sizes 6000, 12,000 and 18,000 m³ per hour
- Simple to operate
- Rugged and long life
- Selectable flange connections (OB 12,000 and 18,000 only)
- Small manageable amount of spare parts
- Pump components (e.g. heating elements, diffusion corpus, jet corpus) are similar for all OB sizes and can be exchanged easily
- Modern electronic pump monitoring (PLC controlled)
- High efficiency due to direct heating
- Optimized heating design for long oil change intervals

Typical Applications

- Vacuum Induction Melting (VIM) or Vacuum Induction Degassing (VID) of special alloys are utmost important process steps in the metallurgy.
- Depending on the required steel quality, the required process pressure in such applications is particularly low.
- Secondary metallurgy processes are becoming more popular thanks to the greater demand for better steels e.g. in the automotive, construction and rail markets.

The design of the oil booster pumps from Leybold is well proven in industrial high vacuum applications. They excel above all through excellent vacuum performance data and are, owing to their rugged design a reliable component in many medium and high vacuum units.

The water cooled oil booster pump was developed in particular for applications in the rough and medium vacuum range. The pumps from the OB line from Leybold deliver when properly deployed, a maximum pumping speed at high gas throughputs.

Supplied Equipment

The OB pumps are plug-and-play but are delivered without pump fluid. The pump chamber is free of oil and has been cleaned.

The inside volume is evacuated. The high vacuum and forevacuum flanges are equipped with sealing and centering rings as well as shipping flanges. Moreover, the electric circuit breaker box and the cooling water manifold have been installed for immediate connection.

The included Pt100 temperature sensor ensures safe oil temperature monitoring. The installed overtemperature protection switch monitors and ensures safe operation of the pump.

Technical Data		Oil Booster		
		OB 6000	OB 12000	OB 18000
Pumping speed for air 1.0×10^{-3} mbar (7.5 x 10 ⁻³ Torr)	mbar x l/s	6000	12000	18000
High vacuum connection standard optional	DN DN	400 ISO-K 400 ISO-K / ASA 16 / ASA 18	630 ISO-F 500 ISO-K / 800 ISO-F / ASA 16 / ASA 20	630 ISO-F 800 ISO-F / 1000 ISO-F / ASA 32 / ASA 35
Fore vacuum connection (standard)	DN	160 ISO-K		
Operating range	mbar (Torr)	1 to 10 ⁻⁶ (0.75 to 10 ⁻⁶)		
Ultimate total pressure	mbar (Torr)	5 x 10 ⁶ (< 3.75 x 10 ⁻⁶)		
Pump fluid filling	l (qts)	45 (47.6)	60 (63.4)	90 (95.1)
Mains connection Standard EURO, 50/60 Hz Standard Americas, 50/60 Hz Special, 50/60 Hz	V V V	400 ~ 3 Ph Y 460 ~ 3 Ph Y 230 ~ 3 Ph Δ		
Cooling water consumption connection	l/h (gal/min) G	700 (3.1) 1"	800 (3.5) 1"	1360 (6.0) 1"
Weight	kg (lbs)	450 (992)	850 (1874)	1400 (3086)

Ordering Information

	Oil Booster		
	OB 6000	OB 12000	OB 18000
	Part No.	Part No.	Part No.
Oil booster pump with Energy Efficiency Controller and Water Flow Sensor 400 V / 50/60Hz / 3ph 460 V / 50/60Hz / 3ph	503750V003 503750V004 on request	503654V003 503654V004 on request	503508V003 503508V004 on request
Other non-standard variants	on request		
Pump fluid	see Catalog Part "Oils / Greases / Lubricants LEYBONOL"		

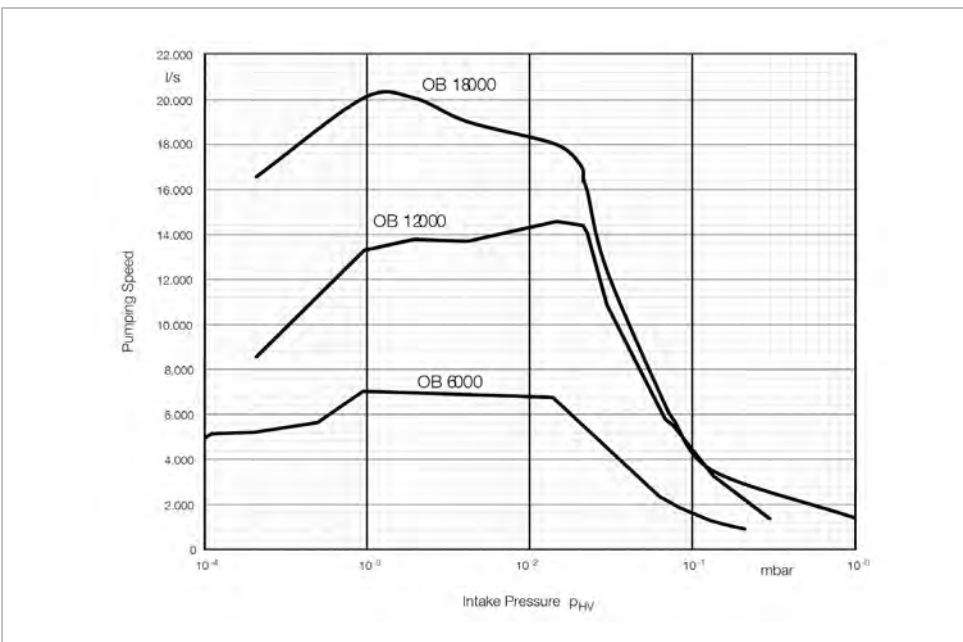

Pumping speed curves of the Oil Booster OB 6000 to OB 18000 as a function of the intake pressure

Accessories

Astrotorus Baffles

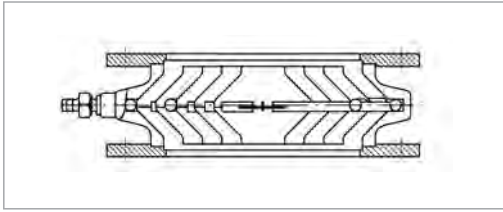

The cooling inserts of the astrotorus baffles are made of copper, whereas the housing and the connection flange are made of standard steel.

Section through an astrotorus baffle

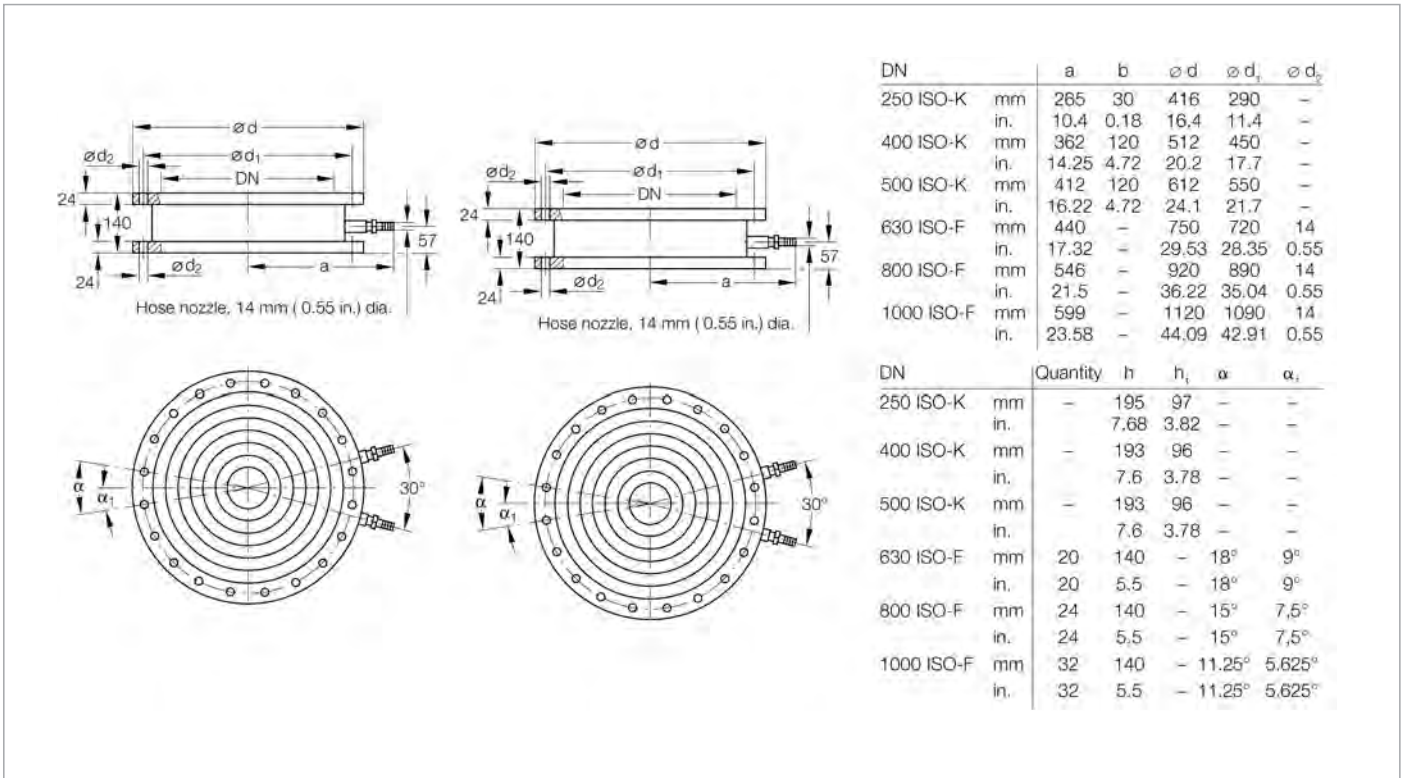

Dimensional drawing for the astrotorus baffle ISO-K (left) and ISO-F (right)

Technical Data		Astrotorus Baffles		
Connection to pump	DIP	3 000	8 000	12 000
HV connection flanges	DN	250 ISO-K	400 ISO-K	500 ISO-K
Throttling of the pumping speed, approx.	%	30		
Conductance	l/s	3000	9000	12000
Weight	kg (lbs)	25.0 (55.2)	30.0 (66.2)	65.0 (143.5)

Ordering Information		Astrotorus Baffles		
	Part No.	Part No.	Part No.	Part No.
Astrotorus Baffles				
250 ISO-K	227 50	-	-	-
400 ISO-K	-	227 60	-	-
500 ISO-K	-	-	-	227 65

Technical Data		Astrotorus Baffles		
Connection to pump	DIP	20 000	30 000	50 000
HV connection flanges	DN	630 ISO-F	800 ISO-K	1000 ISO-K
Throttling of the pumping speed, approx.	%	30		
Conductance	l/s	18 000	28 000	50 000
Weight	kg (lbs)	120.0 (264.9)	170.0 (375.3)	190.0 (419.4)

Ordering Information		Astrotorus Baffles		
	Part No.	Part No.	Part No.	Part No.
Astrotorus Baffles				
630 ISO-K	227 70	-	-	-
800 ISO-K	-	227 75	-	-
1000 ISO-K	-	-	-	227 80

For matching valves, please ask us for a quotation.

Temperature dependant Switching Components for Automatic Pump System Control

The operational status of the diffusion pump depends on the temperature of the pump fluid in the pump boiler. Through temperature dependent switching components which are inserted into the pump boiler it is possible to monitor the operational status of the diffusion pump and signal its status to a process controller.

For this, the diffusion pump requires two thresholds. Depending on the type of pump, the upper threshold should be between 180 and 200 °C (356 and 392 °F) and the lower threshold between 90 and 100 °C (194 and 212 °F)

The upper threshold indicates that the diffusion pump is ready for operation and thus actuates certain devices, for example opening of the high vacuum valve ahead of the diffusion pump.

The lower threshold indicates that the diffusion pump has cooled down to such an extent that the backing pump and the cooling water supply may be switched off.

Over-temperature protection

switches are used to monitor the temperature of the cooling water in the cooling water circuit of the diffusion pumps. When the temperature rises to unacceptably high levels (for example when the cooling water supply fails) the heater in the diffusion pump is switched off (correct electrical connection to the main supply is required). The use of over-temperature protection switches avoids unnecessary alarms that may be triggered by contaminated water when only a water flow monitor is used. The over-temperature protection switch is screwed on to a contact plate which is soldered to the cooling pipe on the pump's body.

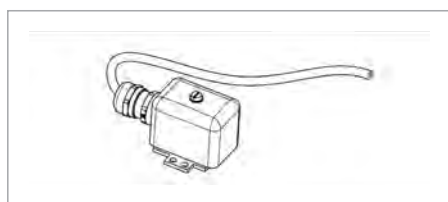

Over-temperature protection switch

Max. switching current: 5 A (230 V, 50/60 Hz).

Contact thermometer with a range from 0 to 400 °C (32 to 752 °F). Through a trailing pointer two switching thresholds may be set up independently. The current oil temperature and the thresholds which have been set up can be read off at the location of the diffusion pump. The contacting thermometer is not suited

for remote signaling of temperatures.

Resistance thermometer Pt100 sensor. The measurement range of this sensor depends on the temperature display unit used by the customer where also the required thresholds are set up. The Pt100 sensor is ideal for remote signaling of temperatures.

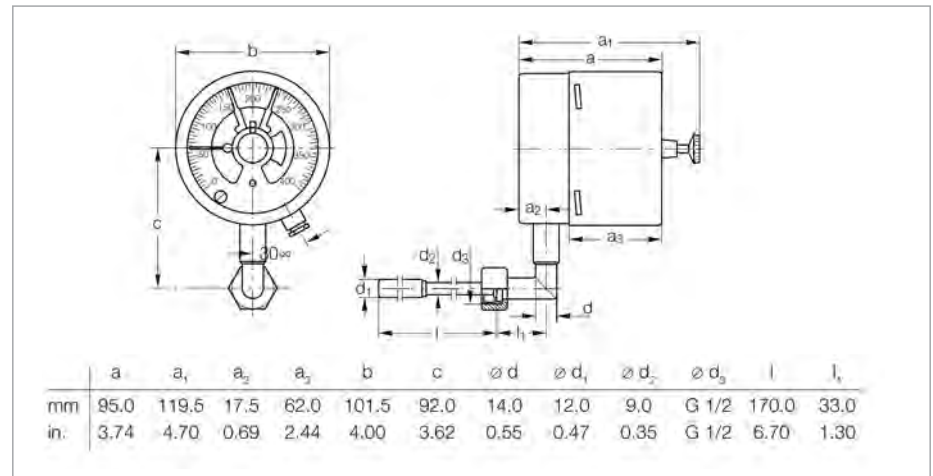

Dimensional drawing for the contact thermometer

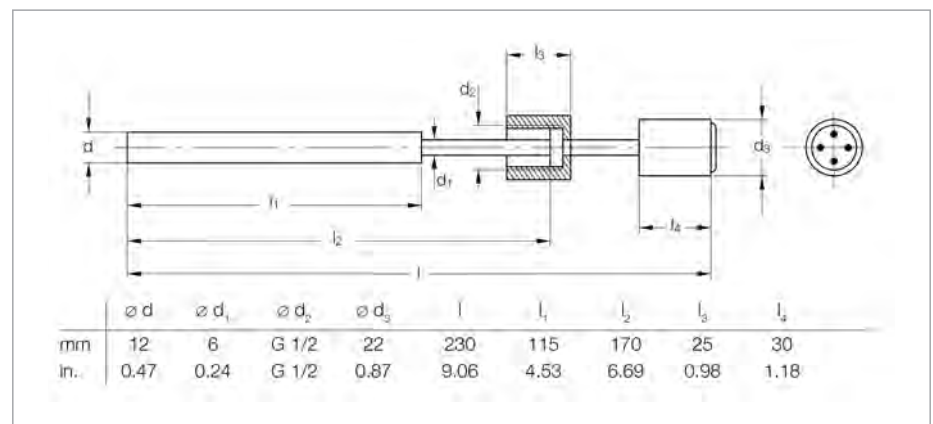

Dimensional drawing for the resistance thermometer Pt100 sensor

Ordering Information

Monitoring Instruments

	Part No.
Over-temperature protection switch	122 84
Contact thermometer (Measurement range 0 to +400 °C (+32 to +752 °F), Rating at 220 V AC: 250 mA [resistive load], Weight: 1.7 kg (3.7 lbs))	218 81
Resistance thermometer Pt100 sensor	200 02 958

Monitoring Instruments

Protection against Overheating

Water flow monitors are installed in the cooling water return section of the diffusion pump. When the cooling water throughput drops below a certain level, either the heater in the diffusion pump is switched off or a warning light or signal is triggered, depending of the type of circuit.

Measurement range: 1 to 40 l/min
(0.2 to 10.6 gal/min)

The water throughput may be set within the limits stated with a high degree of reproducibility.

Water flow monitors may be installed in any orientation.

Max. switching capacity:
100 VA (230 V, 50/60 Hz).

Protection against Power Failure

A SECUVAC valve (see Product Section "Vacuum Valves") must be installed in the forevacuum line in order to prevent damage to the diffusion pump or the pump fluid in the event of a power failure affecting backing pumps which are not equipped with an automatic isolation valve. Rotary vane vacuum pumps from the TRIVAC B series are equipped with an automatic Pressure relief valve (intake isolation valve) as standard.

Protection against Pressure Increases in the Forevacuum Line

For protection against a pressure increase in the forevacuum line which is not caused by a power failure you may use our vacuum gauges which offer an adjustable switching threshold (see Product Section "Vacuum - Measuring, Controlling").

Ordering Information

Water Flow Monitor

	Part No.
Water flow monitor	500006623

Energy Efficiency Controller



Energy efficiency controller with integrated USB interface



Ethernet interface for PLC data integration

When it comes to the aspect of economic and efficient operation of diffusion pumps, power consumption plays an important role. Through our DIP Energy Efficiency Controller (EEC), you may now drastically cut your power consumption – and this without impairing pump performance in any way.

Leybold provides an unique energy control unit with less thermal loss to control the heating power to save energy significantly.

Advantages for the User

- Energy saving up to 30% (low costs and ROI in less than three years)
- Further potential savings through temperature decrease in standby-mode
- High quality regulation with customized software
- Increased operation safety and comfort
- Improved service life for oil and heating cartridges
- Easy and exact to operate via PLC or manual directly at the pump
- Uncomplicated integration of generated data into your own process control or export data via USB port
- Strategically process analysis and optimization by interpretation of energy control unit data

Ordering Information

Energy efficiency controller for

DIP 12000

DIP 20000

DIP 30000

DIP 50000

**DIJ
with Harting
Plug for EEC**

	Part No.	Part No.	Part No.	Part No.	Part No.
Retrofit kit	503646V002	503647V001	503648V001	503649V001	-
EEC plug version	-	-	-	-	503646V001

Right-Angle Valves, DN 250 ISO-K to DN 1000 ISO-F, Electropneumatically Operated



Electropneumatically actuated rightangle valves are used in automated vacuum systems which need to be controlled electrically.

Advantages to the User

- Pneumatic or electropneumatic opening
- Short opening and closing times
- Optical position indicator
- Electric position indicator
- With and without pilot valve IP 54
- Protection class IP 50
- The valves are closed by the restoring force of a spring
- Installation in any orientation and no restrictions as to the direction of flow

Electropneumatically actuated right-angle valves, stainless steel, DN 250 ISO-K

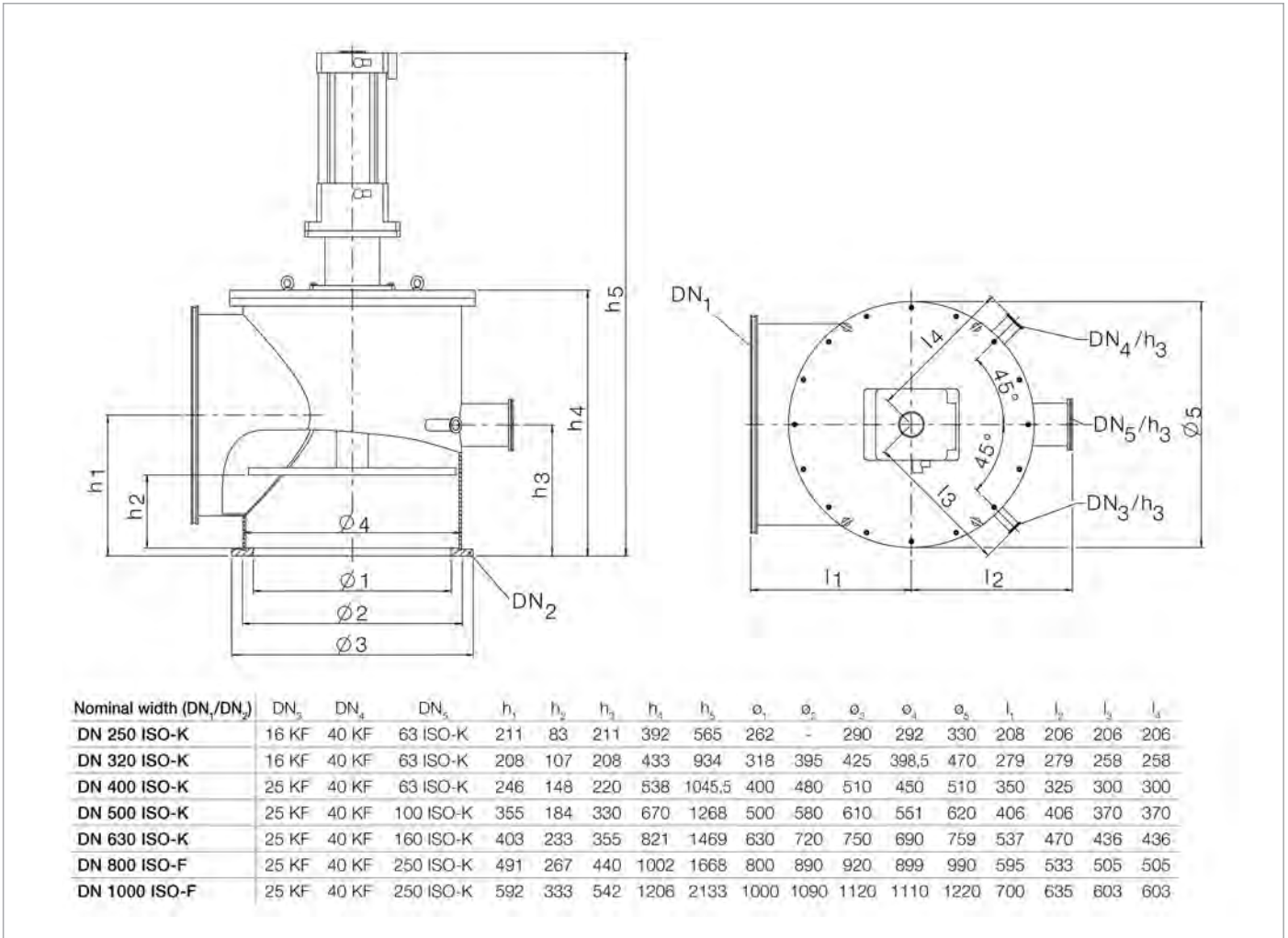

Dimensional drawing (all dimensions in mm)

Technical Data	DN 250	DN 320	DN 400	DN 500	DN 630	DN 800	DN1000
	ISO-K	ISO-K	ISO-K	ISO-K	ISO-K	ISO-F – F	ISO-F

Installation orientation	vertical / pneumatic Cylinder at the top						
Conductance	4,000	6,000	9,000	12,000	20,000	30,000	50,000
Weight (kg)	51	110	150	190	270	350	450
Drive pneumatic	(opening and closing)						
Pressure difference when opening	Max. 200 mbar						
Opening time ²⁾ (sec)	2	3	5	5	6	8	8
Closing time ²⁾ (sec)	2	3	5	5	6	8	8
Service life (actuations)	> 1 x 10 ⁵	> 1 x 10 ⁵	> 1 x 10 ⁵	> 1 x 10 ⁵	> 1 x 10 ⁵	> 5 x 10 ⁴	> 5 x 10 ⁴
Helium leak rate	< 1 x 10 ⁻⁷ mbar l/s						
Pressure range	1 x 10 ⁻⁷ mbar to atmospheric pressure						
Max operating temp.	60 °C						
Connecting flange ¹⁾	DN 250 ISO-K – K	DN 320 ISO-K – F	DN 400 ISO-K – F	DN 500 ISO-K – F	DN 630 ISO-K – F	DN 800 ISO-F – F	DN1000 ISO-F – F
Bypass Flange	63 ISO-K	63 ISO-K	63 ISO-K	100 ISO-K	160 ISO-K	250 ISO-K	250 ISO-K
Further Flanges	NW40 NW16	NW40 NW16	NW40 NW25	NW40 NW25	NW40 NW25	NW40 NW25	NW40 NW25

Materials

Housing and disk	Stainless steel 1.4301						
Seals	FKM						
Sealing bellows	Stainless steel 1.4373						
Pilot valve							
Nominal voltage	24 V DC						
Nom. power consumption	4,5 W						
Duty ratio	100 %						

End position switch (max. contact ratings)

Nominal voltage	5 – 240 V AC/DC						
Current	100 mA						
Power consumption	10 W						

Compressed air supply

Air connection	¼" NPT						
Pressure range	5 – 7 bar						

¹⁾ per flange, 12 clamping screws are needed for mounting (Part No. 267 10)

²⁾ under vacuum, differential pressure $\Delta p = 0$ and compressed air = 6 bar (overpressure)

Ordering Information	DN 250	DN 320	DN 400	DN 500	DN 630	DN 830	DN1000
	ISO-K	ISO-K	ISO-K	ISO-K	ISO-K	ISO-F – F	ISO-F

	Part No.	Part No.	Part No.	Part No.	Part No.	Part No.	Part No.
Right-angle valve, electropneumatic drive	504137V002	504138V002	504139V002	504140V002	504141V002	504142V002	504143V002
Seal kit with bellows	EK121870-00	EK121871-00	EK121872-00	EK121873-00	EK121874-00	EK121875-00	EK121876-00
Seal kit without bellows	EK121870-01	EK121871-01	EK121872-01	EK121873-01	EK121874-01	EK121875-01	EK121876-01
Electronics-solenoid and position indicators	EK121870-02	EK121871-02	EK121872-02	EK121873-02	EK121874-02	EK121875-02	EK121876-02

More valves please find in the catalog part "Valves"

General

Applications and Accessories, Cryo Pumps

Cryo pumps

High Vacuum Pumps

Applications	COOLVAC 1500 iSL/iBL	COOLVAC 2000 iSL/iBL	COOLVAC 3000 iSL/iBL	COOLVAC 5000 iSL/iBL	COOLVAC 10000 iSL/iBL	COOLVAC 18000 iSL/iBL	COOLVAC 30000 iSL/iBL	COOLVAC 60000 iSL/iBL	COOLVAC 30000 iLN ₂	COOLVAC 60000 iLN ₂
General research	■	■	■	■	■	■	■	■	■	■
Evaporation coating systems	■	■	■	■	■	■	■	■		
Transfer chambers / Loadlock	■	■	■	■	■	■				
Metallization systems	■	■	■	■	■	■	■	■		
Sputtering systems	■	■	■	■	■					
Electron beam welding systems	■	■	■	■	■	■				
Space simulation chambers	■	■	■	■	■	■	■	■	■	■
UHV systems	■	■	■							
Beam tubes in particle accelerators	■	■								
Vacuum furnaces				■	■	■	■	■	■	■

Model versions

iBasicLine iBL without electronics, with temperature sensor	■	■	■	■	■	■	■	■	■	■		
iSmartLine version with electronics and integrated controller, with temperature sensors and electrical heaters	■	■	■	■	■	■	■	■	■	■		
iLN2 version with liquid nitrogen cooling, temperature sensors and electrical heater											■	■

Accessories

Purge gas option	■	■	■	■	■								
Compressor unit COOLPAK 2000i Series	■	■	■										
Compressor unit COOLPAK 6000i Series	■	■	{ ■ }	■	■	■	■	■	■	■	■	■	■
Flexible pressure lines	■	■	■	■	■	■	■	■	■	■	■	■	■
Gas manifold GD 2 for multiple operation of up to two cryo pumps	■	■	■	■*)	■*)								
Gas manifold GD 4 for multiple operation of up to four cryo pumps	■	■	■										
Low temperature measuring instrument MODEL 211 S (iBasicLine Series only)	■	■	■	■	■	■	■	■	■	■	■	■	■

{ ■ } = For dual and multiple operation only *) Multiple operation only after consultation with technical support

Applications and Accessories, Cryogenics

Cold heads	single-stage				double-stage			
	COOLPOWER 25i	COOLPOWER 50i	COOLPOWER 140i T	COOLPOWER 250 MDi	COOLPOWER 7/25i	COOLPOWER 5/100i	COOLPOWER 10 MDi	COOLPOWER 4K LT
Applications								
Cooling of samples, sensors and detectors	■	■	■	■	■	■	■	
Cooling of detectors in astronomy	■	■	■	■	■	■	■	
Cooling of samples for spectroscopy				■	■	■		
Cooling of samples for applications in medical technology and R&D				■	■	■		
Cooling of HTS superconductors	■	■	■	■	■	■	■	
Cooling of LTS superconductors				{ ■ }	{ ■ }	{ ■ }	{ ■ }	
Cooling in medical equipment				■	■	■	■	
Cooling of surfaces for pumping of gases	■	■	■	■	■	■	■	■
Cryogenic process gas cleaning	■	■	■	■	■	■	■	■
Condensation, resublimation and freezing of gases	■	■	■	■	■	■	■	■

{ ■ } = Only LTS superconductors with $T_c > 10$ K

Accessories

Compressor unit COOLPAK 2000i Series	■	■			■		
Compressor unit COOLPAK 6000i Series		■	■	■	■	■	■
Low temperature measuring instrument MODEL 211S		■	■	■	■	■	■
Temperature sensor		■	■	■	■	■	■

{ ■ } = Only high T_c superconductors

Conversion of Units

Kelvin (K), Celsius (°C), Fahrenheit (°F)

Calculation from	Calculation to	Formula
Celsius	Fahrenheit	$^{\circ}\text{F} = ^{\circ}\text{C} \times 1.8 + 32$
Celsius	Kelvin	$\text{K} = ^{\circ}\text{C} + 273.15$
Kelvin	Celsius	$^{\circ}\text{C} = \text{K} - 273.15$
Kelvin	Fahrenheit	$^{\circ}\text{F} = \text{K} \times 1.8 - 459.67$
Fahrenheit	Celsius	$^{\circ}\text{C} = (^{\circ}\text{F} - 32) / 1.8$
Fahrenheit	Kelvin	$\text{K} = (^{\circ}\text{F} + 459.67) / 1.8$

The following applies to absolute zero:

$$0 \text{ K} = -273.15 \text{ } ^{\circ}\text{C} = -459.67 \text{ } ^{\circ}\text{F}.$$

Cryo Pumps

Cryo pumps are gas entrapment vacuum pumps for the pressure range from 10^{-3} to $\leq 10^{-11}$ mbar (0.75×10^{-3} to $\leq 0.75 \times 10^{-11}$ Torr). The principle of operation is that gaseous substances are bound to the cold surfaces within the pump by means of cryocondensation, cryosorption or cryotrapping.

In order to be able to produce a high or ultra-high vacuum, the cold surfaces (cryopanel) must be cooled to a sufficiently low temperature. refrigerator cooled cryo pumps are the most common pumps.

Leybold manufactures refrigeratorcooled cryo pumps as well as liquid nitrogen supported cryo pumps.

Advantages for the User

Advantages offered by the pumping principle

- High effective pumping speed for all gases
- Extremely high pumping speed for H_2O (water) and H_2 (hydrogen)

For a given diameter of the high vacuum flange, the cryopump offers the highest pumping speed of all high vacuum pumps.

Advantages offered by Design

In contrast to gas transfer high vacuum pumps, cryo pumps do not have any mechanically moving, oil or grease lubricated parts on the vacuum side.

The following advantages are a direct result of this design characteristic:

- Hydrocarbon-free vacuum in the pressure range from 10^{-3} to $\leq 10^{-11}$ mbar (0.75×10^{-3} to $\leq 0.75 \times 10^{-11}$ Torr).
- Insensitivity to mechanical disturbances from particles coming from the process or external vibrations

Further Advantages

- More compact than comparable pump systems offering a pumping speed of over 1500 l/s
- Backing pump is only required during start-up and during regeneration
- User friendly process control and pump control
- Favorable price-performance ratio and low running costs especially at higher pumping speeds

The cryo pumps are cooled by the well-proven two-stage refrigerators from Leybold's COOLPOWER i line (Gifford/McMahon principle).

The design of a refrigerator cryopump from the COOLVAC i range is shown schematically in the figure below.

The first stage of the cold head (6) cools the thermal radiation shield (7) and the baffle (8) of the pump.

Both are made of copper with high thermal conductivity in order to optimally utilize the available refrigerating capacity.

Operating temperatures of 45 K to 80 K are reached depending on the type of pump and on the operating conditions. Mainly water but also carbon oxides are pumped here.

The second stage of the cold head (9) is used to cool the cryopanel (10). These pumping surfaces are also made of copper of high thermal conductivity and they are tightly linked thermally to the second stage of the cold head.

Depending on the operating conditions, operating temperatures of 10 to 20 K are attained.

Here the process of cryocondensation of N_2 (nitrogen), O_2 (oxygen) and Ar (argon) will take place.

The inner part of the pumping surfaces are additionally covered with activated charcoal. Here the process of adsorption (cryosorption) of H_2 (hydrogen), Ne (neon) and He (helium) will take place.

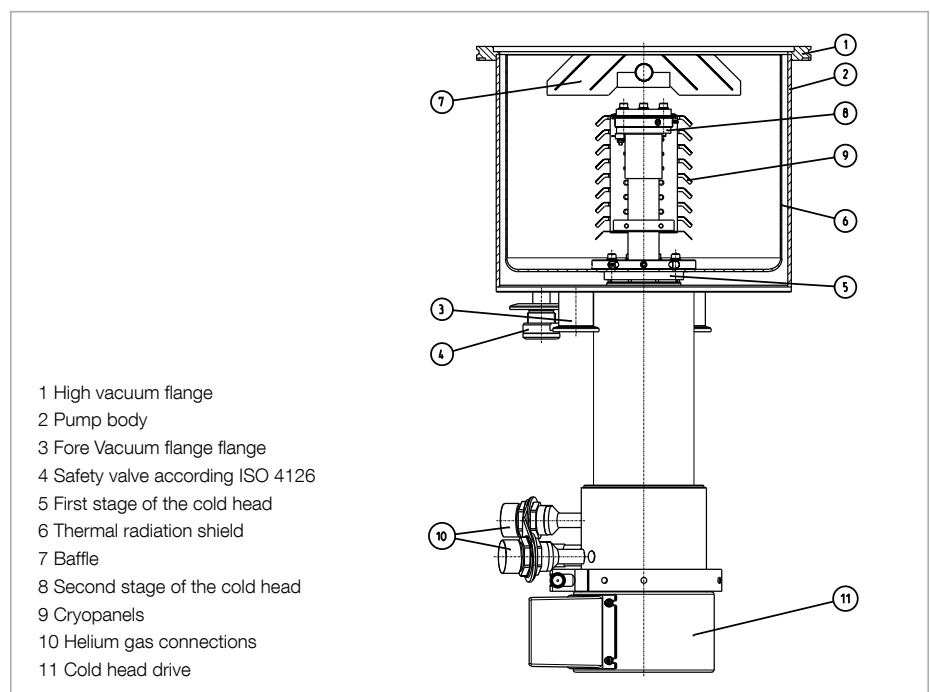

COOLVAC i refrigerator cryopump

All cryo pumps from the COOLVAC i range are equipped with all safety related components, especially with a safety valve according to ISO 4126 regulation.

The pump's body is made of high quality stainless steel.

Helium compressors from the COOLPAK range are required for operating the COOLPOWER cold heads, which are incorporated within the COOLVAC range of cryo pumps.

Regenerating Cryo Pumps

An important aspect of the operation of cryo pumps is that of regeneration. Since a cryo pump is a gas entrapment pump, the pumped gases must be removed from the pump before the capacity limit is exceeded.

The so-called "regeneration" occurs by switching off the compressor unit and heating up the cold surfaces to room temperature. The pumped gases are pumped out by means of a roughing pump. As soon as the vacuum pressure is low enough, the cryo pump can be cooled down again. Finally, when the operating temperature has been reached, the regeneration process is complete.

Various procedures are available for regeneration as listed below:

- Heating up through self-heating after the refrigerator has been switched off, and subsequent re-cooling
- Heating up with the support of a dry, warm inert gas
- Heating up by means of an electrical heater on the cold surfaces.

These methods can be combined with each other.

COOLVAC iSmartLine cryo pumps with regulated regeneration system

The cryo pumps from the iSmartLine (iSL) (*iCL*) range are gradually heated up to room temperature by means of electrical heaters at both cold head stages. Regeneration process, temperature and heating power are monitored and regulated via our COOL.DRIVE i controller at the cryo pump

During the process the pumped gases are released one after the other in the following sequence:

- Gases adsorbed at the cryopanel (e.g. hydrogen, helium, neon),
- Gases condensed at the cryopanel (e.g. nitrogen, oxygen, argon),
- Gases and vapors which have condensed on to the baffle and thermal radiation shield (e.g. water vapor).

The benefit of Leybold's regeneration process described above is that no additional purge gas is required during the regeneration of inert, unreactive gases. Nevertheless purge gas is available as an optional accessory for cryo pumps up to 10000 l/s

Our application support team is on hand to answer any safety questions you may have in relation to clientspecific process gases.

The accessories required for automatic regeneration, such as temperature sensors on both cold head stages, pressure gauge head, fore-vacuum valve and electrical controller are an integral part of the cryo pump in the iSmartLine range. Additional accessories can be supplied on request.

iBasicLine cryo pumps with no regulated regeneration system

In the case of cryo pumps from the iBasicLine (BL) range, regeneration takes place manually in two sub-steps:

- Switching off the refrigerator system and waiting until room temperature is reached. (The temperature can be read off by the customer from the built-in silicon diode).
- Re-cooling after a sufficiently low pressure is reached in the cryo pump.

Additional components such as temperature display unit, pressure gauge head and fore-vacuum valve are not part of the standard scope of delivery for iBasicLine cryo pumps, although they are available as accessories on request. Leybold will be pleased to advise you on the optimum component configuration for your application.

The cryo pumps from both the iBasicLine range as well as those from the iSmartLine range are available in suction capacity classes from 1500 l/s to 60000 l/s.

Multiple Operation of Refrigerator Cryo Pumps

The new powerful and energy efficient Leybold compressor units COOLPAK 5000i H open up the possibility of operating up to four refrigerator cryo pumps simultaneously.

Advantages for the User

- Significantly reduced investment and operating costs and low energy consumption - low cost of ownership (LoO9)
- Small footprint

Cold Heads

A refrigerator is a cooling machine which operates on the basis of a thermodynamic cycle (Carnot) to produce cryogenic temperatures ($T \leq 120$ K).

Refrigerators operating according to the Gifford/McMahon principle have succeeded over other methods of cooling cryo pumps and cryogenic applications. Mainly such coolers are produced and used by Leybold.

The cold heads consist essentially of three modules:

- Drive module
- Displacement unit
- Cold head stage(s)

Helium compressors from the COOLPAK i range are used to drive the cold heads from the COOLPOWER i range.

In addition to the standard products, Leybold also offers these cold heads, as well as cryo pumps, in custom designs in accordance with customer requirements.

Gifford/McMahon-Refrigerators

Advantages for the User

- No liquid helium and no liquid nitrogen are required
- Very simple to operate
- Easy process control and temperature control via a computer
- No space problems since cold head and compressor unit can be installed and operated apart
- Installation of the cold head basically in any orientation
- High reliability
- Long periods of operation without maintenance

Typical Applications

- Cooling of
 - cryopanel in cryo pumps thereby producing high or ultra-high vacuum
 - superconducting magnets; for instance in magnetic resonancetomography
 - samples for spectroscopic analysis in solid state and surface physics
 - high-temperature and low-temperature superconductors
 - infrared and gamma detectors
- Recondensation of liquids and cleaning of gases
- Calibration of sensors
- Space application (ion thruster, space simulation chamber)

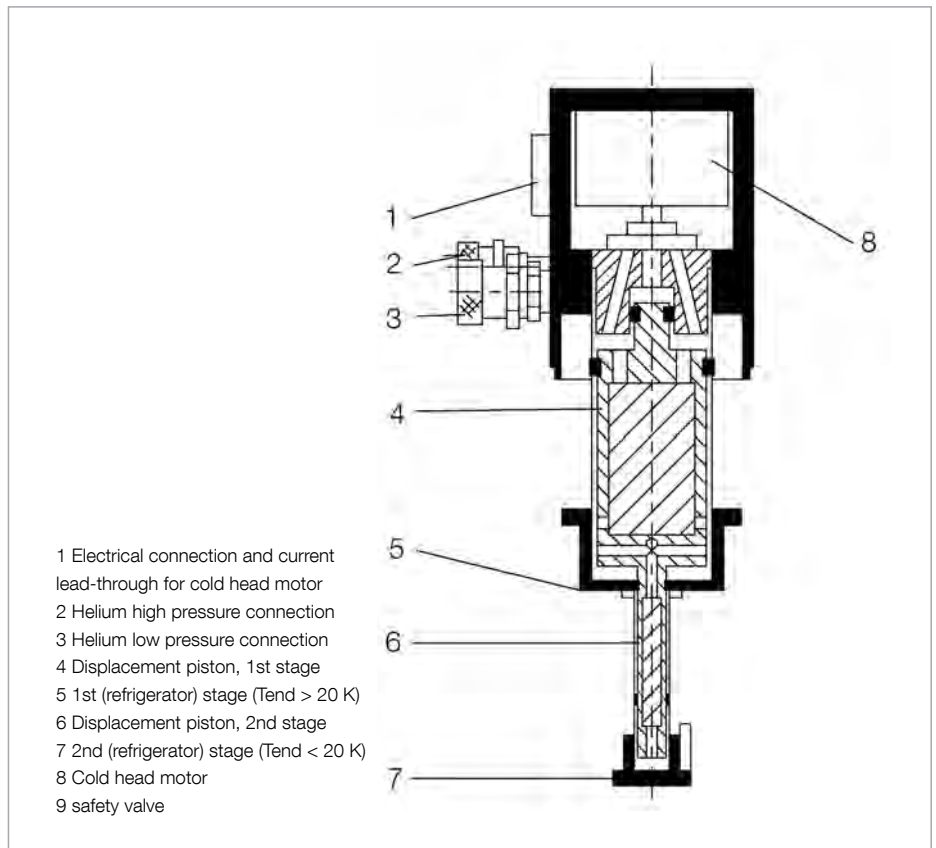

Dual-stage Gifford/McMahon cold head (schematic diagram)

Cold heads from the COOLPOWER i range

The standard range of single-stage and double-stage cold heads matches a wide range of applications.

Leybold is offering refrigerators with usable refrigerating powers from 20 W to 250 W at 80 K (single-stage).

In two-stage systems, the refrigeration capacities of the second stage range in between 5 W and 20 W at 20 K and/or 1.25W @ 4.2K.

Pneumatically driven cold heads

Advantages

- **Simple Design**
The pneumatic drive system for the displacer of these cold heads from Leybold consists of only two mechanically moving components: the rotating control valve and the stepper motor driving the control valve.
- **Easy and quick maintenance**
Owing to the simple design of the built-in cold heads, maintenance is easy. Maintenance can be performed in place without detaching the cold head from the vacuum chamber.

Mechanically driven cold heads

Advantages through low vibrations

With these cold heads, movement of the displacer unit is automatically controlled via a crank drive, which leads to low vibration levels.

Here, too, maintenance at the place of use may be carried out without impacting the surrounding infrastructure, in particular with no breaking of the chamber's vacuum by Leybold's service personnel.

Advantages through high reliability

Leybold cold heads are used in applications which place particularly high demands on reliability, such as magnetic resonance imaging in medical technology, the cooling of low and high temperature superconductors, and the cooling of detectors in telescopes for astronomy.

Refrigeration capacity diagrams (see next page of the catalogue)

On the following page of the catalogue you will find the refrigeration capacity diagrams for our single-stage and double-stage COOLPOWER i cold heads.

The interpretation of the diagrams for our double-stage cold heads is explained using the example of the refrigerator cold head COOLPOWER 5/100i (see diagram on next page). If applying heat loads of 100 W on the 1st stage and of 6 W on the 2nd stage, simultaneously, then the intersection point (●) 100 W / 6 W of the two lines gives the expected 1st stage and 2nd stage temperature of 80 K and of 20 K, respectively.

Without thermal load (left lower intersection point (o) 0 W / 0 W of this "load map"), ultimate temperatures of < 30 K and of < 10 K will be reached on the 1st stage and on the 2nd stage, respectively.

Refrigerating Capacity of Cryogenic Cold Heads



Typical refrigerating capacity of the single-stage cold heads COOLPOWER 25i - 50i - 140i - 250 MDi

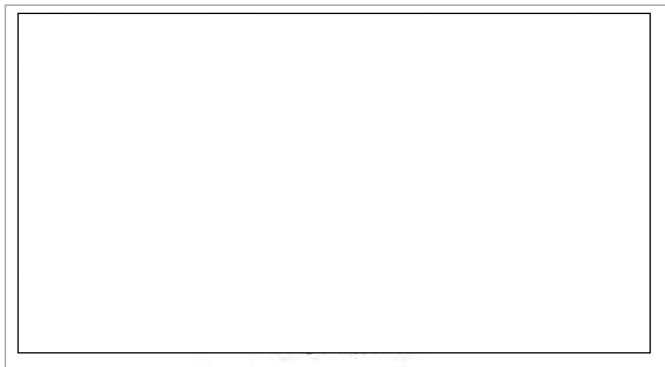

Complete new graph COOLPOWER 7/25i

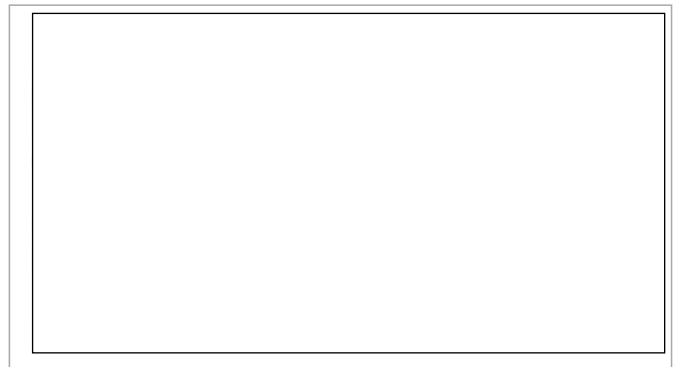

Typical refrigerating capacity of the cold head COOLPOWER 5/100

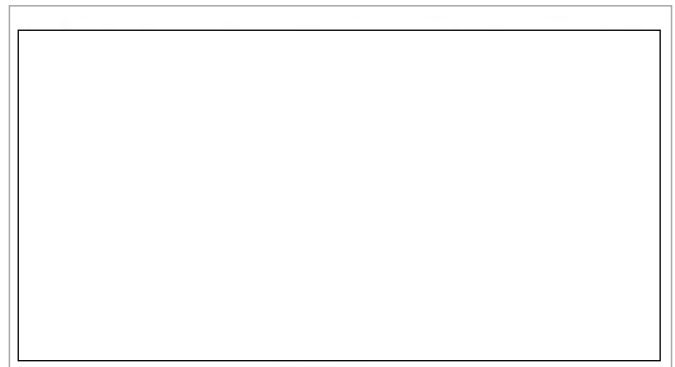

Typical refrigerating capacity of the cold head COOLPOWER 10 MD

The refrigerating capacities stated apply to vertical operation with the cold end at the and standard configuration with x m flexlines and ~ x bar static pressure.

Compressor Units

COOLPAK 2000i and COOLPAK 5000i H compressors are available for single and multiple operation of the cold heads from the COOLPOWER i line as well as for operation of cryo pumps from the COOLVAC i line.

The compressors are characterised by high reliability, low energy consumption and ease of maintenance. The maintenance interval is as long as 30,000 hours depending on the

application. The low level of noise and vibration is achieved through the exclusive use of scroll compressors and specially selected components.

The possibilities for single and multiple operation of refrigerator cryo pumps are given in the table below:

For the operation of

Compressor Unit	Cold Heads	Cryo Pumps
COOLPAK 2000i/2200	1 x COOLPOWER 50i 1 x COOLPOWER 7/25i	1 x COOLVAC 1500 / 2000 / 3000 iBL / iSL
COOLPAK 5000i HD	up to 4 x COOLPOWER 50i up to 4 x COOLPOWER 7/25i	4 up to x COOLVAC 1500 iBL / 2000 iBL / 3000 iBL and iSL 2 x COOLVAC 5000 iBL / 10000 iBL*)
COOLPAK 5000i H/6200 H	1 x COOLPOWER 140i T 1 x COOLPOWER 5/100i	up to 2 x COOLVAC 5000 iSL / 10000 iSL *) 1 x COOLVAC 5000 iBL / 10000 iBL
COOLPAK 5000i HMD/6200 HMD	1 x COOLPOWER 250 MDi 1 x COOLPOWER 10 MDi	1 x COOLVAC 30000 iBL LN ₂ 1 x COOLVAC 60000 iBL LN ₂

*) only after consulting with our technical support

Products Cryo Pumps

Cryo Pumps with fully Automatic Control, iSmartLine COOLVAC 1500 iCL and iSL-H



Advantages for the User

- Hydrocarbon-free high vacuum high pumping speed water and N₂
- High capacity for argon and hydrogen
- High crossover value
- Simple operation
- Trouble-free integration into complex systems
- Fully automatic regeneration through Cryo Compact Control ¹⁾
- Easy maintenance

Typical Applications

- Evaporators
- Sputtering systems
- Ion implanters
- Optical coating systems
- Metallization systems

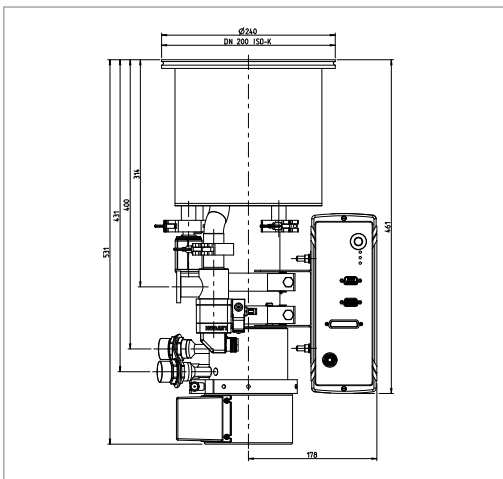

Dimensional drawing for the COOLVAC 1500 iSL (DN 200 ISO-K)

Technical Data

		COOLVAC 1500 iSL
High vacuum (HV) flange	DN	200 ISO-K / 200 CF / 6" ANSI
Fore vacuum flange ²⁾	DN	25 ISO-KF
Flange for connection a gauge head ³⁾	DN	16 ISO-KF
Flange for the electrical connection	DN	16 ISO-KF
Safety device with flange connection for gas exhaust line	DN	40 ISO-KF
4-pole current feedthrough for Si diode on a flange	DN	16 ISO-KF
Heaters	W	160
1 st stage	V AC	42
2 nd stage	W	90
	V AC	42
Temperature sensor		
1 st stage		Pt100
2 nd stage		Si diode
Pumping speed		
N ₂ at 2nd	I/s	4600 ± 10%
Ar / N ₂	I/s	1200 / 1500 ± 10%
H ₂	I/s	2500 ± 10%
Capacity		
Ar / N ₂	bar x l	1000 / 1000
H ₂ at 10 ⁻⁶ mbar	bar x l	15 ⁴⁾
Max. throughput		
Ar / N ₂	mbar x l/s (Torr x l/s)	12 (9) / 12 (9)
H ₂	mbar x l/s (Torr x l/s)	6 (4.5) ⁴⁾
Built-in cold head	COOLPOWER	7/25i
Crossover value	mbar x l (Torr x l)	210 (155)
Cooldown time to T ₂ = 20 K	min	60
Weight	kg (lbs)	25 (55.1)
Helium connections (self sealing fittings (male))	DN	1/2"

¹⁾ Accessories, necessary for automatic operations (i.e. electrical regeneration heaters, forevacuum valve DN 25 ISO-KF, and vacuum gauge DN 16 ISO-KF), are included with the scope of delivery and are connected to the integrated COOL.DRIVE i.

²⁾ Electropneumatic angle valve.

³⁾ Vacuum gauge head.

⁴⁾ The maximum throughput values given for hydrogen (H₂) are true for regenerated cryo pumps under short-term loads only. For continuous operations, both throughput and capacity values will be lower.

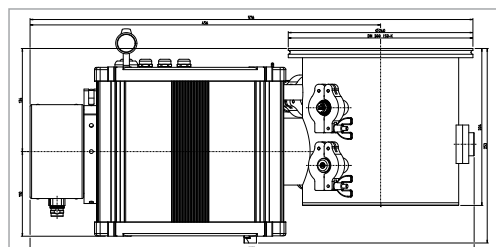

COOLVAC 1500 iSL-H
- DN 200 ISO K

Ordering Information
COOLVAC 1500 iSL

	Single Operation		Multiple Operation		Part No.
	Part No.	Part No.	High Voltage	Low Voltage	
COOLVAC 1500 iCL DN 200 CF DN 6" ANSI DN 200 ISO-K	844202V0002 844202V0004 844201V0006		844202V0002 (up to 4) 844201V0004 (up to 4) 844201V0006 (up to 4)		Should we delete this column?
Compressors, flexlines and cables					
Compressor COOLPOWER 2000i	840000V1211	840000V1211	-	-	-
CP 5000i H	840000V5411	840000V5411/5211	840000V5422 (2) or 5444 (up to 4)	840000V5222	-
Power supply cable for compressor	-		see Ordering Information of the compressor units		
Set of flexlines FL 4.5 (1/2", 1/2") or FL 9.0 (1/2", 1/2") or FL 18.0 HP (1/2") + FL 18.0 LP (1/2")	892 87 892 88 840203 + 840204		892 87 (up to 4) 892 88 (2x) 840203 (up to 4) + 840204 (up to 4)		892 87 (3x) 892 88 (3x) 840203 (3x) + 840204 (3x)
Gas manifold (1 piece each) GD 2 GD 4	- -		840 253 (up to 4) -		- 840 254 (2x)
Compressor unit control cable ¹⁾ COOLPAK control cable, 5 m (16.4 ft) or COOLPAK control cable, 10 m (32.81 ft) or COOLPAK control cable, 20 m (65.62 ft) COOLPAK adapter for multi control	844231V4005 844231V4010 844231V4020 -		844231V4005 (2x) 844231V4010 (2x) 844231V4020 (2x) 844231V5003		844231V4005 (3x) 844231V4010 (3x) 844231V4020 (3x) 844231V5003
Optional electronics, cables and equipment					
CRYOVISION control and display unit					
CRYOVISION control cables CRYOVISION control cable, 5 m (16.4 ft) or CRYOVISION control cable, 10 m (32.81 ft) or CRYOVISION control cable, 20 m (65.62 ft)	844231V2005 844231V2010 844231V2020		844231V2005 844231V2010 844231V2020		844231V2005 844231V2010 844231V2020
Optional interface module					
COOLVAC ProfiBus module ProfiBus – RS232 Converter for COOL.DRIVE and CRYOVISION either COOLVAC ProfiBus module connected to COOL.DRIVE control and monitoring unit of each cryo pump (in this case CRYOVISION and network control not to apply)	844000V1		844000V1(2x)		844000V1(3x)
or COOLVAC ProfiBus module connected to CRYOVISION ²⁾	844000V1		844000V1		844000V1

The arrangement of the components is shown in the chapter "Accessories" under the heading "COOLVAC iSmartLine, System Components".

¹⁾ The length of the control cable should match to the length of the flexlines.

²⁾ At multiple operation with reduced communication speed to single cryo pumps.

COOLVAC 2000 iSL

COOLVAC 3000 iSL



Advantages for the User

- Hydrocarbon-free high vacuum
- High capacity for argon and hydrogen
- High crossover value
- Simple operation
- Trouble-free integration into complex systems
- Fully automatic regeneration through Cryo Compact Control ¹⁾
- Easy on-site servicing without pump disassembling and reconditioning of the vacuum system possible

Advantages for the User

- Hydrocarbon-free high vacuum
- High capacity for argon and hydrogen
- High crossover value
- Simple operation
- Trouble-free integration into complex systems
- Fully automatic regeneration through integrated COOL.DRIVE controller ¹⁾
- Easy on-site servicing without pump disassembling and reconditioning of the vacuum system possible

Typical Applications

- Evaporators
- Sputtering systems
- Ion implanters
- Optical coating systems
- Metallization systems

Typical Applications

- Evaporators
- Sputtering systems
- Ion implanters
- Optical coating systems
- Metallization systems

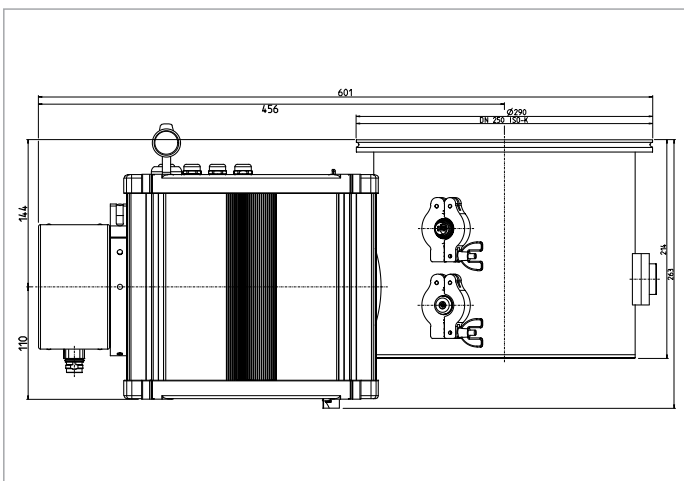

Dimensional drawing for the COOLVAC 2000 iCL (DN 250 ISO-K)

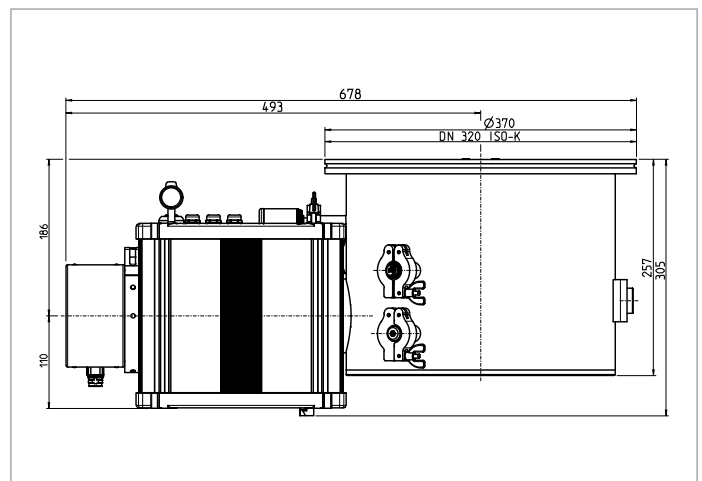

Dimensional drawing for the COOLVAC 3000 iCL (DN 320 ISO-K)

Technical Data	COOLVAC		
		2000 iSL	3000 iSL
		250 ISO-K / 250 CF / 8" ANSI	320 ISO-K / 10" ANSI
High vacuum (HV) flange	DN	250 ISO-K / 250 CF / 8" ANSI	320 ISO-K / 10" ANSI
Fore vacuum flange ²⁾	DN	25 ISO-KF	
Flange for connection a gauge head ³⁾	DN	16 ISO-KF	
Flange for the electrical connection	DN	16 CF	
Safety device with flange connection for gas exhaust line	DN	40 ISO-KF	
4-pole current feedthrough for Si diode on a flange	DN	16 ISO-KF	
Heaters			
1st stage	W	160	
	V AC	42	
2nd stage	W	90	
	V AC	42	
Temperature sensor			
1st stage		Pt100	
2nd stage		Si diode	
Pumping speed			
N ₂ at 2nd	I/s	7000	10500
Ar / N ₂	I/s	1600 / 2100	2500 / 3000
H ₂	I/s	3200	6000
Capacity			
Ar / N ₂	bar x l	1600 / 1600	2500 / 2500
H ₂ at 10 ⁻⁶ mbar	bar x l	15 ⁴⁾	28 ⁴⁾
Max. throughput			
Ar / N ₂	mbar x l/s (Torr x l/s)	12 (9) / 12 (9)	15 (11.2) / 15 (11.2)
H ₂	mbar x l/s (Torr x l/s)	6 (4.5) ⁴⁾	10 (7.5) ⁴⁾
Built-in cold head	COOL-POWER	7/25i	
Crossover value	mbar x l (Torr x l)	250 (187)	500 (375)
Cooldown time to T ₂ = 20 K	min	70	120
Weight	kg (lbs)	29 (64)	35 (101.4)
Helium connections (self sealing fittings (male))	DN	1/2"	

¹⁾ Accessories, necessary for automatic operations (i.e. electrical regeneration heaters, forevacuum valve DN 25 ISO-KF, and vacuum gauge DN 16 ISO-KF), are included with the scope of delivery and are connected to the integrated COOLDRIVE i.

²⁾ Electropneumatic angle valve.

³⁾ Vacuum gauge head included.

⁴⁾ The maximum throughput values given for hydrogen (H₂) are true for regenerated cryo pumps under short-term loads only. For continuous operations, both throughput and capacity values will be lower.

Ordering Information

COOLVAC 2000 iSL

	Single Operation		Operation		Multiple Operation	
	Part No.		High Voltage	Low Voltage	High Voltage	Low Voltage
COOLVAC 2000 iSL DN 250 CF DN 8" ANSI DN 250 ISO-K	Part No.		Part No.		Part No.	
	844252V0002		844252V0002 (up to 4)		844251V0002 (3x)	
	844252V0004		844252V0004 (up to 4)		844251V0004 (3x)	
	844252V0006		844252V0006 (up to 4)		844251V0006 (3x)	
Compressors, flexlines and cables						
Compressor CP 2000i	840000V1211	840000V1211	-	-	-	-
CP 5000i	840000V5411	840000V5411/ 840000V5211	840000V5422 (2) / 840000V5444 (up to 4)	840000V5222	840000V6001	-
Power supply cable for compressor	-		see Ordering Information of the compressor units			
Set of flexlines FL 4.5 (1/2", 1/2") or FL 9.0 (1/2", 1/2") or FL 18.0 HP (1/2") + FL 18.0 LP (1/2")	892 87 892 88 840203 + 840204		892 87 (up to 4) 892 88 (2x) 840203 (up to 4) + 840204 (up to 4)		892 87 (3x) 892 88 (3x) 840203 (3x) + 840204 (3 x)	
Gas manifold (1 piece each) GD 2 GD 4	- -		840 253 (up to 4) -		- 840 254 (2x)	
Compressor unit control cable ¹⁾ COOLPAK control cable, 5 m or COOLPAK control cable, 10 m or COOLPAK control cable, 20 m COOLPAK adapter for multi control	844231V4005 844231V4010 844231V4020 -		844231V4005 (2x) 844231V4010 (2x) 844231V4020 (2x) 844231V5003		844231V4005 (3x) 844231V4010 (3x) 844231V4020 (3x) 844231V5003	
Optional electronics, cables and equipment						
CRYOVISION control and display unit	844231V0002		844231V0002		844231V0002	
CRYOVISION control cables CRYOVISION control cable, 5 m or CRYOVISION control cable, 10 m or CRYOVISION control cable, 20 m	844231V2005 844231V2010 844231V2020		844231V2005 844231V2010 844231V2020		844231V2005 844231V2010 844231V2020	
Optional interface module						
COOLVAC ProfiBus module ProfiBus – RS232 Converter for COOL.DRIVE and CRYO- VISION either COOLVAC ProfiBus module connected to COOL.DRIVE control and monitoring unit of each cryo pump (in this case CRYOVISION and network control not to apply)	844000V1		844000V1(2x)		844000V1(3x)	
or COOLVAC ProfiBus module connected to CRYOVISION ²⁾	844000V1		844000V1		844000V1	

High Vacuum Pumps

The arrangement of the components is shown in the chapter "Accessories" under the heading "COOLVAC iSmartLine, System Components".

¹⁾ The length of the control cable should match to the length of the flexlines.
²⁾ At multiple operation with reduced communication speed to single cryo pumps.

Single Operation

Operation

High Voltage

Low Voltage

	Part No.		Part No.	
COOLVAC 3000 iCL DN 10" ANSI DN 320 ISO-K	844322V0004 844322V0006		844322V0004 (up to 4) 844322V0006 (up to 4)	
Compressors, flexlines and cables				
Compressor CP 2000i	840000V1211	840000V1211	-	-
CP 5000i	840000V5411	840000V5411/ 840000V5211	840000V5422 (2) / 840000V5444 (up to 4)	840000V5222
Power supply cable for compressor	-		see Ordering Information of the compressor units	
Set of flexlines FL 4.5 (1/2", 1/2") or FL 9.0 (1/2", 1/2") or FL 18.0 HP (1/2") + FL 18.0 LP (1/2")	892 87 892 88 840203 + 840204		892 87 (up to 4) 892 88 (2x) 840203 (up to 4) + 840204 (up to 4)	
Gas manifold (1 piece each) GD 2	-		840 253 (up to 4)	
Compressor unit control cable ¹⁾ COOLPAK control cable, 5 m or COOLPAK control cable, 10 m or COOLPAK control cable, 20 m COOLPAK adapter for multi control	844231V4005 844231V4010 844231V4020 -		844231V4005 (2x) 844231V4010 (2x) 844231V4020 (2x) 844231V5003	
Optional electronics, cables and equipment				
CRYOVISION control and display unit	844231V0002		844231V0002	
CRYOVISION control cables CRYOVISION control cable, 5 m (16.4 ft) or CRYOVISION control cable, 10 m (32.81 ft) or CRYOVISION control cable, 20 m (65.62 ft)	844231V2005 844231V2010 844231V2020		844231V2005 844231V2010 844231V2020	
Network control cable for the link between the pumps CRYOVISION / Network control cable, 5 m (16.4 ft) or CRYOVISION / Network control cable, 10 m (32.81 ft) or CRYOVISION / Network control cable, 20 m (65.62 ft)	- - -		844231V2005 844231V2010 844231V2020	
Optional interface module				
COOLVAC ProfiBus module ProfiBus – RS232 Converter for COOL.DRIVE and CRYOVISION either COOLVAC ProfiBus module connected to COOL.DRIVE control and monitoring unit of each cryo pump (in this case CRYOVISION and network control not to apply)	844000V1		844000V1(2x)	
or COOLVAC ProfiBus module connected to CRYOVISION ²⁾	844000V1		844000V1	

The arrangement of the components is shown in the chapter "Accessories" under the heading "COOLVAC iSmartLine, System Components".

¹⁾ The length of the control cable should match to the length of the flexlines.

²⁾ At multiple operation with reduced communication speed to single cryo pumps.

COOLVAC 5000 iCL

COOLVAC 10000 iCL



Advantages for the User

- Hydrocarbon-free high vacuum
- High capacity for argon and hydrogen
- High crossover value
- Simple operation
- Trouble-free integration into complex systems
- Fully automatic regeneration through Cryo Compact Control ¹⁾
- Easy on-site servicing without pump disassembling and reconditioning of the vacuum system possible

Advantages for the User

- Hydrocarbon-free high vacuum
- High capacity for argon and hydrogen
- High crossover value
- Simple operation
- Trouble-free integration into complex systems
- Fully automatic regeneration through integrated COOL.DRIVE controller ¹⁾
- Easy on-site servicing without pump disassembling and reconditioning of the vacuum system possible

Typical Applications

- Evaporators
- Electron beam welding systems
- Ion implanters
- Optical coating systems
- Metallization systems

Typical Applications

- Evaporators
- Electron beam welding systems
- Ion implanters
- Optical coating systems
- Metallization systems

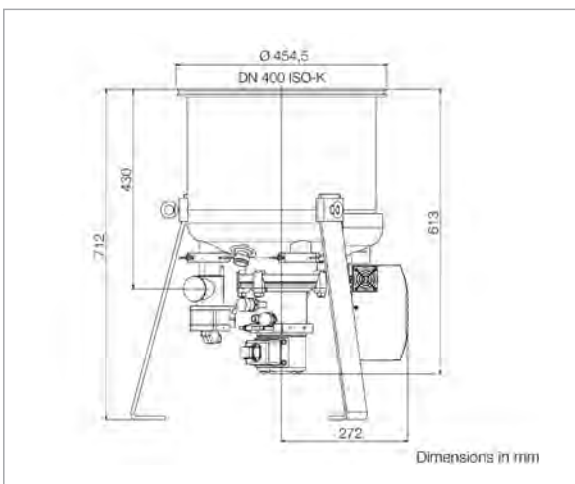

Dimensional drawing for the COOLVAC 5000 iCL

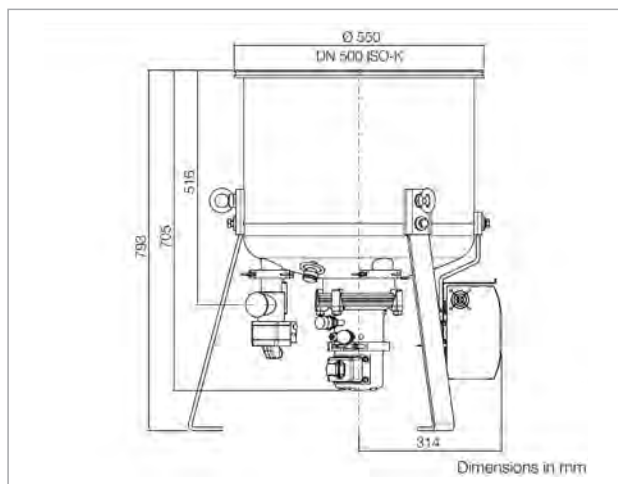

Dimensional drawing for the COOLVAC 10000 iCL

Technical Data

COOLVAC

5000 iCL

10000 iCL

		5000 iCL	10000 iCL
High vacuum (HV) flange	DN	400 ISO-K	500 ISO-K / 500 – 20" ANSI
Fore vacuum flange ²⁾	DN	40 ISO-KF	
Flange for connection a gauge head ³⁾	DN	16 ISO-KF	
Flange for the electrical connection	DN	40 ISO-KF	
Pressure-relief device with flange connection for gas exhaust line	DN	40 ISO-KF	
4-way current feedthrough for Si diode on a flange	DN	16 ISO-KF	
Heaters			
1st stage	W V AC	160 42	
2nd stage	W V AC	90 42	
Temperature sensor			
1st stage		Pt100	
2nd stage		Si diode	
Pumping speed			
H ₂ O	l/s	18000	30000
Ar / N ₂	l/s	4000 / 5200	8400 / 10000
H ₂	l/s	6200	10000
Capacity			
Ar / N ₂	bar x l	3000 / 3000	5500 / 5500
H ₂ at 10 ⁻⁶ mbar	bar x l	32 ⁴⁾	45 ⁴⁾
Max. throughput			
Ar / N ₂	mbar x l/s (Torr x l/s)	10 (7.5) / 10 (7.5)	
H ₂	mbar x l/s (Torr x l/s)	7 (5.3) ⁴⁾	
Built-in cold head	COOLPOWER	5/100	
Crossover value	mbar x l (Torr x l)	700 (525)	800 (600)
Cooldown time to T ₂ = 20 K	min	100	150
Weight	kg (lbs)	53 (116.9)	70 (154.3)
Helium connections (Self-sealing couplings: outside thread, type 5400-S2-8)	DN	1/2"	

¹⁾ Accessories, necessary for automatic operations (i.e. electrical regeneration heaters, forevacuum valve DN 25 ISO-KF, and vacuum gauge DN 16 ISO-KF), are included with the scope of delivery and are connected to the integrated COOL.DRIVE.

²⁾ Electropneumatic angle valve included.

³⁾ Vacuum gauge head included.

⁴⁾ The maximum throughput values given for hydrogen (H₂) are true for regenerated cryo pumps under short-term loads only. For continuous operations, both throughput and capacity values will be lower.

Ordering Information

COOLVAC 5000 iCL **COOLVAC 10000 iCL**
Europe **USA/Japan** **High Voltage** **Low Voltage**

	Part No.		Part No.	
COOLVAC 5000 iCL, DN 400 ISO-K	844251V0006		-	
COOLVAC 10000 iCL, DN 500 20" ANSI	-		844511V0004	
COOLVAC 10000 iCL, DN 500 ISO-K	-		844511V0006	
Compressors, flexlines and cables				
Compressor				
CP 6000 H	840000V6001	-	840000V6001	-
CP 6200 H	-	840000V6201	-	840000V6201
Power supply cable for compressor	see Ordering Information of the compressor units			
Set of flexlines				
FL 4.5 (1/2", 1/2")	892 87		892 87 (2x)	
or FL 9.0 (1/2", 1/2")	892 88		892 88 (2x)	
or FL 18.0 HP (1/2") + FL 18.0 LP (1/2")	840203 + 840204		840203 (2x) + 840204 (2 x)	
Gas manifold (1 piece each)				
GD 2	-		840 253 (2x)	
Compressor unit control cable ¹⁾				
COOLPAK control cable, 5 m (16.4 ft)	844231V4005		844231V4005	
or COOLPAK control cable, 10 m (32.81 ft)	844231V4010		844231V4010	
or COOLPAK control cable, 20 m (65.62 ft)	844231V4020		844231V4020	
Optional electronics, cables and equipment				
CRYOVISION control and display unit	844231V0002		844231V0002	
CRYOVISION control cables				
CRYOVISION control cable, 5 m (16.4 ft)	844231V2005		844231V2005	
or CRYOVISION control cable, 10 m (32.81 ft)	844231V2010		844231V2010	
or CRYOVISION control cable, 20 m (65.62 ft)	844231V2020		844231V2020	
Optional interface module				
COOLVAC ProfiBus module				
ProfiBus – RS232 Converter for COOL.DRIVE and CRYOVISION	844000V1		844000V1	

The arrangement of the components is shown in the chapter "Accessories" under the heading "iCOOLVAC iClassicLine, System Components".

¹⁾ The length of the control cable should match to the length of the flexlines.

COOLVAC 18000 iCL



COOLVAC 18000 iCL with flange DN 630 ISO-F

Advantages for the User

- Hydrocarbon-free high vacuum
- High pumping speed for water vapor and nitrogen
- Fast, safe and efficient regeneration with the electric regeneration system ¹⁾
- Simple operation

Typical Applications

- Space simulation chambers
- Evaporators
- Electron beam welding systems
- Optical coating systems
- Metallization systems

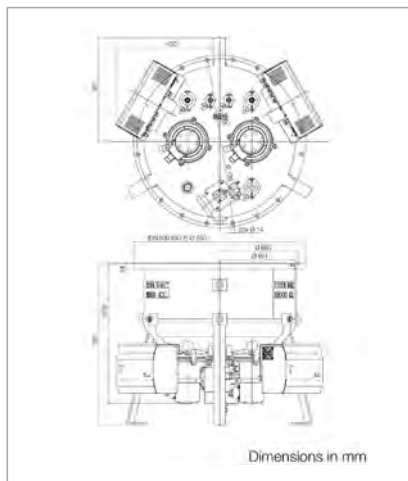

Dimensional drawing for the COOLVAC 18000 iCL

COOLVAC 30000 iCL



COOLVAC 30000 iCL with special flange

Advantages for the User

- Hydrocarbon-free high vacuum
- High pumping speed for water vapor and nitrogen
- Fast, safe and efficient regeneration with the electric regeneration system ¹⁾
- Simple operation

Typical Applications

- Space simulation chambers
- Evaporators
- Electron beam welding systems
- Optical coating systems
- Metallization systems

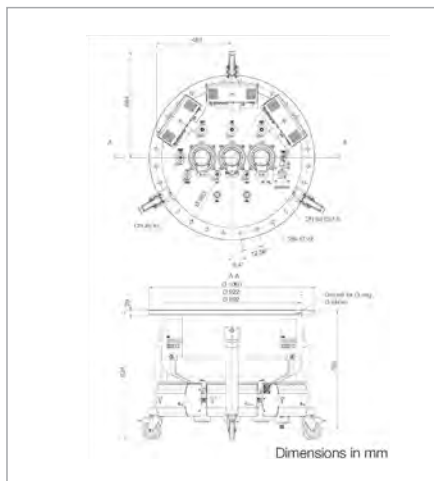

Dimensional drawing for the COOLVAC 30000 iCL

COOLVAC 60000 iCL



COOLVAC 60000 iCL with flange DN 1250 ISO-F

Advantages for the User

- Hydrocarbon-free high vacuum
- High pumping speed for water vapor and nitrogen
- Fast, safe and efficient regeneration with the electric regeneration system ¹⁾
- Simple operation

Typical Applications

- Space simulation chambers
- Evaporators
- Electron beam welding systems
- Optical coating systems
- Metallization systems

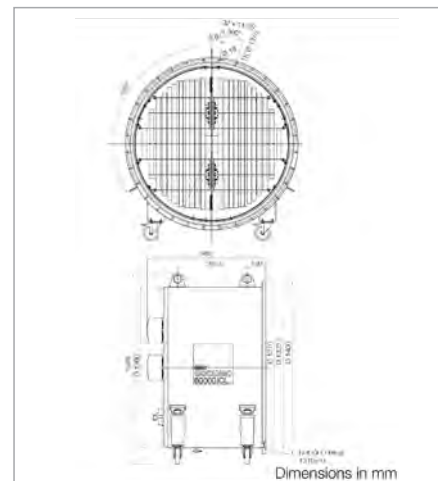

Dimensional drawing for the COOLVAC 60000 iCL

Technical Data		COOLVAC 18000 iCL	COOLVAC 30000 iCL	COOLVAC 60000 iCL
High vacuum flange	DN	630 ISO-F	35"ANSI	1250 ISO-F
Fore vacuum flange ²⁾	DN	63 ISO-K	63 ISO-K	63 ISO-K
Flange with current feedthrough for silicon diode	DN	25 ISO-KF (2x)	16 ISO-KF (2x)	16 ISO-KF (2x)
Flange for other purposes	DN	40 ISO-KF	-	-
Flange with 11-way feedthrough with additional Pt 100 on flange	DN	-	40 ISO-KF	40 ISO-KF
Pressure-relief device with flange connection for gas exhaust line		40 ISO-KF	40 ISO-KF	40 ISO-KF
Pumping speed				
H ₂ O	l/s	46000	93000	180000
Ar / N ₂	l/s	13500 / 18000	25000 / 30000	47000 / 57000
H ₂	l/s	14000	30000	60000
Capacity				
Ar / N ₂	bar x l	6000	6000	9000
H ₂ at 10 ⁻⁶ mbar	bar x l	65 ³⁾	100 ³⁾	150 ³⁾
Built-in cold head	COOLPOWER	5/100 (2x)	5/100 (2x) and 140T (1x)	5/100 (2x) and 140T (2x)
Max. throughput				
Ar / N ₂	mbar x l/s (Torr x l/s)	14 (10.5)	14 (10.5)	25 (18.75)
H ₂	mbar x l/s (Torr x l/s)	7 (5.25) ³⁾	7 (5.25) ³⁾	12 (9) ³⁾
Crossover value at 20 K	mbar x l (Torr x l)	800 (600)	1200 (900)	1000 (750)
Cool down time to 20 K	min	180	260	330
Overall height	mm	see drawing	see drawing	see drawing
Weight	kg (lbs)	131 (289)	262 (577.6)	503 (1109)
Silicon diode for temperature measurements at the second stage of the cold head		built-in (2x)	built-in (2x)	built-in (2x)
Regeneration heaters at the first stage of the cold head		built-in (2x)	built-in (2x)	built-in (2x)
second stage of the cold head		built-in (2x)	built-in (2x)	built-in (2x)

¹⁾ Accessories, necessary for automatic operations (i.e. electrical regeneration heaters, forevacuum valve DN 25 ISO-KF, and vacuum gauge DN 16 ISO-KF), are included with the scope of delivery and are connected to the integrated COOL.DRIVE.

²⁾ Electropneumatic angle valve included.

³⁾ The maximum throughput values given for hydrogen (H₂) are true for regenerated cryo pumps under short-term loads only. For continuous operations, both throughput and capacity values will be lower.

Ordering information

COOLVAC 18000 iCL
COOLVAC 30000 iCL
COOLVAC 60000 iCL
High Voltage Low Voltage
High Voltage Low Voltage
High Voltage Low Voltage

	Part No.	Part No.	Part No.
COOLVAC 18 000 iCL, DN 630 ISO-F	844631V0006	-	-
COOLVAC 30 000 iCL, 35" ANSI	-	844891V9005	-
COOLVAC 60 000 iCL, DN 1250 ISO-F	-	-	844896V9005

Compressors, flexlines and cables

Compressor CP 6000 H	840000V6001	-	840000V6001	-	840000V6001	-
CP 6200 H	(2x)	840000V6201	(3x)	840000V6201	(4x)	840000V6201
	-	(2x)	-	(3x)	-	(4x)
Power supply cable for compressor	see Ordering Information of the compressor units					
Set of flexlines FL 4.5 (1/2", 1/2") or FL 9.0 (1/2", 1/2") or FL 18.0 HP (1/2") + FL 18.0 LP (1/2")	892 87 (2x) 892 88 (2x) 840203 (2x) + 840204 (2x)		892 87 (3x) 892 88 (3x) 840203 (3x) + 840204 (3x)		892 87 (4x) 892 88 (4x) 840203 (4x) + 840204 (4x)	
Compressor unit control cable ¹⁾ COOLPAK control cable, 5 m (16.4 ft) or COOLPAK control cable, 10 m (32.81 ft) 844231V4010 (2x) 844231V4010 (3x) 844231V4010 (4x) or COOLPAK control cable, 20 m (65.62 ft)	844231V4005 (2x) 844231V4010 (2x) 844231V4020 (2x)		844231V4005 (3x) 844231V4010 (3x) 844231V4020 (3x)		844231V4005 (4x) 844231V4010 (4x) 844231V4020 (4x)	

Optional electronics, cables and equipment

CRYOVISION control and display unit	844231V0002
CRYOVISION network / control cable CRYOVISION / Network control cable, 5 m (16.4 ft) or CRYOVISION / Network control cable, 10 m (32.81 ft) or CRYOVISION / Network control cable, 20 m (65.62 ft)	844231V2005 844231V2010 844231V2020

Optional interface module

COOLVAC ProfiBus module ProfiBus – RS232 Converter for COOL.DRIVE and CRYOVISION	844000V1
---	-----------------

The arrangement of the components is shown in the chapter "Accessories" under the heading "iCOOLVAC iClassicLine, System Components".

¹⁾ The length of the control cable should match to the length of the flexlines.

Cryo Pumps for Manual Operation, BasicLine

The COOLVAC cryo pumps of the BasicLine version are identical to the COOLVAC cryo pumps of the iClassicLine version concerning the technical data for pumping speed, capacity, cooldown time, built-in cold heads, maximum throughput, built-in temperature sensors for the second stage (Si diode) and the corresponding current feedthroughs.

The standard BasicLine models do not include the following components:

- Electrical regeneration heaters
- Temperature sensors for the first stages of the cold head(s)
- Vacuum gauge head
- Fore vacuum valve
- Temperature readout / display unit for the silicon diode(s)

We are glad to advise you of our assortment of accessories for our COOLVAC BasicLine range of cryo pumps.

All cryo pumps of the *iClassicLine* series (iCL) described above can be delivered as *BasicLine* types, too. Please consult with our technical support.

E.g. for the following part numbers:

	Part No.
COOLVAC 10000 BL-V, DN 500 20" ANSI	844511V1004
COOLVAC 10000 BL-V, DN 500 ISO-K	844511V1006

Cryo Pumps with Liquid Nitrogen Cooling of Radiation Shield and Baffle of Cryo Pump

COOLVAC 30000 BL LN₂ and COOLVAC 60000 BL LN₂



COOLVAC 30000 BL LN₂



COOLVAC 60000 BL LN₂ with flange DN 1250 ISO-F

Advantages for the User

- Hydrocarbon-free high vacuum
- High pumping speed for water vapor and nitrogen
- Operating with only one compressor unit through liquid nitrogen (LN₂) cooling of radiation shield and baffle
- Controlling of radiation shield and baffle temperatures by additional temperature sensor

Typical Applications

- Space simulation chambers
- Vacuum furnaces

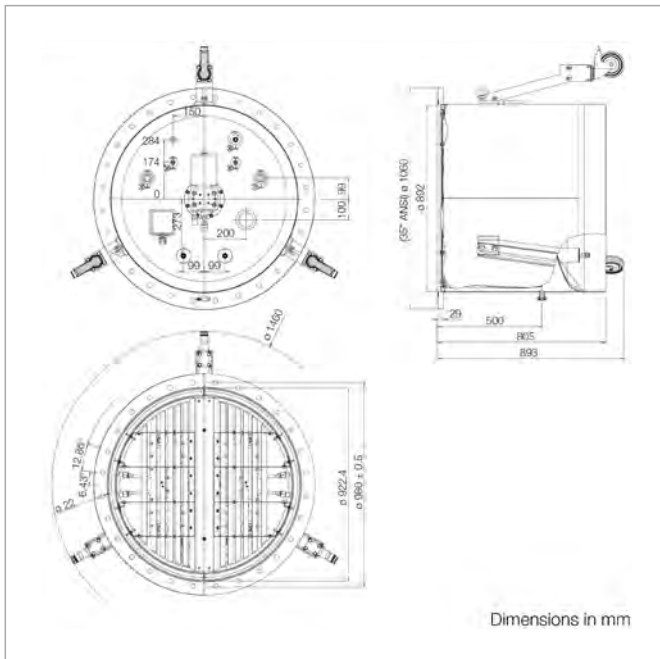

Dimensional drawing of COOLVAC 30000 BL LN₂

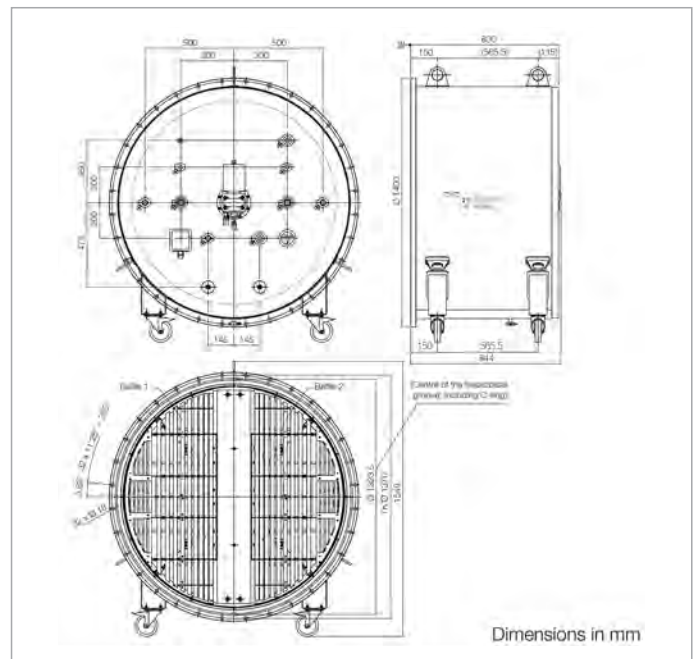

Dimensional drawing of COOLVAC 60000 BL LN₂

High vacuum flange	DN	35"ANSI	1250 ISO-F
Fore vacuum flange	DN	63 ISO-K	63 ISO-K
Flange with 4-pole current feedthrough for silicon diode*	DN	16 ISO-KF (2x)	16 ISO-KF (2x)
Flange with 6-pole current feedthrough for 3 Pt 100 (radiation shield and baffle halves)	DN	40 ISO-KF	40 ISO-KF
Pressure-relief device with flange connection for gas exhaust line	DN	40 ISO-KF	40 ISO-KF
Flange with abnormal temperature protection for the regeneration heaters of the built-in cold head	DN	40 ISO-KF	40 ISO-KF
Pumping speed			
H ₂ O	l/s	93000	180000
Ar / N ₂	l/s	25000 / 30000	47000 / 57000
H ₂	l/s	30000	60000
Capacity			
Ar / N ₂	bar x l	6500	9000
H ₂ at 10 ⁻⁶ mbar	bar x l	100 ¹⁾	150 ¹⁾
Built-in cold head	COOLPOWER	10 MD	10 MD
Max. throughput	mbar x l/s (Torr x l/s)	> 15 (11.25) ¹⁾	> 30 (22.5) ¹⁾
Ar / N ₂			
Crossover value at 20 K	mbar x l (Torr x l)	2000 (1500)	3000 (2250)
LN ₂ consumption, ca.	l/h	7	10
LN ₂ connections		SS-8-VCR (1/2")	SS-8-VCR (1/2")
Cool down time to 20 K, approx.	h	5	6
Overall height	mm	see drawing	see drawing
Weight, approx.	kg (lbs)	300 (661)	400 (882)
Silicon diode for temperature measurements at the second stage of the cold head		built-in	built-in
Regeneration heaters at the			
first stage of the cold head		built-in	built-in
second stage of the cold head		built-in	built-in

* temperature sensor at the second stage of the cold head.

¹⁾ The maximum throughput values given for hydrogen (H₂) are true for regenerated cryo pumps under short-term loads only. For continuous operations, both throughput and capacity values will be lower.

Ordering Information

COOLVAC 30000 BL LN₂
High Voltage Low Voltage

COOLVAC 60000 BL LN₂
High Voltage Low Voltage

	Part No.	Part No.
COOLVAC 30 000 BL LN ₂ , 35" ANSI	844890V9501	-
COOLVAC 60 000 BL LN ₂ , DN 1250 ISO-F	-	844895V9503

Compressors, flexlines and cables

Compressor	High Voltage	Low Voltage	High Voltage	Low Voltage
CP 6000 HMD, 400 V / 50 Hz / 460 V / 60 Hz / 3-ph.	840000V6002	-	840000V6002	-
CP 6200 HMD, 200 V / 50 Hz / 200 – 230 V / 60 Hz / 3-ph.	-	840000V6202	-	840000V6202

Power supply cable for compressor **see Ordering Information of the compressor units**

Flexible pressure line (for operating mechanically driven cold heads)	
9 m (29.53 ft), FL9 HP – DN20 (8f/8f) + FL9 LP – DN32 (8f/8f)	840217 + 840218V0032
20 m (65.62 ft), FL20 HP – DN20 (8f/8f) + FL20 LP – DN32 (8f/8f)	840230V2020 + 840231V2032

Cable cold head motor compressor unit ¹⁾	
9 m (29.53 ft),	842 110
20 m (65.62 ft)	842 112

Optional equipment and cables

Low temperature measuring instrument MODEL 211S	844 110
HV cable, 4-way, with plug to the MODEL 211S	
10 m (32.81 ft)	844 113
20 m (65.62 ft)	844113V20

Additional accessories (selection)

Forevacuum valves ²⁾	
Right-Angle DN 63 ISO-K, electropneumatically operated, with pilot valve 24 V DC, Aluminum body	10800V01
Right-Angle DN 63 ISO-K, electropneumatically operated, with pilot valve 24 V DC, stainless steel body	10810V01
Pressure sensor	
THERMOVAC Transmitter TTR 91 N, DN 16 ISO-KF (without switching threshold)	230035V02
THERMOVAC Transmitter TTR 91 N, DN 16 ISO-KF, (with switching threshold, 2SP)	230040V02
Connection cable to TTR 91 N, FCC 68 on both ends, 8-way shielded ³⁾	Type A
10 m (32.81 ft)	230 012
20 m (65.62 ft)	124 28
30 m (98.43 ft)	124 29

¹⁾ The length of the control cable should match to the length of the flexlines.

²⁾ See catalog "Valves" for additional right-angle valves.

³⁾ The length of the control cable should match to the length of the flexlines.

Products Cryo Pumps

Cold Heads, Pneumatically Driven
Single-Stage Cold Heads
COOLPOWER 50 and 140 T



Single-stage cold head's COOLPOWER 50 (left) and 140 T (right)

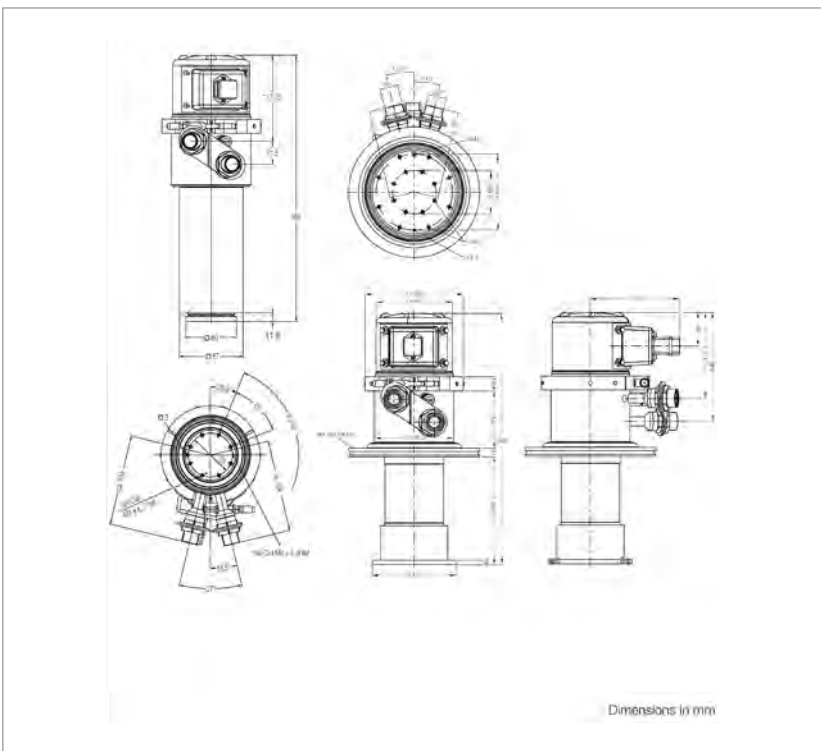

Dimensional drawing for the COOLPOWER 50 (left) and COOLPOWER 140 T (right)

Advantages for the User

- For installation mostly in any orientation
- High refrigerating capacity
- No liquid refrigerants are required
- Very simple to operate
- Short cooldown timer

Typical Applications

- Cooling of samples, sensors and detectors
 - e. g. cooling of detectors in astronomy
- Cooling of HTS superconductors
- Cooling in magnetic equipment
- Cooling of surfaces for pumping of gases
- Cryogenic process gas cleaning
- Condensation, resublimation and freezing of gases

Technical Data

COOLPOWER 50

COOLPOWER 140 T

Refrigeration capacity at 50/60 Hz ¹⁾ at 80 K, approx. at 20 K, approx.	W	50	140
	W	-	20
Lowest attainable temperature ¹⁾	K	≤ 26	≤ 15
Cooldown time down to 20 K, approx. to 80 K, approx.	min	-	55
	min	20	-
Permissible ambient temperature	°C (°F)	+10 to +40 (+50 to +104)	+10 to +40 (+50 to +104)
He filling pressure at room temperature	barg	16	16
He connections Self-sealing screwed connections High pressure connection Low pressure connection			
		1/2" ²⁾	1/2" ²⁾
		1/2" ²⁾	1/2" ²⁾
Weight	kg (lbs)	8 (17.7)	12 (26.5)

Ordering Information

COOLPOWER 50

COOLPOWER 140 T

		Part No.		Part No.		
Cold head with DN 100 CF-R (rotatable) with DN 160 CF-R (rotatable) with DN 160 ISO-K with weld-on pipe		842050V0001	-	-	-	
		-	-	-	842030V9004	
		842050V0002	-	842 030	-	
		-	842050V0000	-	-	842030V0001
Distance Flange - Cold stage	mm	149.5	-	148.5	111.4	-

Accessories

Compressor unit (for operation of one cold head) COOLPAK 2000, 230 V / 50 Hz COOLPAK 2200, 208 V / 60 Hz COOLPAK 6000 H, 400 V/50 Hz; 470 V / 60 Hz COOLPAK 6200 H, 400 V/50 Hz; 470 V / 60 Hz		840000V2000	-	-	-
		840000V2200	-	-	-
		-	-	840000V6001	-
		-	-	-	840000V6201
		-	-	-	-
Power supply cable				see Ordering Information for the compressor units COOLPAK	
Set of flexlines FL 4.5 (1/2", 1/2") (= 1 Set) FL 9.0 (1/2", 1/2") (= 1 Set) FL 18.0 HP (1/2") (= Single line high pressure) FL 18.0 LP (1/2") (= Single line low pressure)		892 87		892 87	
		892 88		892 88	
		840 203		840 203	
		840 204		840 204	
Connecting cable compressor – cold head Power cord 4.5 m (15.75 ft) Power cord 18 m (59.06 ft) Extension cord 4.5 m (15.75 ft)		E 400000323		E 400000323	
		840002964V0018		840002964V0018	
		893 74		893 74	

Options

Temperature measurement Silicon diode Low temperature measuring instrument Measuring cable		844000V5		844000V5	
		844 110		844 110	
		see Ordering Information low tem-		see Ordering Information low tem-	
		perature measuring instrument		perature measuring instrument	

¹⁾ The refrigerating capacities and temperatures stated apply only to vertical operation with the cold end at the bottom.

²⁾ Series 5400 from Aeroquip, coupling size "-8" (#8), or compatible types.

Dual-Stage Cold Heads

COOLPOWER 7/25 and 5/100



Dual-stage cold head COOLPOWER 7/25



Dual-stage cold heads COOLPOWER 5/100

Advantages for the User

- For installation in any orientation
- High refrigerating capacity
- No liquid refrigerants are required
- Very simple to operate
- Short cooldown time

Typical Applications

- Cooling of samples, sensors and detectors
- Cooling of detectors in astronomy
- Cooling of samples for spectroscopy
- Cooling of samples for applications in medicine and R&D
- Cooling of HTS superconductors
- Cooling in magnetic equipment
- Cooling of surfaces for pumping of gases
- Cryogenic process gas cleaning
- Condensation, resublimation and freezing of gases

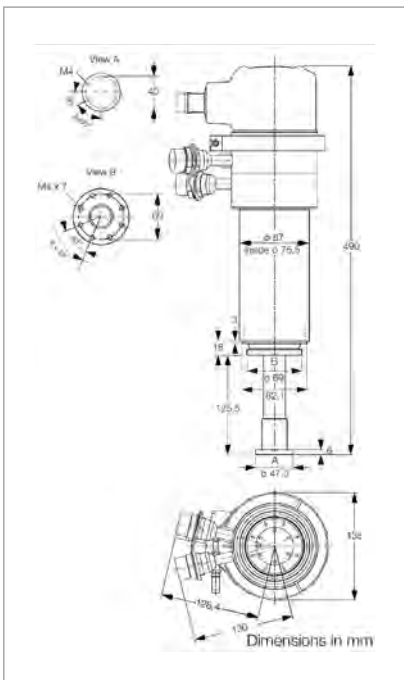

Dimensional drawing for the COOLPOWER 7/25

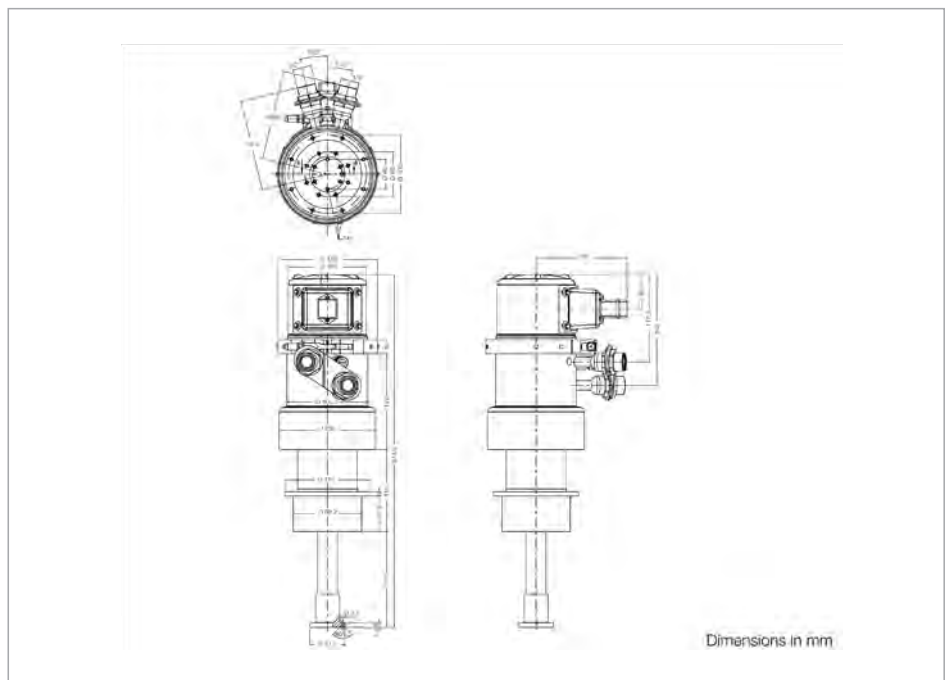

Dimensional drawing for the COOLPOWER 5/10

Technical Data

COOLPOWER 7/25

COOLPOWER 5/100

Refrigeration capacity at 50/60 Hz ¹⁾			
1st stage at 80 K, approx.	W	25	100
2nd stage at 20 K, approx.	W	7	6
Lowest attainable temperature ¹⁾			
1st stage, approx.	K	≤ 35	≤ 35
2nd stage, approx.	K	≤ 10	≤ 10
Cooldown time of the			
2nd stage to 20 K, approx.	min	35	25
Permissible ambient temperature	°C (°F)	+5 to +40 (+41 to +104)	+5 to +40 (+41 to +104)
He filling pressure at room temperature	barg	16	16
He connections			
Self-sealing screwed connections			
High pressure connection		1/2" (#8 ²⁾)	1/2" (#8 ²⁾)
Low pressure connection		1/2" (#8)	1/2" (#8)
Weight, approx.	kg (lbs)	10 (22,1)	10,5 (23,2)

Ordering Information

COOLPOWER 50

COOLPOWER 140 T

	Part No.	Part No.
Cold head		
COOLPOWER 7/25		
- with weld-on pipe	842 040	-
- with Flange DN 160 ISO-K (Space Flange – 2. Stage = 250 mm)	842 040V0002	-
- with Flange DN 100 CF-R (rotatable) (Space Flange – 2. Stage = 275 mm)	842 040V0005	-
COOLPOWER 5/100		
- with weld-on pipe	-	893 05
- with Flange DN 160 ISO-K (Space Flange – 2. Stage = 277,5 mm)	-	893 04
- with Flange DN 100 CF-R (rotatable) (Space Flange – 2. Stage = 265,5 mm)	-	842022V0001
Accessories		
Compressor unit (for operation of one cold head)		
COOLPAK 2000, 230 V / 50 Hz	840000V2000	-
COOLPAK 2200, 208 V / 60 Hz	840000V2200	-
COOLPAK 6000 H, 400 V/50 Hz; 470 V / 60 Hz	-	840000V6001
COOLPAK 6200 H, 200 V/50 Hz; 200 V, 230 V / 60 Hz	-	840000V6201
Power supply cable	-	see Ordering Information for the compressor units COOLPAK
Set of flexlines		
FL 4.5 (1/2", 1/2") (= 1 Set)	892 87	892 87
FL 9.0 (1/2", 1/2") (= 1 Set)	892 88	892 88
FL 18.0 HP (1/2") (= Single line high pressure)	840 203	840 203
FL 18.0 LP (1/2") (= Single line low pressure)	840 204	840 204
Connecting cable compressor – cold head		
Power cord 4.5 m (15.75 ft)	E 400000323	E 400000323
Power cord 18 m (59.06 ft)	840002964V0018	840002964V0018
Extension cord 4.5 m (15.75 ft)	893 74	893 74
Options		
Temperature measurement / control		
Silicon diode	844000V5	844000V5
Low temperature measuring instrument	844 110	844 110
Measuring cable	see Ordering Information low tem- perature measuring instrument	see Ordering Information low tem- perature measuring instrument

¹⁾ The refrigerating capacities and temperatures stated apply only to vertical operation with the cold end at the bottom.

²⁾ Series 5400 from Aeroquip, coupling size "-8" (#8), or compatible types.

Cold Heads, Mechanically Driven

Single-Stage Cold Head COOLPOWER 250 MD

Dual-Stage Cold Head COOLPOWER 10 MD



Single-stage Cold Head COOLPOWER 250 MD



Dual-stage Cold Head COOLPOWER 10 MD

Advantages for the User

- Excellent cooling performance
- up to 250 W at 80 K by press button operation ^{1) 2)} (COOLPOWER 250 MD)
- 18 W at 20 K by press-button operation (COOLPOWER 10 MD)
- High reliability
- Design optimized for MTBF 100,000 h
- Long and maintenance-free operation
- Low vibration due to directly driven displacer
- No liquid refrigerants are required
- Very simple to operate
- Short cooldown time
- Easy operation
- Plug & Cool – as usual for all Leybold GM coolers
- Simple variation of motor speed via the COOLPAK MD compressor unit

COOLPOWER 250 MD – one of the strongest single-stage GM cooler available on the market:

- High cooling capacity of > 175 W at 80 K
- Cooling capacity up to 250 W at 80 K possible ^{1) 2)}

COOLPOWER 10 MD - the strongest 10 K GM cooler available on the market:

- High 2nd stage cooling capacity of > 18 W at 20 K
- High 1st stage cooling capacity of > 25 W at 40 K and 110 W at 80 K

Typical Applications

The COOLPOWER 250 MD is a mechanically driven single-stage Gifford McMahon (GM) cryo cooler and ideally suited for

- Shield cooling of superconducting magnets in MRI
- Cooling of cryopanel in special Cryo pumps
- Cooling of larger samples and devices; especially
 - High temperature superconductor coils, wires and bulk materials
 - Recondensation of liquid refrigerants such as nitrogen and argon
 - Cleaning of gases
 - Samples for spectroscopic investigations in solid state and surface physics
 - Infrared and gamma detectors
- Calibration of sensors

The COOLPOWER 10 MD is a mechanically driven double-stage Gifford McMahon (GM) cryo cooler and ideally suited for

- Cooling of cryo probes in NMR spectrometers
- Shield cooling of superconducting magnets in MRI
- Cooling of cryopanel in special Cryo pumps and thus generation of high vacuum and ultra-high vacuum pressures
- Cooling of larger samples and devices; especially

- High temperature superconductor coils, wires and bulk materials
- Recondensation of liquid refrigerants such as H₂, Ne
- Samples for spectroscopic investigations in solid state and surface physics
- Infrared and gamma detectors
- Calibration of sensors

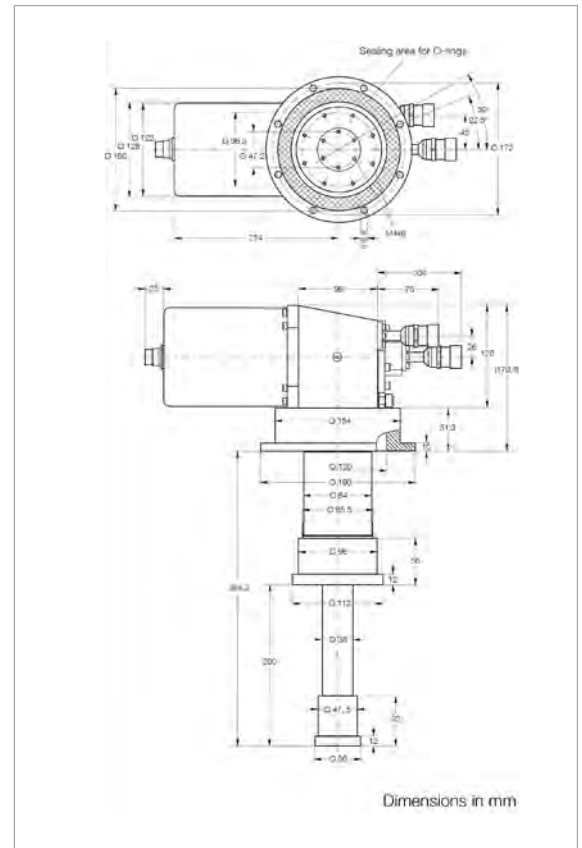
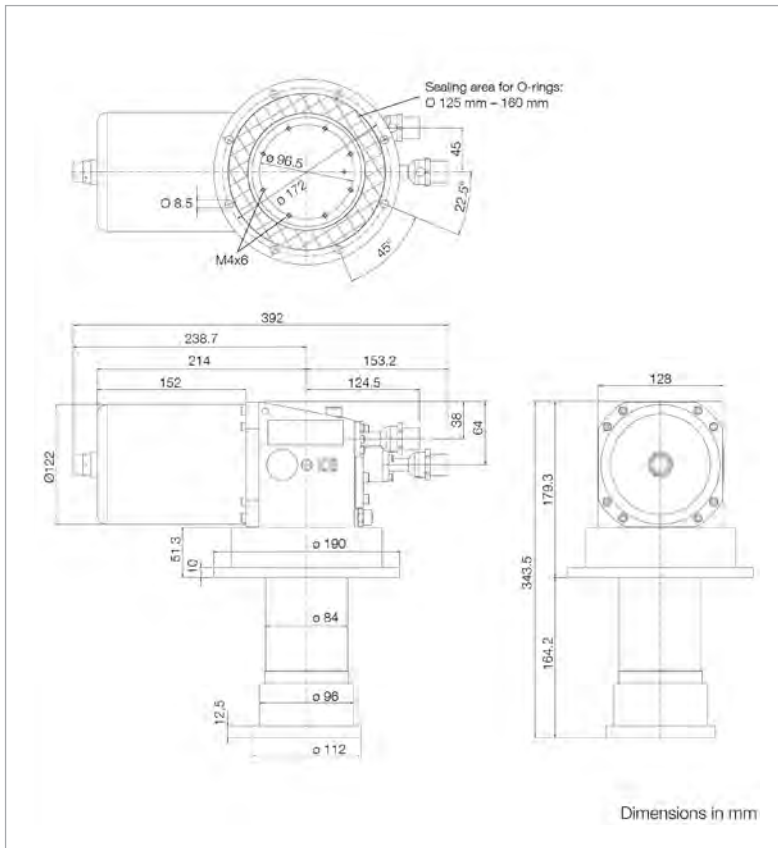

Dimensional drawing for the COOLPOWER 250 MD

Dimensional drawing for the COOLPOWER 10 MD

Technical Data

COOLPOWER 250 MD

COOLPOWER 10 MD

		COOLPOWER 250 MD	COOLPOWER 10 MD
Refrigeration capacity at 50/60 Hz ¹⁾			
1st stage at 80 K, approx.	W	175 ²⁾	110
2nd stage at 20 K, approx.	W	n/a	18
Lowest attainable temperature ¹⁾			
1st stage, approx.	K	≤ 25	≤ 28
2nd stage, approx.	K	n/a	≤ 8
Cooldown time of the			
1st stage to 80 K, approx.	min	35	n/a
2nd stage to 20 K, approx.	min	n/a	25
Permissible ambient temperature	°C (°F)	+5 to +40 (+41 to +104)	
He filling pressure at room temperature	barg	15 ₋₁	
He connections			
Self-sealing screwed connections			
High pressure connection		1/2" (#8 ²⁾)	1/2" (#8 ³⁾)
Low pressure connection		1/2" (#8)	1/2" (#8)
Weight, approx.	kg (lbs)	21 (46.3)	10,5 (48.5)

¹⁾ The refrigerating capacities and temperatures stated apply to vertical operation with the cold end at the bottom and with cold head motor rotation speed 120 RPM, He system filling pressure 13 barg, compressor unit COOLPAK 6000 HMD / 6200 HMD and mit flexlines FL 9.0 HP – DN20 (840217) and FL 9.0 LP – DN32 (840218V0032).

²⁾ Higher refrigeration capacities of up to 250 W at 80 K (CP 250 MD) can be achieved with special parameters and accessories in consultation with our technical support team.

³⁾ Series 5400 "-8" from Aeroquip.

Ordering Information
COOLPOWER 250 MD
COOLPOWER 10 MD

	Part No.	Part No.
Cold head		
COOLPOWER 250 MD	842015V0001	-
COOLPOWER 250 MD; DN 160 CF-R (rotatable)	842015V0002	-
COOLPOWER 10 MD	-	842010
COOLPOWER 10 MD; DN 160 CF-R (rotatable)	-	842010V0002
Accessories		
Compressor unit		
COOLPAK 6000 HMD, 400 V/3-ph. 50 Hz or 460 V/3-ph. 60 Hz ± 10%	840000V6002	840000V6002
COOLPAK 6200 HMD, 200 V/3-ph. 50 Hz or 200-230 V/3-ph. 60 Hz ± 10%	840000V6202	840000V6202
Power supply cable	see Ordering Information for the compressor unit COOLPAK	see Ordering Information for the compressor units COOLPAK
Flexible pressure line (for operating mechanically driven cold heads)		
9 m (31.5 ft) (High-pressure) FL9 HP-DN 20 (8f/8f)		840 217
9 m (31.5 ft) (Low-pressure) FL9 LP-DN 32 (8f/8f)		840218V0032
20 m (75.0 ft) (High-pressure) FL20 HP-DN 20 (8f/8f)		840230V2020
20 m (75.0 ft) (Low-pressure) FL20 LP-DN 32 (8f/8f)		840231V2032
Connection cable for the cold heads		
COOLPOWER 250 MD, 10 MD 0		
9,0 m		842 110
20,0 m		842 112

Compressor Units for Pneumatically Driven Cold Heads and Pumps, Water Cooling COOLPAK 2000/2200



Compressor unit COOLPAK 2000 (2200 is similar)

Advantages for the User

- High efficiency and increased performance for cryogenic pumps and refrigerators
- High long-term reliability due to long-life and highly efficient components and improved oil management
- Very quiet and low vibration operation through the innovative horizontally suspended scroll compressor
- Simple installation and operation
- Global mains voltage compatibility
- Perfect integration within complex systems due to the 24 V Sub-D interface
- Simple adsorber replacement, otherwise maintenance-free
- Small footprint
- Low cost of ownership

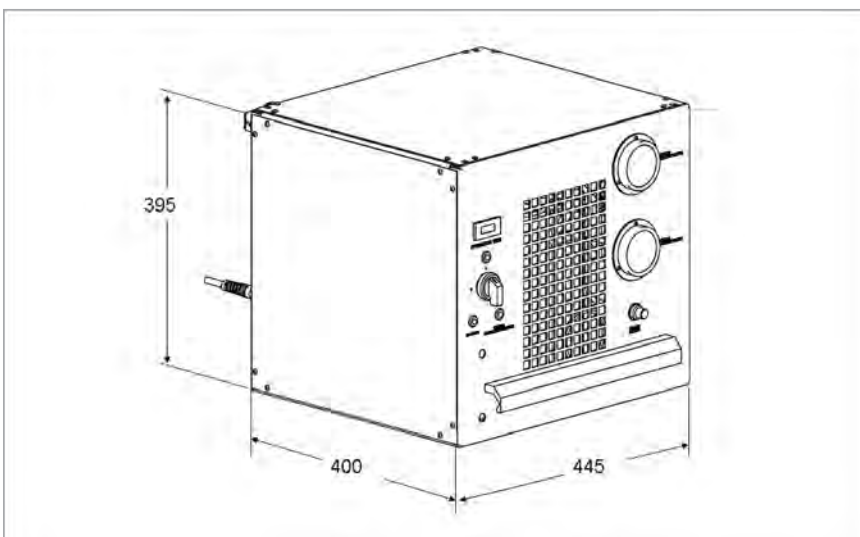

Dimensional drawing of the COOLPAK 2000/2200

Technical Data		COOLPAK 2000 (50 Hz)	COOLPAK 2200 (60 Hz)
Number of electrical connections for cold heads		1	1
Helium system filling pressure at room temperature	barg	15	14
Ambient temperature	°C (°F)	+5 to +40 (+41 to +104)	+5 to +40 (+41 to +104)
Cooling water consumption	l/min	< 5	< 5
Cooling water feed temperature	°C (°F)	+5 to +25 (+41 to +77)	+5 to +25 (+41 to +77)
Mains voltage (single phase)	V	230 ± 10%	208 ± 10%
Operating current with cooled down cold head	A	9.5 to 10.5	11.5 to 12.5
with warmed up cold head	A	12.0	13.0
Electric power consumption with cooled down cold head	kW	2.2	2.3
with warmed up cold head	kW	2.4	2.5
Remote control through interface	V DC	24	24
Helium connections			
self-sealing fittings			
high-pressure side (outside thread)		1/2" ¹⁾	1/2" ¹⁾
low-pressure side (outside thread)		1/2" ¹⁾	1/2" ¹⁾
Water connections	DN	10	10
Noise level (at a distance of 1 m (3.5 ft))	dB(A)	< 55	< 55
Dimensions (W x H x D)	mm (in.)	445 x 395 x 400 (17.52 x 15.55 x 15.74)	445 x 395 x 400 (17.52 x 15.55 x 15.74)
Weight, approx.	kg (lbs)	69 (152.32)	69 (152.32)

Ordering Information		COOLPAK 2000 (50 Hz)	COOLPAK 2200 (60 Hz)
		Part No.	Part No.
Compressor unit		840000V2000	840000V2200
Accessories, optional			
Tool-Kit		E20004779	E20004779
Spare parts			
Adsorber CPS-V8		E 840001973	E 840001973

¹⁾ Series 5400 from Aeroquip, coupling size "-8", or compatible types.

Compressor Units for Pneumatically Driven Cold Heads and Pumps, Water Cooling

COOLPAK 6000 H/6200 H/6000 HD



Compressor units COOLPAK 6000 H/6200 H/6000 HD

Used to drive cold heads with pneumatically driven displacer pistons, i.e. for individual operation of the COOLPOWER cold heads 140 T and 5/100, but also older cold heads such as the RGS 120, RGD 580 and 1245, as well as the multiplexing of COOLPOWER cold heads 50 and 7/25.

In addition, these compressors are used to operate COOLVAC cryo pumps with integrated cold heads of these types.

Advantages for the User

- Highly effective and even more powerful when connected with Leybold cryo pumps and refrigerators
- Excellent long-term reliability owing to the modular design and the long life components
- Silent and low vibration operation through scroll compressors
- Simple installation and operation
- Global power supply compatibility
- Easy integration in complex systems due to 24 V DC or RS 232 C interfaces
- Almost maintenance-free
- Small footprint
- Low cost of ownership

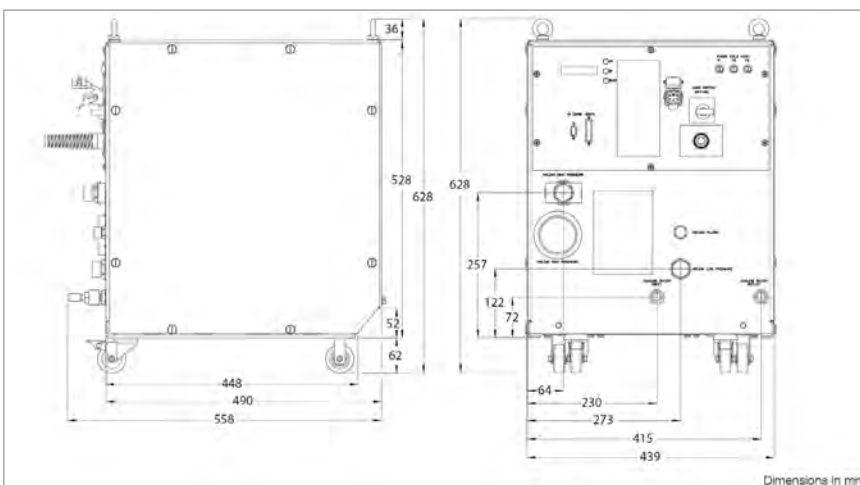

Dimensional drawing for the COOLPAK 6000 H/6200 H/6000 HD

Technical Data

COOLPAK

	6000 H / 6000 HD		6200 H	
	50 Hz	60 Hz	50 Hz	60 Hz
Number of electrical connections for cold heads	1 / 2		1	
Helium system filling pressure at room temperature barg	17	16	15	14
Ambient temperature °C (°F)	+5 to +40 (+41 to +104)			
Cooling-water consumption ¹⁾ l/min	5			
Cooling-water entry temperature °C (°F)	+5 to +25 (+41 to +77)			
Main voltage (3 phase) upon delivery V	400 ± 10%	–	230 ²⁾ + 1% / -10%	230 ± 10%
alternative setting V	–	470 ± 10%	200 ± 10%	200 ± 10%
Operating currents with cooled down cold head A	10 to 12	–	20 to 22	–
with warmed up cold head A	11 to 13	–	22 to 25	–
Electrical power consumption with cooled down cold head kW kW	6.5 to 7.5 7.0 to 8.0	7.0 to 8.0 7.5 to 8.5	6.5 to 7.5 7.0 to 8.0	7.0 to 8.0 7.5 to 8.5
Remote control via interface	24 V DC or RS 232 C			
Helium connections Self-sealing couplings High pressure connection (outside thread) Low pressure connection (outside thread)	1/2" ⁴⁾ 1/2" ⁴⁾			
Water connections	Hose nozzle DN 10 / G 1/2" outside thread			
Sound level (at 1 m (3.5 ft) distance) dB(A)	60			
Dimensions (W x H x D) mm (in.)	440 x 589 x 558 (17.32 x 23.19 x 21.97)			
Weight, approx. kg (lbs)	104 (230)			

Ordering Information

COOLPAK

	6000 H / 6000 HD		6200 H	
	50 Hz	60 Hz	50 Hz	60 Hz
	Part No.	Part No.	Part No.	Part No.
Compressor unit without power supply cable Connection for 1 cold head (CP ... H) Connection for 2 cold heads (CP ... H)	840000V6001 840000V6004		840000V6201 –	
Power supply cable CEE plug, 32 A/6h, 3-pol +N+PE, 3.5 m (12.25 ft) NEMA plug, L 16-20 P, 20 A/480 V, 3-pol +PE (AWG 12), 3.5 m (12.25 ft) - with end splice (AWG 10), 10 m (35.0 ft) - with end splice (AWG 10), 20 m (70.0 ft)	893 95 –	– 893 96	– –	840 111 840 112
Accessories Tool-Kit Water cooling discharge throttle	E 20004779 E 840000133 ³⁾		E 20004779 –	
Spare parts Adsorber CP6000H	E 840002863			

¹⁾ At a cooling water entry temperature of 25 °C (77 °F).

²⁾ At 14 barg filling pressure.

³⁾ Only for COOLPAK 6000 HD.

⁴⁾ Series 5400 from Aeroquip, coupling size "-8", or compatible types.

Compressor Units for Mechanically Driven Cold Heads and Pumps, Water Cooling COOLPAK 6000 HMD/6200 HMD



Compressor unit COOLPAK 6000 HMD/6200 HMD

Serves the purpose of individually driving the cold heads with mechanically driven displacers; i.e. COOLPOWER 250 MD and 10 MD.

In addition, these compressor units are also used for operating the COOLVAC cryo pumps 30000 BL LN₂ and COOLVAC 60000 BL LN₂.

Advantages for the User

- Highly effective and even more powerful when connected with Leybold cryo pumps and refrigerators
- Excellent long-term reliability owing to the modular design and the long life components
- Silent and low vibration operation through scroll compressors
- Small footprint
- Simple installation and operation
- Global power supply compatibility
- Easy integration in complex systems due to 24 V DC or RS 232 C interfaces
- Variable cold head motor speed, adjustable using keys on the power module or RS232C interface
- Long maintenance-free period of operation

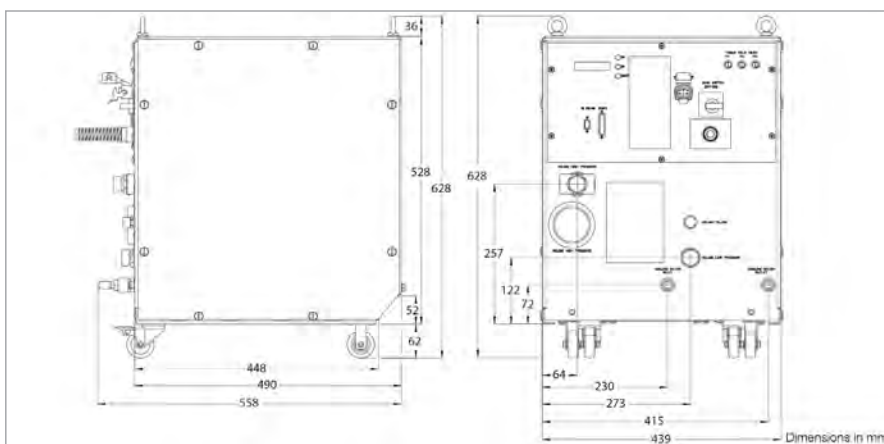

Dimensional drawing for the COOLPAK 6000 HMD/6200 HMD

Technical Data

COOLPAK

6000 HMD

6200 HMD

		50 Hz	60 Hz	50 Hz	60 Hz
Mains voltage (3 phase)	V	400 ± 10%	460 ± 10%	200 ± 10%	200 - 230 ± 10%
Helium system filling pressure at room temperature	barg	15	14	14	13
For all other Technical Data, see COOLPAK 6000 H and 6200 H					

Ordering Information

COOLPAK

6000 HMD

6200 HMD

	Part No.	Part No.
Compressor type		
400 V/3-ph. 50 Hz or 460 V/3-ph. 60 Hz ± 10%	840000V6002	-
200 V/3-ph. 50 Hz or 200 - 230 V/3-ph. 60 Hz ± 10%	-	840000V6202
Flexible pressure line (for operating mechanically driven cold heads)		
9 m (31.5 ft) (High-pressure) FL9 HP-DN 20 (8f/8f)	840 217	
9 m (31.5 ft) (Low-pressure) FL9 LP-DN 32 (8f/8f)	840218V0032	
20 m (75.0 ft) (High-pressure) FL20 HP-DN 20 (8f/8f)	840230V2020	
20 m (75.0 ft) (Low-pressure) FL20 LP-DN 32 (8f/8f)	840231V2032	
Connection cable for the cold heads COOLPOWER 250 MD, 10 MD		
09,0 m (031.5 ft)	840 111	
20,0 m (075.0 ft)	840 112	
Power supply cable		
CEE plug, 32 A/6h, 3 pol+N+PE, 3,5 m (12.25 ft)	893 95	-
NEMA plug, L 16-20 P, 20 A/480 V, 3 pol+PE (AWG 12), 3,5 m (12.25 ft)	893 96	-
10 m (35.0 ft) with end splice (AWG 10)	840 111	
20 m (70.0 ft) with end splice (AWG 10)	840 112	
Accessories		
Tool-Kit	E 20004779	
Water cooling discharge throttle	E 840000133	
Spare parts		
Adsorber CP6000H	E 840002863	

General Accessories for Compressor Units COOLPAK 2000, 6000 H

Technical Data	Length	Connections on both sides (inside thread)	
		High pressure line (HD)	Low pressure line (ND)
Flexlines ^{1), 2)}			
FL 4.5 (1/2", 1/2") (= 1 Set)	4.5 m (14.76 ft)	1/2"	1/2"
FL 9.0 (1/2", 1/2") (= 1 Set)	9,0 m (29.53 ft)	1/2"	1/2"
FL 18.0 HP (1/2") (= single high pressure line)	18 m (59.06 ft)	1/2"	-
FL 18.0 LP (1/2") (= single low pressure line)	18 m (59.06 ft)	-	1/2"

Accessories for Flexlines

Connections

(m = Outside thread, f = Inside thread)

Adaptor for flexlines		
AD (1/2" m, 3/4" f)	1/2" m	3/4" f
AD (1/2" f, 3/4" m)	3/4" m	1/2" f
90°-Elbow 1/2" for flexlines	1/2" m	1/2" f
Coupling 1/2" for interconnecting two 1/2" flexlines	1/2" m	1/2" m
Coupling 3/4"	3/4" m	3/4" m

Gas Distributors

(required quantity)

Gas Manifold – Connections

At the compressor
(Inside thread)

At the cold head
(Outside thread)

Gas manifold (1 piece each)			
GD 2 (for dual operation) 2)	2	1/2"	2 x 1/2"
GD 4 (for up to quad operation) 2)	2	1/2"	4 x 1/2"

Ordering Information

COOLPAK

	Part No.
Flexlines 1), 2)	
FL 4.5 (1/2", 1/2") (= 1 Set)	892 87
FL 9.0 (1/2", 1/2") (= 1 Set)	892 88
FL 18.0 HP (1/2") (= single high pressure line)	840 203
FL 18.0 LP (1/2") (= single low pressure line)	840 204
Adaptor for flexlines	
AD (1/2" m, 3/4" f)	892 89
AD (1/2" f, 3/4" m)	892 90
90°-Elbow 1/2" for flexlines	891 73
Coupling 1/2" for interconnecting two 1/2" flexlines	891 71
Gas manifold (1 piece each)	
GD 2 (for dual operation) ²⁾	840 253 (2x)
GD 4 (for up to quad operation) ²⁾	840 254 (2x)
Connection cable for linking cold head and compressor unit ²⁾	
Power supply cable 4.5 m (14.76 ft)	E400 000 323
Power supply cable 18 m (59.06 ft)	840 002 964V0018
Extension cable for linking cold head and compressor unit ²⁾	
EL 4.5 (4.5 m / 14.76 ft)	893 74

All flexible pressure lines, adaptor pieces, bends, isolating pieces, line couplings and gas manifolds are equipped with self-sealing Aeroquip fittings and filled in the factory with high-purity helium gas (purity: 99.999%). The filling pressure is 16 barg.

¹⁾ Minimum bending radius: 30 cm (11.81 in.).

²⁾ Only suited for pneumatically driven cold heads and cryo pumps.⁴⁾ Series 5400 from Aeroquip, coupling size "-8", or compatible types.

Accessories for Cryo Pumps / Cryogenics

Controllers and Monitoring Units for Cryo Pumps CRYOVISION

Optional Display Unit for COOLVAC iCL Cryo Pumps with COOL.DRIVE pump controller

Advantages for the User

- Visualisation of all iClassicLine cryo pump control processes with COOL.DRIVE integrated control unit via the integrated 7" (177.8 mm) touchscreen.
- Interface to customer's system controller for single or multiplex operation for cryo pumps from the iClassicLine range
- Output of measurement signals of all pressure and temperature sensors that are connected, along with the display of status reports of all pumps connected to the network
- Easily integrated within customer's system control

Typical Applications

- For automated operation of the COOLVAC cryo pumps of the iClassicLine

Control and Display Unit CRYOVISION



The intelligent control unit CRYOVISION automatically controls and monitors up to 10 COOLVAC iClassicLine cryo pumps.

Online monitoring, help functions and a service interface for ease of diagnosis and software updates via the built-in USB interface are just a few of its userfriendly features.

The CRYOVISION can be installed as a "stand alone system" or remote controlled via an interface.

Furthermore, an optional ProfiBus module is available for communication with the individual cryo pumps in single and multiplex operation via the Profi-Bus.

Technical specifications

- Deployable as a desktop unit or as a mounted unit in a 19" rack
- Operation via 7" (177.8 mm) touchscreen or rear-sided interfaces

Scope of delivery

- Stylus
- Power supply connector
- Adhesive rubber feet for use as a desktop unit
- Installation kit for 19" rack installation
- Installation and operation manual

Technical Data		CRYOVISION
Operating voltage, ±10 %	V DC	24 ¹⁾
Power consumption	W	11
Ambient temperature during operation	°C	+5 to +40
Dimensions (W x H x D)	mm (in.)	213 x 128.5 x 160 (8.39 x 5.06 x 6.3) [1/2 19" 3 HU]
Weight	kg (lbs)	1.9 (4.19)

Ordering Information		CRYOVISION
		Part No.
Control and Display Unit CRYOVISION		844231V0002
Accessories		
CRYOVISION – COOL.DRIVE / COOL.DRIVE – COOL.DRIVE		
Length	5 m (16.4 ft)	844231V2005
	10 m (32.8 ft)	844231V2010
	20 m (65.6 ft)	844231V2020
Optional Interface Module		
COOLVAC ProfiBus Module ProfiBus – RS232 converter for COOL.DRIVE und CRYOVISION		844000V1

COOLVAC ProfiBus Module

Optional ProfiBus – RS232 converter for COOLVAC iClassicLine cryo pumps with COOL.DRIVE control unit and CRYOVISION display unit

Advantages for the User

- Direct control and monitoring of the current iClassicLine range of pumps with COOL.DRIVE controllers using the ProfiBus DP protocol
- Control and monitoring of all iClassicLine cryo pumps connected to the CRYOVISION display unit on the network using the ProfiBus DP protocol
- Control and monitoring of older cryo pumps from the ClassicLine range via the corresponding COOLVAC system controller
- Configured as a top-hat rail module for straightforward rack installation.

Typical Applications

- Conversion of Profibus DP commands into RS232 commands and of RS232 response messages into Profibus DP response messages for the RS232 interfaces of the COOL.DRIVE controllers on the iClassicLine cryo pumps and/or for the RS232 interfaces of the optional CRYOVISION display unit, and for the RS232 interface of the COOLVAC system controller of the earlier COOLVAC ClassicLine range of cryo pumps.

COOLVAC ProfiBus Module



The COOLVAC ProfiBus module enables the simple and straightforward control and monitoring of cryo pumps from the current iClassicLine range and/or the earlier ClassicLine range of pumps via the RS232 interface of the attendant control and display units COOL.DRIVE and CRYOVISION or COOLVAC SC via the Profibus DP standard.

The attendant GSD file is available on our homepage.

Technical specifications

- Plastic casing, ventilated
- Combination installation feet for top-hat and C-section rails
- ProfiBus DP slave interface module
- ProfiBus DP V0 conforming to IEC 61158-2 and IEC 61784 Type 3
- ProfiBus DP address range Hex \$01...\$7D selectable via switches and \$7E selectable via software; corresponds to decimal numbers 1...126.

- ProfiBus terminating resistor can be cut in using a switch in the module
- ProfiBus connection via a 9-way D-sub socket
- RS232 interface lead connection using pluggable screw terminals

Scope of delivery

- ProfiBus module for top-hat rail installation
- 3m RS232 connection lead
- Installation and operating instructions

Technical Data		COOLVAC ProfiBus Module
Operating voltage, ±10 %	V DC	24
Power consumption, approx.	mA	90
Ambient temperature during operation	°C	+5 to +40
Dimensions (W x H x D)	mm (in.)	22.5 x 100 x 115 (0.89 x 3.94 x 4.53)
Weight	kg (lbs)	0.13 (0.29)

Ordering Information		COOLVAC ProfiBus Module
		Part No.
COOLVAC ProfiBus Module		844000V1

COOLVAC iClassicLine, Single System Configuration

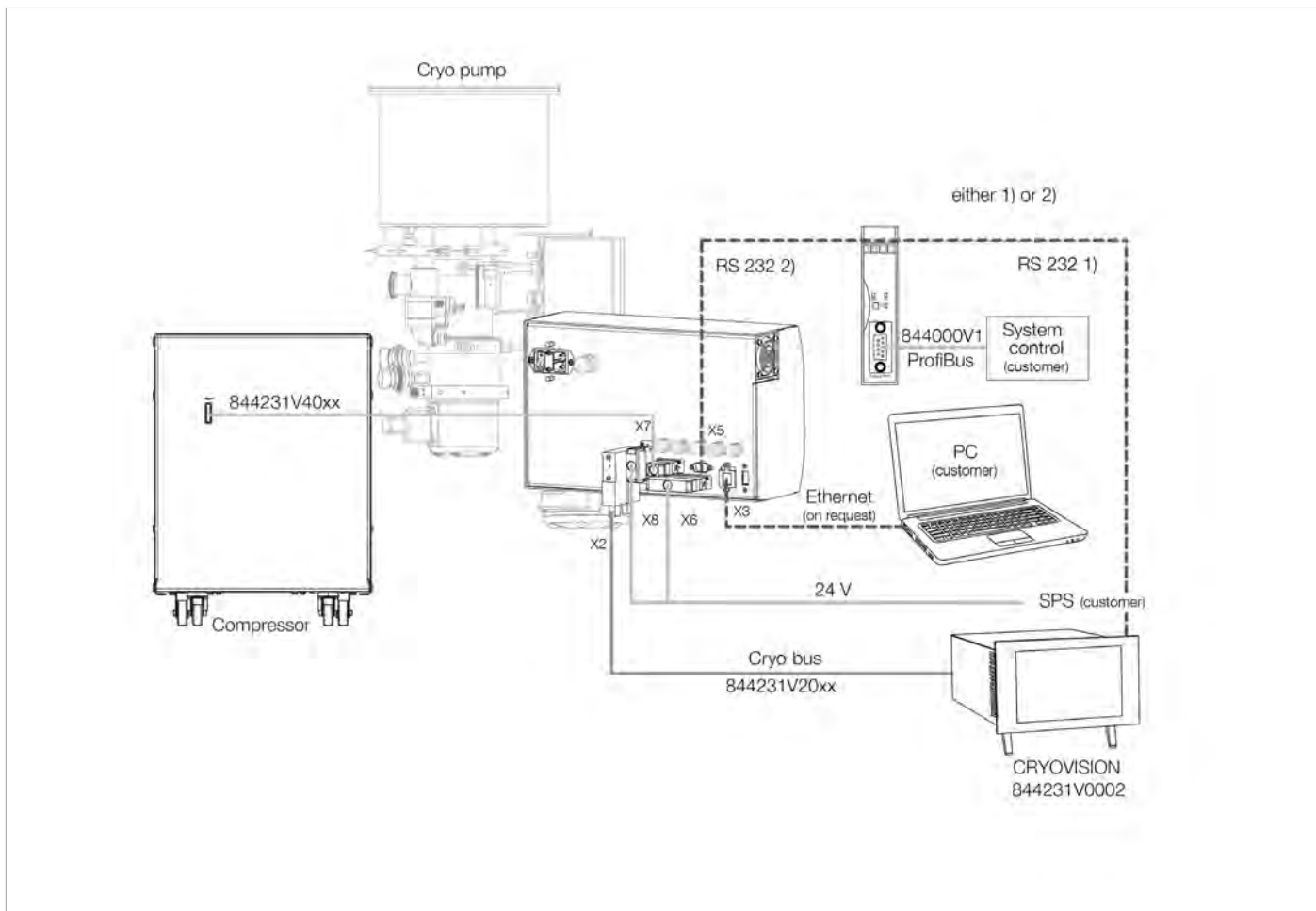

Control options for one pump and one compressor unit

COOLVAC iClassicLine, Dual and Multiple System Configuration

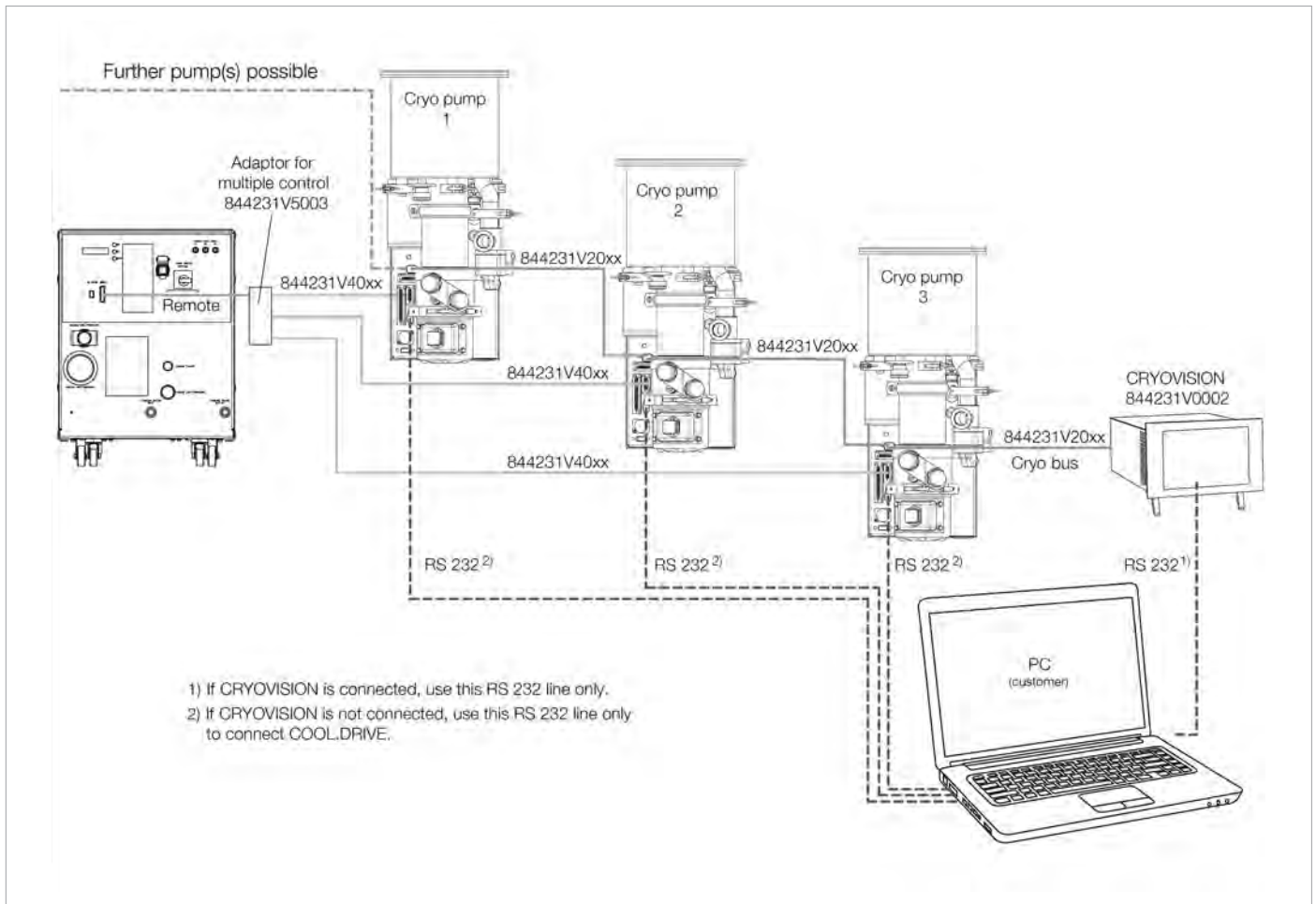

Control options for three pumps

COOLVAC iClassicLine, Dual and Multiple System Configuration

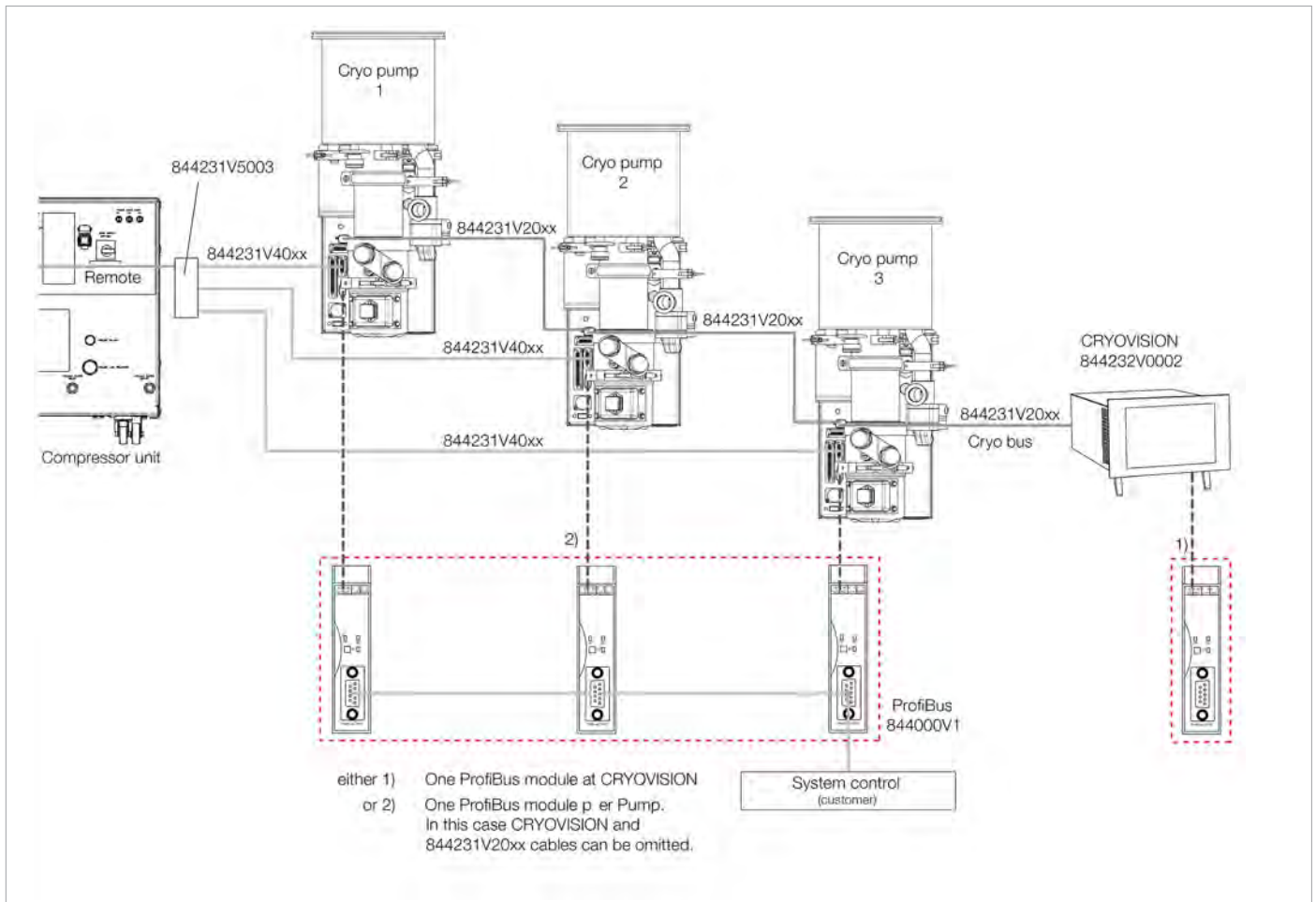

Control options for several pumps with one built-in COOL.DRIVE each

Low Temperature Measuring Instrument MODEL 211S



Advantages to the User

- Supports one silicon diode
- 3-digit LED display
- Temperature readout between 1 and 450 Kelvin
- Two trigger thresholds
- RS 232 C interface

Typical Applications

- Temperature measurements on cryostats
- Temperature measurements on cryo pumps for monitoring their operation and to control pump systems

Technical Data

		MODEL 211S
Measurement current	μA	10
Display		LED, 5-digits
Temperature range	K	1.4 to 475
Resolution		0.001 K from 1.4 to 99.9 K 0.01 K from 100 to 475 K
Accuracy		± 0.05 K from 1.5 to 99.9 K ± 0.05 K from 100 to 475 K
Power supply voltage		5 V DC at 1 A through the supplied 100 – 240 V AC power adaptor
Trigger thresholds		2
Switched output		2 relays (n.c. and n.o.) 30 V DC at 1 A
Analog output		
Voltage	V	0 to 10
Current	mA	4 to 20
RS 232 C interface		a) Temperature output b) External adjustment of switching thresholds
Admissible ambient temperature	$^{\circ}\text{C}$ ($^{\circ}\text{F}$)	+15 to +35 (+59 to +95)
Mechanical design/housing		Benchtop unit
Dimensions (W x H x D)	mm	96 x 48 x 166 (3.78 x 1.89 x 6.54)
Weight (including packaging), approx.		0.45 (1.0)

Ordering Information

MODEL 211S

	Part No.
Low temperature measuring instrument MODEL 211S	844 110
HV cable 2-way with plug, 10 m (35.0 ft) long 1	844 112
HV cable 4-way with plug, 10 m (35.0 ft) long 2)	844 113
UHV cable 4-way with plug, 10 m (35.0 ft) long 2)	844 114
Silicon diode, type E, with connecting cable and micro plugs 4) without current feedthrough	844000V5
HV current feedthrough on a flange DN 25 KF, 2-way 5)	E20019256
UHV current feedthrough on a flange DN 16 CF, 4-way 6)	500 217

¹⁾ Compatible with HV current feedthrough on a flange DN 25 ISO-KF (E20019256) and for older cryo pumps of type RPK.

²⁾ Compatible with current ranges BasicLine (BL) and BL LN₂.

³⁾ Compatible with UHV current feedthrough on a flange DN 16 CF (500217) and cryo pumps from the BL-UHV range.

⁴⁾ Compatible with HV current feedthrough (E20019256).

⁵⁾ Compatible with 844000V5 and measurement line 844112.

⁶⁾ Compatible with measurement line 844114.

Temperature Sensor

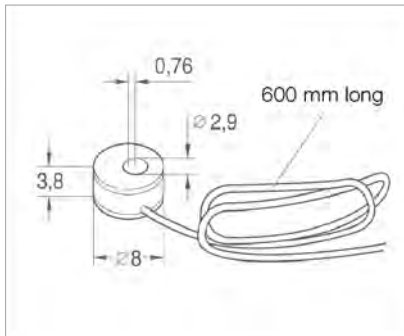

Dimensional drawing for the silicon diode, type E

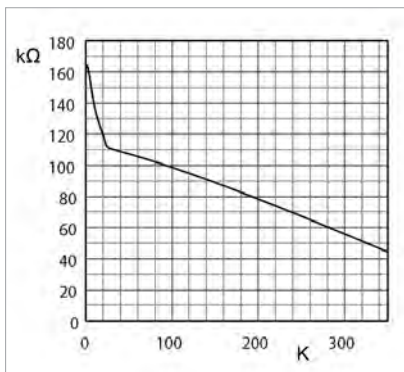

Standard characteristic of the silicon diode

In contrast to vapor pressure thermometers, electric temperature sensors can be used for continuous measurements within a wide range of temperatures.

Silicon diodes offer a negative temperature coefficient of resistance, i.e. their resistance drops as the temperature increases. The slope of the temperature/ resistance characteristic and the absolute resistance are decisive regarding the suitability of these diodes. The slope determines the sensitivity of the sensor and a high electrical resistance permits accurate measurements while keeping the thermal load small (microwatts).

In systems which are degassed at high temperatures, silicon diodes can only be fitted after degassing has been completed.

The silicon diode type E matches the low temperature display unit.

Technical Data

Silicon Diode Type E

Temperature range	K	1.4 to 325
Temperature coefficient (dR/dT) qualitative		Negative in the entire temperature range
quantitative	Ω/K	Non-linear characteristic
Measurement current	μA	10
Bakeable to	$^{\circ}C$ ($^{\circ}F$)	+60 (+140)

Ordering Information

Silicon Diode Type E

	Part No.
Temperature sensor	844000V5
Silicon diode with 4-way electrical feedthrough	E6512948

