

# Oil Sealed Vacuum Pumps

## TRIVAC

Rotary Vane Vacuum Pumps

## NEO D

Rotary Vane Vacuum Pumps

## SOGEVAC

Rotary Vane Vacuum Pumps

## VACUBE

Screw Vacuum Pumps

# Contents

## Oil Sealed Vacuum Pumps

<b>TRIVAC Rotary Vane Pumps .....</b>	<b>6</b>
<b>General</b>	
Applications for TRIVAC pumps .....	6
Accessories for TRIVAC pumps .....	7
Oil for TRIVAC pumps .....	8
for different fields of application .....	8
for different pump types .....	9
<b>Products</b>	
Small Compact Pump S 1,5 .....	10
<b>TRIVAC E, Oil Sealed Rotary Vane Vacuum Pump .....</b>	<b>12</b>
<b>TRIVAC D 2,5 E .....</b>	<b>13</b>
<b>TRIVAC B, Two-Stage Rotary Vane Vacuum Pump .....</b>	<b>16</b>
TRIVAC D 16 B-DOT to D 40 B-DOT .....	17
TRIVAC D 16 B-Ex, Explosion Protected .....	18
TRIVAC D 4 B and D 8 B .....	19
TRIVAC D 16 B and D 25 B .....	23
TRIVAC D 40 B and D 65 B .....	26
TRIVAC D 16 B-DOT to D 40 B-DOT .....	30
TRIVAC D 16 B-Ex (Explosion Protected and Pressure Burst Resistant) .....	34
<b>TRIVAC BCS, Two-Stage Rotary Vane Vacuum Pumps .....</b>	<b>36</b>
TRIVAC D 16 BCS to D 65 BCS .....	38
TRIVAC D 16 BCS-PFPE to D 65 BCS-PFPE .....	42
Motor Dependent Data .....	46
<b>Accessories</b>	
For TRIVAC E, B and BCS .....	51
Exhaust Filters AF 8 to AF 25-S .....	51
Condensate Traps AK 8 to AK 25 .....	51
Exhaust Filters .....	53
AF 4-8 to AF 40-65 .....	53
AF 16-25 DOT and AF 40-65 DOT .....	53
Exhaust Filters with Lubricant Return .....	55
ARP 4-8 and AR 4-8 to AR 40-65 .....	55
ARS 16-25 and ARS 40-65 .....	56
Oil Drain Tap .....	57
Condensate Separators AK 4-8 to AK 40-65 .....	58
Dust Filters DN 16 KF to DN 40 KF .....	59
Adsorption Traps DN 16 KF to DN 40 KF .....	60

Cold Trap TK 4-8 .....	61
Dust Separators AS 8-16 and AS 30-60 .....	62
Mechanical Oil Filters OF 4-25 and OF 40-65 .....	63
Chemical Oil Filters CF 4-25 and CF 40-65 .....	63
Chemical Filters with Safety Isolation Valve	
CFS 16-25 and CFS 40-65 .....	65
Inert Gas System IGS 16-25 and IGS 40-65 .....	66
Limit Switch System	
LSS 16-25 and LSS 40-6 .....	67
Roots Pump Adaptor .....	68
SE Smoke Eliminator .....	69
<b>General Accessories</b>	
Flange Components, Valves .....	70
<b>Miscellaneous</b>	
Services .....	71
60 Hz Curves .....	76
<b>NEO D Rotary Vane Vacuum Pumps .....</b>	<b>77</b>
<b>General</b>	
Applications for NEO D pumps .....	77
Oil for NEO D pumps .....	78
Product Range, Features and Design .....	79
<b>Products</b>	
NEO D 16 / D 25 / D 40 / D 65 .....	81
<b>SOGEVAC Rotary Vane Vacuum Pumps .....</b>	<b>84</b>
<b>General</b>	
Applications for SOGEVAC pumps .....	84
Oil for SOGEVAC pumps .....	85
for different fields of application .....	85
for different pump types .....	86
Product Range, Features and Design .....	87
<b>Products</b>	
SOGEVAC SV 10 B / SV 16 B .....	89
SOGEVAC SV 16 D / SV 16 DI / SV 25 D. ....	91
SOGEVAC SV 25 B .....	95
SOGEVAC SV 40 B / SV 65 B .....	97
SOGEVAC SV 100 B .....	101
SOGEVAC SV 120 B .....	105
SOGEVAC SV 220 B .....	109
SOGEVAC SV 300 B and 320 B .....	113

SOGEVAC SV 630 B/630 BF/750 B/750 BF .....	121
SOGEVAC SV 28 BI .....	125
SOGEVAC SV 40 BI .....	129
Pumps Prepared with PFPE for	
Use with Oxygen .....	131
SOGEVAC SV 40 ATEX .....	133
ATEX Category 2 Pumps .....	137
ATEX Category 3 Pumps .....	139
<b>Accessories</b>	
Dust Filters (Suction Side) .....	141
Dust Filters F (Suction Side) .....	143
LS Separators .....	145
Gas Ballast Valve .....	147
Thermal Switch .....	147
Mobile Base Frame .....	149
Noise Enclosure .....	150
Mounting Accessories .....	151
Exhaust Filter Gauge .....	152
Single Phase Power Supply Cables .....	153
Ball Valves and Valves .....	155
Bourdon Vacuum Gauges DIAVAC DV 1000 .....	157
Connection Fittings for SOGEVAC .....	159
SV 10 B, SV 16, SV 16 B, SV 16 D,SV 25, SV 25 B, SV 25 D .....	159
SOGEVAC SV 40 B, SV 65 B, SV 100 B .....	161
SOGEVAC SV 220 B, SV 300 B, SV 320 B .....	163
SV 630 B(F), SV 750 B(F) .....	165
60 Hz Curves .....	167
Combination Filter .....	173
Vacuum Pump Inlet Filter .....	173

<b>VACUBE Screw Vacuum Pumps .....</b>	<b>175</b>
<b>Products</b>	
<b>Oil-sealed Screw Vacuum Pumps .....</b>	<b>175</b>
VACUBE VQ 400 i to VQ 4800 iH .....	175
On-Board Controllers .....	176
Central Controller Multi-VAControl .....	176
VACUBE 400 to 800 m <sup>3</sup> /h .....	177
VACUBE 1250 to 1650 m <sup>3</sup> /h .....	179
VACUBE 3600 to 4800 m <sup>3</sup> /h .....	181

# General

## Applications for TRIVAC pumps

Pumps	S 1,5	TRIVAC D 2,5 E	TRIVAC D 4 B	TRIVAC D 8 B	TRIVAC D 16 B	TRIVAC D 25 B	TRIVAC D 40 B	TRIVAC D 65 B	TRIVAC D 16 B-DOT und D 25 B-DOT	TRIVAC D 40 B-DOT	TRIVAC D 16 B-Ex	TRIVAC D 16 BCS und D 25 BCS	TRIVAC D 40 BCS	TRIVAC D 65 BCS	TRIVAC D 16 und D 25 BCS-PFPE	TRIVAC D 40 BCS-PFPE	TRIVAC D 65 BCS-PFPE
<b>Applications</b>																	
Production of semiconductors									■	■	■	■	■	■	■		
Vacuum coating			■	■	■	■			■	■	■	■	■	■	■		
Research and development	■	■	■	■	■	■	■			■	■	■	■	■	■		
Chemistry/ pharmaceuticals		■		■	■	■	■			■	■	■	■	■	■		
Metallurgy/ furnaces						■	■										
Automotive industry		■		■	■			■	■								
Space simulation						■	■										
Analytical engineering		■	■	■	■	■											
Environment engineering		■	■	■	■	■	■										
Cooling and air-conditioning	■		■	■	■	■			■								
Electrical engineering	■	■	■	■	■	■	■										
Mechanical engineering	■	■	■	■	■	■	■										
Medicine technology		■	■	■	■	■											
Vacuum drying cabinets		■	■	■	■	■			■	■	■						
Chemistry and research labs		■	■	■	■	■											
Freeze drying systems		■	■	■	■	■	■		■	■	■	■	■	■	■	■	■
Backing pump for high vacuum pump systems	■	■	■	■	■	■	■										
Leak detectors		■			■	■	■										

## Applications for TRIVAC pumps

Pumps	S 1,5	TRIVAC D 2,5 E	TRIVAC D 4 B	TRIVAC D 8 B	TRIVAC D 16 B	TRIVAC D 25 B	TRIVAC D 40 B	TRIVAC D 65 B	TRIVAC D 16 B-DOT + D 25 B-DOT	TRIVAC D 40 B-DOT	TRIVAC D 16 B-Ex	TRIVAC D 16 BCS + D 25 BCS	TRIVAC D 40 BCS	TRIVAC D 65 BCS	TRIVAC D 16 + D 25 BCS-PFPE	TRIVAC D 40 BCS-PFPE	TRIVAC D 65 BCS-PFPE
<b>Applications</b>																	
Exhaust filters AF (-DOT)		■	■	■	■	■	■	■	■			■	■	■			
Condensate traps / separators AK	■	■	■	■	■	■	■	■				■	■	■	■	■	■
Exhaust filters with lubricant return ARP / AR				■	■	■	■	■	■			■	■	■			
Exhaust filters with lubricant return ARS												■	■	■	■	■	■
Exhaust filter drain tap		■															
Oil drain tap	■	■	■	■	■	■	■	■	■	■	■	■	■	■	■	■	■
Dustfilter FH/DF DN 16 to 40 KF	■	■	■	■	■	■	■	■				■	■	■	■	■	■
Adsorption trap FH/RF DN 16 to 40 KF	■	■	■	■	■	■	■	■				■	■	■	■	■	■
Cold trap TK		■	■	■													
Dust separators AS	■	■	■	■	■	■	■	■				■	■	■	■	■	■
Molecular filters MF	■	■	■	■	■	■	■	■				■	■	■	■	■	■
Mechanical oil filters OF			■	■	■	■	■	■									
Chemical oil filters CF			■	■	■	■	■	■				■	■	■	■	■	■
Chemical filters with safety isolation valve CFS		■	■	■	■	■						■	■	■	■	■	■
Inert gas system IGS												■	■	■	■	■	■
Limit switch system LSS												■	■	■	■	■	■
Roots pump adaptor							■	■				■	■		■	■	
Flange components, valves	■	■	■	■	■	■	■	■	■	■	■	■	■	■	■	■	■

# Oil for TRIVAC pumps for different fields of applicationa

Applications	Semiconductor production	Vacuum coating	Research and development	Chemistry/Pharmaceutical	Metallurgy/Furnaces	Lamps and tubes manufactures	Automotive industry	Laser technology	Space simulation	Analytical engineering	Environmental engineering	Oxygen technologies	Cooling applications	Electrical engineering	Mechanical engineering	Medicine technology	Vacuum drying cabinets	Chemistry and research labs	Freeze drying	Backing pump for HV pump systems	Food industry
<b>LEYBONOL Oils</b>																					
LVO 130	▲	■	■	■	■	■	■	■	■	■	■	■	■	■	■	■	■	■	■	■	■
LVO 210		■	■	■	■	■	■	■	■	■	■	■	■	■	■	●	■	●	●		
LVO 240			■	■																	
LVO 300																					■
LVO 310			■	■	■	■				■		■									▲
LVO 400	■	●	■	■						■						▲	●		●		
DOT 4			●			■															

- = Standard
- = Possible
- ▲ = Please contact Leybold

The table only lists general applications. Your specific requirements might be subject to deeper analysis. For further questions, please contact our technical Sales support.

**For information on oil specifications please refer to Catalog Part "Oils / Greases / Lubricants LEYBONOL®".**

# Oil for TRIVAC pumps for different pump types

Pump	S 1,5	TRIVAC D 2,5 E	TRIVAC D 4 B	TRIVAC D 8 B	TRIVAC D 16 B	TRIVAC D 25 B	TRIVAC D 40 B	TRIVAC D 65 B	TRIVAC 40 B-DOT	TRIVAC D 65 B <sup>3</sup> He	TRIVAC D 16 B-Ex	TRIVAC D 16 BCS and D 25 BCS	TRIVAC D 40 BCS	TRIVAC D 65 BCS	TRIVAC D 16 and D 25 BCS-PFPE	TRIVAC D 40 BCS-PFPE	TRIVAC D 65 BCS-PFPE
<b>LEYBONOL Oils</b>																	
LVO 130	■	■	■	■	■	■	■		■	■	■	■	■				
LVO 210	●	●	●	●	●	●	●			●	●	●	●				
LVO 240	●	●	●	●	●	●	●		▲			●					
LVO 300			●	●	●	●	●										
LVO 310	●	●	●	●	●	▲			▲								
LVO 400		▲	▲										■	■	■		
DOT 4							■	■									

- = Standard
- = Possible
- ▲ = Please contact Leybold

The table only lists general applications. Your specific requirements might be subject to deeper analysis. For further questions, please contact our technical Sales support.

**For information on oil specifications please refer to Catalog Part "Oils / Greases / Lubricants LEYBONOL®".**

# Products

## Small Compact Pump S 1,5



The S 1,5 is a single-stage, oil sealed rotary vane pump with a gas ballast valve. It is driven by a flange mounted AC motor. The shaft of the pump and the shaft of the motor are linked by means of a pinned coupling.

### Advantages to the User

- Very small and light-weight
- Low ultimate pressure
- High water vapor tolerance
- Low noise operation
- Simple to connect
- Easy to maintain and use

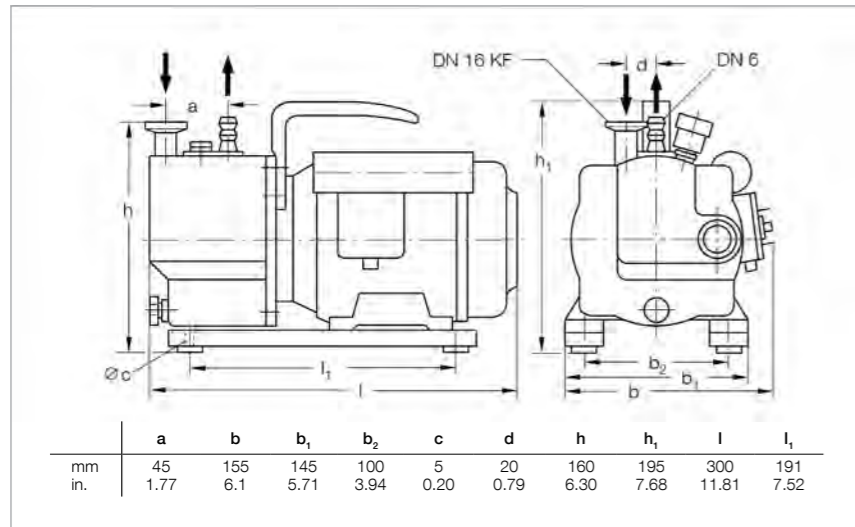

Dimensional drawing for the S 1,5

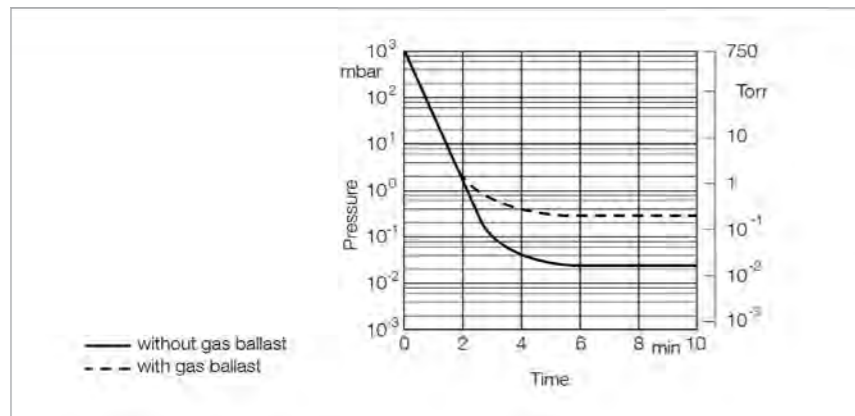

Pump-down characteristics of a 10 l vessel at 50 Hz

### Typical Applications

- In all areas of vacuum engineering where a low intake pressure is required
- Evacuation of refrigerant circuits
- For suction, lifting, emptying, filling and tensioning
- For installation in mobile instruments

### Supplied Equipment

- DN 16 small flange connection on the intake side
- Centering ring and clamping ring
- Exhaust port designed as a DN 6 hose nozzle
- Carrying handle
- Built-in ON/OFF switch and overcurrent circuit breaker
- Oil filling

### Technical Data

		S 1,5	
		50 Hz	60 Hz
Nominal pumping speed <sup>1)</sup>	m <sup>3</sup> /h (cfm)	1.9 (1.1)	2.3 (1.3)
Pumping speed <sup>1)</sup>	m <sup>3</sup> /h (cfm)	1.75 (1)	2.1 (1.2)
Ultimate partial pressure without gas ballast <sup>1)</sup>	mbar (Torr)	3 x 10 <sup>-2</sup> (2.3 x 10 <sup>-2</sup> )	3 x 10 <sup>-2</sup> (2.3 x 10 <sup>-2</sup> )
Ultimate total pressure with gas ballast <sup>1)</sup>	mbar (Torr)	5 x 10 <sup>-1</sup> (3.8 x 10 <sup>-1</sup> )	5 x 10 <sup>-1</sup> (3.8 x 10 <sup>-1</sup> )
Water vapor tolerance <sup>1)</sup>	mbar (Torr)	> 15 (> 11.3)	> 15 (> 11.3)
Water vapor capacity	g/h (lbs/h)	19 (42)	23 (50)
Oil filling, min. / max.	l (qt)	0.11/0.14 (0.12/0.15)	0.11/0.14 (0.12/0.15)
Noise level to DIN 45 635	dB(A)	50	50
Admissible ambient temperature	°C (°F)	12 – 40 (53.6 – 104)	12 – 40 (53.6 – 104)
Max. permanent inlet pressure	mbar (Torr)	30 (22.5)	30 (22.5)
Motor rating	W (hp)	250 (0.34)	250 (0.34)
Nominal speed	rpm	1500	1800
Weight	kg (lbs)	8.8 (19.4)	8.8 (19.4)
Connections			
Intake	DN	16 KF	16 KF
Exhaust		6 mm hose nipple	6 mm hose nipple

### Ordering Information

	Part No.
S 1,5 with AC motor, 230 V (208 – 252 V ± 5%), 50/60 Hz, with 2 m long mains cord and EURO plug	<b>101 01</b>
Transition connector (250 V AC, 10 A, L+N+PE) only necessary in Switzerland for 1~ pumps	<b>800 001 274</b>
AK 8 condensate trap	<b>190 60</b>
Connection components	
Elbow (1x) DN 16 KF	<b>184 36</b>
Centering ring with O-ring (2x) DN 16 KF	<b>183 26</b>
Clamping ring (2x) DN 16 KF	<b>183 41</b>

<sup>1)</sup> To DIN 28 400 and following numbers

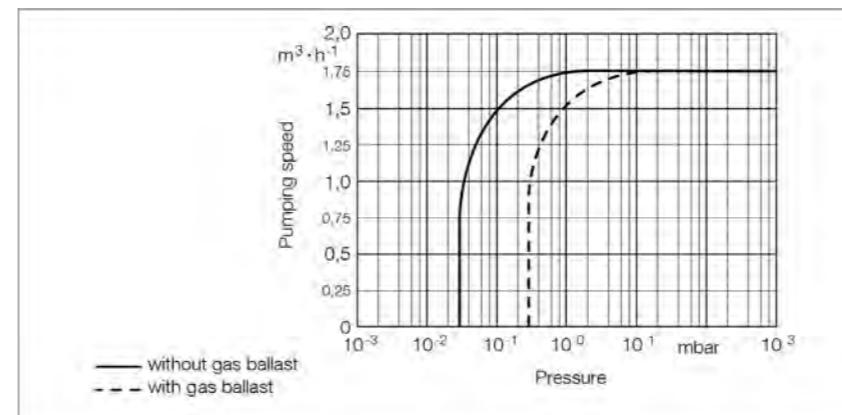

Pumping speed characteristics at 50 Hz

# TRIVAC E, Two-Stage, Oil Sealed Rotary Vane Vacuum Pump



TRIVAC D 2,5 E

The TRIVAC E pump is an oil sealed vacuum pump operating according to the rotary vane principle. Oil which is injected into the pump chamber is used for sealing, lubrication and cooling purposes.

The result is the TRIVAC E rotary vane vacuum pump.

Beyond the usual quality and reliability of the B series pumps, the TRIVAC E pump offers improvements in the area of quieter operation, smaller size and improved service-friendliness.

The intake and exhaust ports are equipped with small flanges. Besides standard voltages and frequencies, Leybold offers world motors, which are specially required by OEMs.

### Advantages to the User

- Highly reliable
- Small and compact
- Quiet operation
- Environmentally compatible (low oil consumption, EMI compatible, IP 54 protection)
- Process quality (low backstreaming of oil)
- Motor for all standard supply voltages and frequencies
- Safe and intelligent vacuum protection (hermetically sealed)
- Free of yellow metals
- Compliance with international standards (CE)
- Suitable for continuous operation at 1000 mbar (750 Torr) with exhaust filter & oil return
- Low power consumption
- Better individual performance given by 3 stage gas ballast device
- High water vapor tolerance
- Simplified customizing ability

### Typical Applications

- Mass and X-ray spectrometers
- Electron beam microscopes
- Leak detectors
- Sterilizers
- Freeze-drying systems
- Chemical and research labs
- General vacuum engineering
- Backing pump for high vacuum pump systems

### Supplied Equipment

- Dirt trap
- Oil filling included separately
- Gas ballast device
- Mains cord with the specific plug for EURO, US and Japan motors
- Optional: Mains cord with country specific plug for the world motor
- With handle

All pumps are 100% subjected to a vacuum test before delivery!

# TRIVAC D 2,5 E

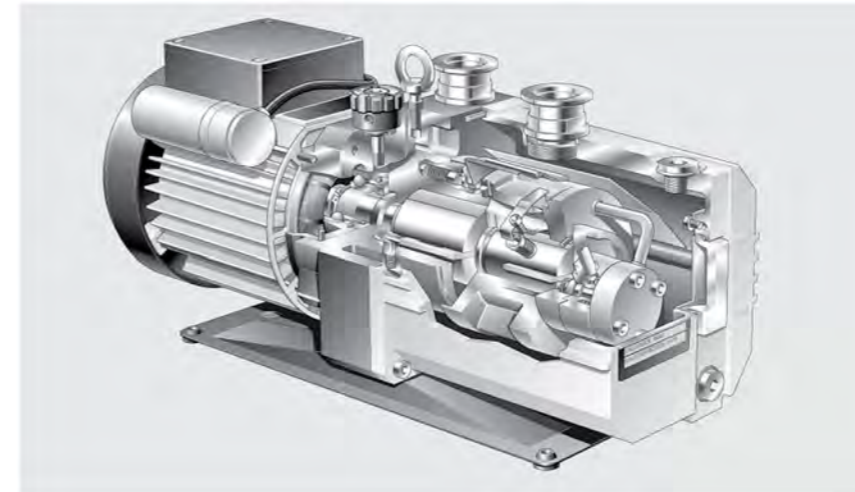

TRIVAC E

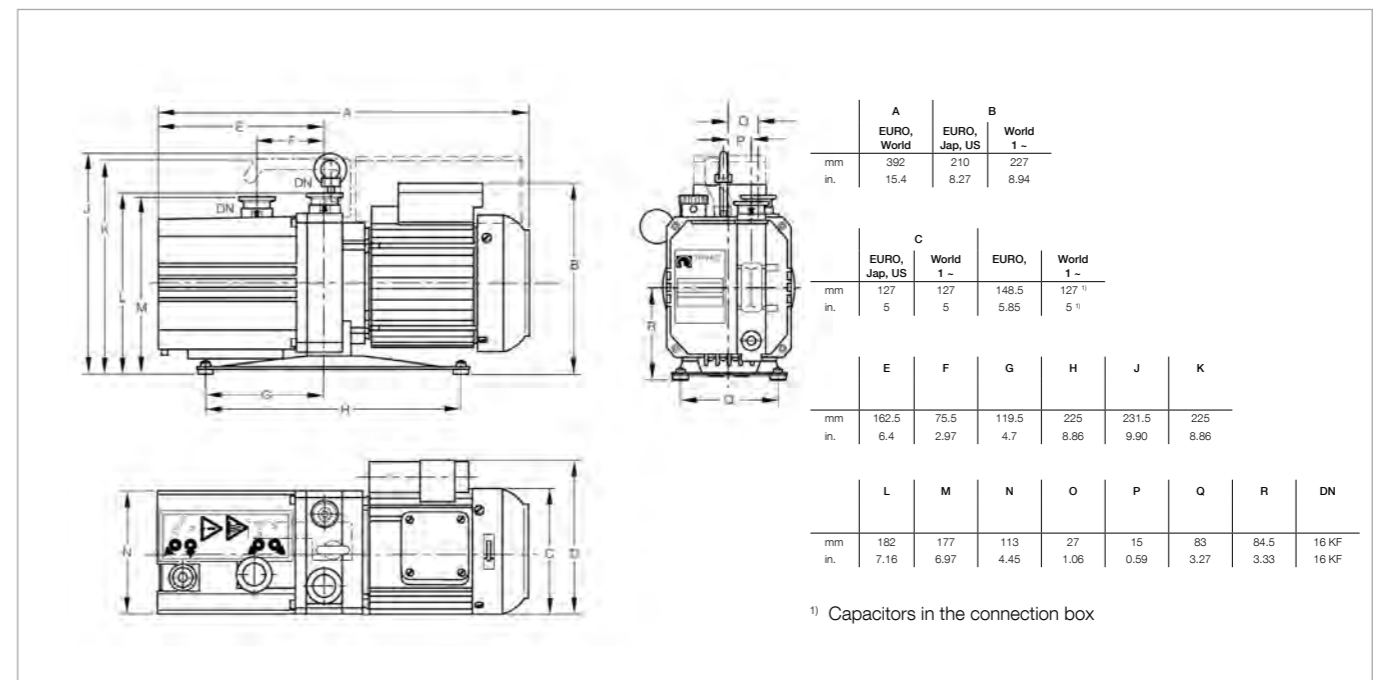

Dimensional drawing for the TRIVAC D 2,5 E

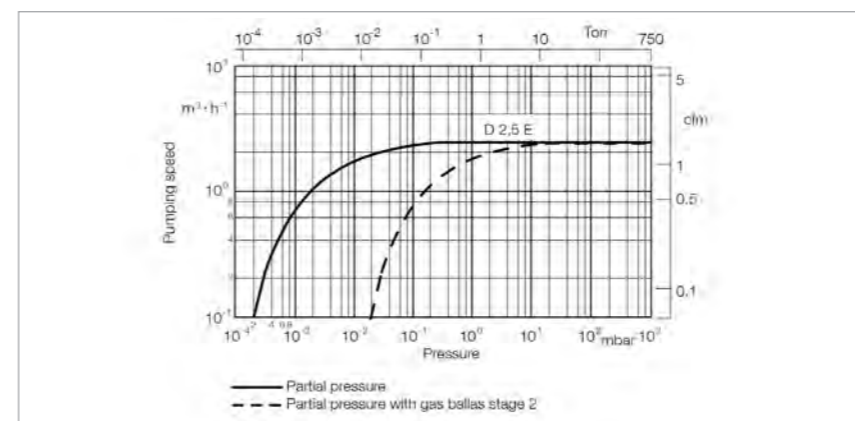

Pumping speed of the TRIVAC D 2,5 E at 50 Hz (60 Hz curves at the end of the chapter)

## Technical Data

## TRIVAC D 2,5 E

		50 Hz	60 Hz
Nominal pumping speed <sup>1)</sup>	m <sup>3</sup> /h (cfm)	3.2 (1.9)	3.6 (2.1)
Pumping speed <sup>1)</sup>	m <sup>3</sup> /h (cfm)	2.7 (1.6)	3.3 (1.9)
Ultimate partial pressure without gas ballast <sup>1)</sup>	mbar (Torr)	≤ 5 × 10 <sup>-4</sup> (≤ 3.8 × 10 <sup>-4</sup> )	≤ 5 × 10 <sup>-4</sup> (≤ 3.8 × 10 <sup>-4</sup> )
Ultimate partial pressure without gas ballast <sup>2)</sup>	mbar (Torr)	≤ 2 × 10 <sup>-3</sup> (≤ 1.5 × 10 <sup>-3</sup> )	≤ 2 × 10 <sup>-3</sup> (≤ 1.5 × 10 <sup>-3</sup> )
Ultimate total pressure with gas ballast Stage 2 <sup>2)</sup>	mbar (Torr)	≤ 3 × 10 <sup>-2</sup> (≤ 2.3 × 10 <sup>-2</sup> )	≤ 3 × 10 <sup>-2</sup> (≤ 2.3 × 10 <sup>-2</sup> )
Water vapor tolerance			
Stage 1	mbar (Torr)	10 (7.5)	10 (7.5)
Stage 2	mbar (Torr)	20 (15)	20 (15)
Stage 3	mbar (Torr)	30 (22.5)	30 (22.5)
Water vapor capacity			
Stage 1	g/h (lbs/h)	20 (0.044)	25 (0.055)
Stage 2	g/h (lbs/h)	40 (0.088)	50 (0.110)
Stage 3	g/h (lbs/h)	60 (0.132)	75 (0.165)
Oil filling, min. / max.	l (qt)	0.4 / 0.7 (0.42 / 0.74)	0.4 / 0.7 (0.42 / 0.74)
Noise level	dB(A)	≤ 47	≤ 49
Admissible ambient temperature	°C (°F)	+10 to +40 (+50 to +104)	+10 to +40 (+50 to +104)
Motor rating	W (HP)	280 (0.38)	300 (0.41)
Nominal speed	rpm	1400	1600
Type of protection	IP	54	54
Weight (with oil filling)	kg (lbs)	16.1 (35.4)	16.1 (35.4)
Connections (Intake and Exhaust)	DN	16 KF	16 KF

<sup>1)</sup> To DIN 28 426 T1

<sup>2)</sup> To DIN 28 400 and following numbers

## Motor Dependent Data

Motors for D 2,5 E	Voltage (V)	Frequency (Hz)	Voltage tolerance	Power consumption (W (HP))	Nominal current (A)	Protection	Nominal speed (rpm)
EURO 1 ~	220–240/230	50/60	± 5%	280/300 (0.38/0.41)	1.8/1.4	IP 54	1400/1600
World 1 ~	100–120 200–240	50/60	± 5%	290/310 (0.39/0.42)	4.4/3.0 2.2/1.5	IP 54	1400/1600

## Ordering Information

## TRIVAC D 2,5 E

	Part No.
TRIVAC E with 1.8 m (6 ft.) long mains cord EURO version, 1-ph., 220 – 240 V, 50 Hz; 230 V, 60 Hz Schuko plug	<b>140 000</b>
CH plug	<b>140 005</b>
Single phase world motor, 100 – 120 V, 200 – 240 V 50/60 Hz (without mains cord)	<b>140 001</b>
Further variants upon request	
<b>Accessories</b>	
Connection cable for single phase world motor 230 V Schuko plug	<b>E20081091</b>
230 V UK plug	<b>E20081097</b>
230 V CH plug	<b>E20081099</b>
230 V NEMA plug (200 – 240 V)	<b>E20081141</b>
115 V NEMA plug (100 – 120 V)	<b>E20081090</b>
Exhaust filter AF 8	<b>190 50</b>
Replacement filter elements FE 8 for AF 8 (pack of 5)	<b>ES19080</b>
Condensate trap AK 8	<b>190 60</b>
Oil drain tap (M 16 x 1.5)	<b>190 90</b>
Connection components Elbow (1x) DN 16 KF Centering ring with O-ring (2x) DN 16 KF Clamping ring (2x) DN 16 KF	<b>184 36</b> <b>183 26</b> <b>183 41</b>
<b>Spare Parts</b>	
Maintenance kit 1 (oil demister, oil box seal)	<b>200 40 022</b>
Repair kit 1 (motor side sealing, shaft sealing ring, coupling sleeves, compression spring)	<b>E 100 000 351</b>
Repair kit 2 (valves, oil demister, oil box seal)	<b>200 40 024</b>
Repair kit 3 (oil demister, sealing, wearing parts)	<b>E 100 000 347</b>

For further accessories see Chapter "Accessories for TRIVAC E, B and BCS"

# TRIVAC B, Two-Stage Rotary Vane Vacuum Pumps TRIVAC D 4 B to D 65 B



The TRIVAC B is part of the well-proven TRIVAC concept.

The TRIVAC B pumps with their comprehensive range of accessories have proven themselves time and again as rugged pumps in many and varied applications.

The inner body is assembled from individual parts without sealing components. The parts are pinned in order to ensure easy disassembly and reassembly of the parts.

All pumps from the D 4 B to the D 25 B model are equipped either with single-phase or three-phase motors. D 40 - 65 B models are equipped with three-phase motors. In the TRIVAC B, the pump unit and the motor are linked by an elastic coupling.

The TRIVAC B range is a modular system which divides into three groups:

TRIVAC 4/8 Series  
TRIVAC 16/25 Series  
TRIVAC 40/65 Series

### Advantages to the User

- All basic models (single-phase and three-phase motor) are certified in accordance with 2014/34/EU (ATEX) (Category 3 inside)
- High water vapor tolerance
- Continuous operation even at 1000 mbar with exhaust filter & oil return
- Built-in oil pump; pressure-lubricated sliding bearings
- All controls as well as the oil sight glass are located on the front face
- Either vertical or horizontal intake and exhaust ports
- Exchangeable inner body
- Anti-suckback valve controlled via the oil pressure
- Free of yellow metals
- Service-friendly
- Ideal as backing pump for medium and high vacuum applications, because of low oil backstreaming

### Typical Applications

See chapter "General, Applications and Accessories".

### Supplied Equipment

Small flanges, centering and clamping rings. The intake flange contains a dirt trap.

A carrying handle is standard for all pumps up to the D 25 B. TRIVAC B pumps with single-phase motors are delivered with ON/OFF switch, mains cord and main plug, ready for immediate operation.

Standard TRIVAC B pumps come with a filling of oil LEYBONOL  
All pumps are 100% subjected to a vacuum test before delivery!

### Custom Models

- ATEX (Category 3 inside and 3 outside)
- Brake fluid
- Oils for refrigerating machines, e.g. ester oils for refrigerant circuits with R 134 a
- Pressure burst resistant (for the new refrigerants propane and isobutane)

# TRIVAC D 16 B-DOT to D 40 B-DOT

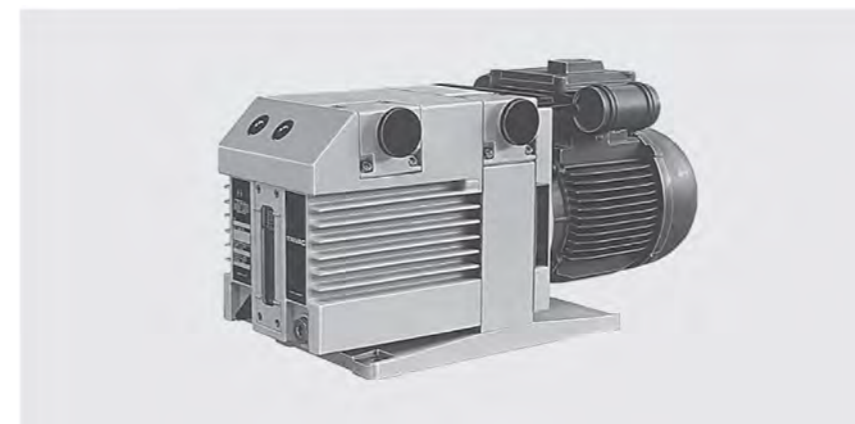

The TRIVAC B-DOT pumps operate with brake fluid (DOT 4) as the sealing and lubricating agent. Therefore these pumps are equipped with EPDM seals. EPDM is highly compatible with brake fluid.

### Advantages to the User

- Matching exhaust filters with EPDM gaskets (AF-DOT)
- Except for the seals and the fluid the TRIVAC B-DOT pumps are identical to the oil sealed TRIVAC B pumps

### Typical Applications

- For filling of brake fluid circuits in the automotive industry

### Supplied Equipment

- The brake fluid is inside the pump when shipped

# TRIVAC D 16 B-Ex, Explosion Protected and Pressure Burst Resistant



Vacuum pumps TRIVAC D 16 B-Ex meet the requirements of the European Directive 2014/34/EU (ATEX Directive). TRIVAC D 16 B-Ex pumps are classified inside as Category 1, outside as Category 2. Thus these pumps are suited for pumping explosive gases from Zone 0, the pump itself may be located in Zone 1.

The vacuum pumps TRIVAC D 16 B-Ex are qualified for gases of Explosion Groups IIC <sup>1)</sup> and IIB3. The temperature class is T4. TRIVAC D 16 B-Ex pumps are explosion resistant and correspond to the state-of-the-art. They are equipped as standard with one each temperature sensor on the intake and delivery side.

## ATEX Category 1 inside and 2 outside

### Typical Applications

- Pumping of gases belonging to Group IIB3 and IIC <sup>1)</sup> from Zone 0

Moreover, the pressure inside the pump is monitored. Flame arresters on the intake and delivery side protect the upstream and downstream system sections. Also provided as standard is an exhaust filter for every pump.

<sup>1)</sup> With the exception of acetylene and carbon bisulphide

# TRIVAC D 4 B and D 8 B



TRIVAC D 4 B (left) and TRIVAC D 8 B (right)

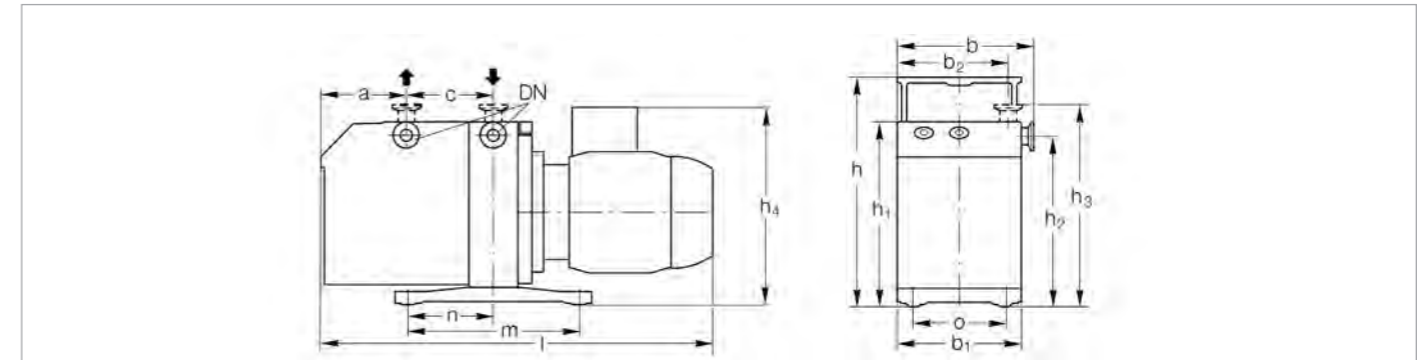

Type	DN		a	b	b <sub>1</sub>	b <sub>2</sub>	c	h	h <sub>1</sub>	h <sub>2</sub>	h <sub>3</sub>	h <sub>4</sub> <sup>1)</sup>	l <sup>1)</sup>	m	n	o
D 4 B (Part No. 112 45)	16 KF	mm	75	162	147	132	100	265	215	200	230	234	441	198	99	108
		in.	2.95	6.38	5.79	5.23	3.94	10.43	8.46	7.87	9.06	9.21	17.36	7.80	3.90	4.25
D 8 B (Part No. 112 55)	16 KF	mm	100	162	147	132	100	265	215	200	230	234	465	198	99	108
		in.	3.94	6.38	5.79	5.23	3.94	10.43	8.46	7.87	9.06	9.21	18.31	7.80	3.90	4.25

<sup>1)</sup> For dimensions h<sub>4</sub> and l for further part numbers, see paragraph "Motor Dependent Data for the TRIVAC B, BCS and BCS-PFPE"

Dimensional drawing for the TRIVAC D 4 B and D 8 B

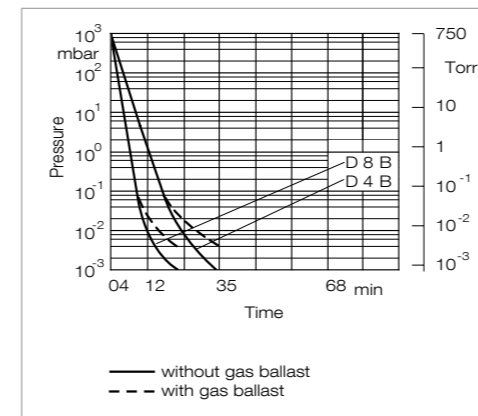

Pump-down characteristics of a 10 l vessel at 50 Hz

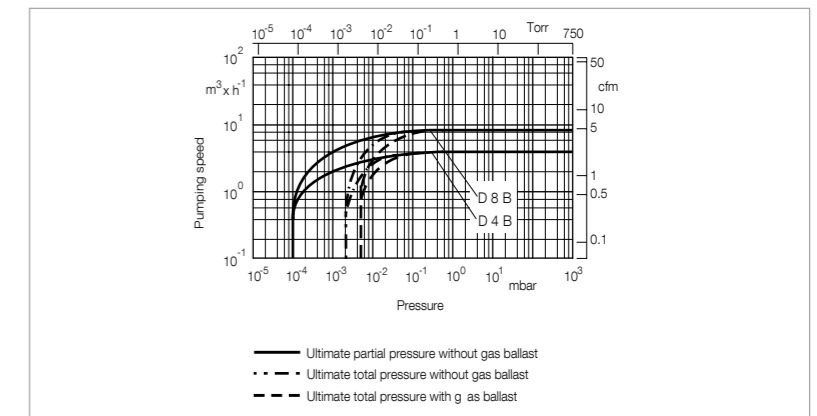

Pumping speed characteristics at 50 Hz (60 Hz curves at the end of the chapter)

## Technical Data

### TRIVAC D 4 B two-stage

### TRIVAC D 8 B two-stage

		50 Hz	60 Hz	50 Hz	60 Hz
Nominal pumping speed <sup>1)</sup>	m <sup>3</sup> /h (cfm)	4.8 (2.8)	5.8 (3.4)	9.7 (5.7)	11.6 (6.9)
Pumping speed <sup>1)</sup>	m <sup>3</sup> /h (cfm)	4.2 (2.5)	5.0 (3.0)	8.5 (5)	10.2 (6)
Ultimate partial pressure without gas ballast <sup>1)</sup>	mbar (Torr)	10 <sup>-4</sup> (0.75 x 10 <sup>-4</sup> )	10 <sup>-4</sup> (0.75 x 10 <sup>-4</sup> )	10 <sup>-4</sup> (0.75 x 10 <sup>-4</sup> )	10 <sup>-4</sup> (0.75 x 10 <sup>-4</sup> )
Ultimate total pressure without gas ballast <sup>1)</sup>	mbar (Torr)	≤ 2 x 10 <sup>-3</sup> (≤ 1.5 x 10 <sup>-3</sup> )	≤ 2 x 10 <sup>-3</sup> (≤ 1.5 x 10 <sup>-3</sup> )	≤ 2 x 10 <sup>-3</sup> (≤ 1.5 x 10 <sup>-3</sup> )	≤ 2 x 10 <sup>-3</sup> (≤ 1.5 x 10 <sup>-3</sup> )
Ultimate total pressure with gas ballast <sup>1)</sup>	mbar (Torr)	< 5 x 10 <sup>-3</sup> (< 3.8 x 10 <sup>-3</sup> )	< 5 x 10 <sup>-3</sup> (< 3.8 x 10 <sup>-3</sup> )	< 5 x 10 <sup>-3</sup> (< 3.8 x 10 <sup>-3</sup> )	< 5 x 10 <sup>-3</sup> (< 3.8 x 10 <sup>-3</sup> )
Water vapor tolerance <sup>1)</sup>	mbar (Torr)	30.0 (22.5)	30.0 (22.5)	25.0 (18.8)	25.0 (18.8)
Water vapor capacity	g/h (lbs/h)	93 (0.205)	110 (0.243)	160 (0.353)	190 (0.419)
Oil filling, min. / max.	l (qt)	0.3 / 0.8 (0.3 / 0.85)	0.3 / 0.8 (0.3 / 0.85)	0.3 / 0.9 (0.3 / 0.95)	0.3 / 0.9 (0.3 / 0.95)
Noise level <sup>2)</sup> to DIN 45 635, without / with gas ballast	dB(A)	50 / 52	50 / 52	50 / 52	50 / 52
Admissible ambient temperature	°C (°F)	+12 to +40 (+54 to +104)	+12 to +40 (+54 to +104)	+12 to +40 (+54 to +104)	+12 to +40 (+54 to +104)
Motor rating <sup>2)</sup>	W (HP)	370 (0.50)	370 (0.50)	370 (0.50)	370 (0.50)
Nominal speed	rpm	1500	1800	1500	1800
Type of protection	IP	3)	3)	3)	3)
Weight <sup>2)</sup>	kg (lbs)	18.7 (41.2)	18.7 (41.2)	21.2 (46.7)	21.2 (46.7)
Connections, Intake and Exhaust	DN	16 KF	16 KF	16 KF	16 KF

<sup>1)</sup> To DIN 28 400 and following numbers

<sup>2)</sup> Motor rating and noise levels for the pumps with AC motor 50 Hz.

Any data that deviate from the above for pumps with other motors, and other motor-dependent data are given in chapter "Products", paragraph "Motor Dependent Data for the TRIVAC B, BCS and BCS-PFPE".

<sup>3)</sup> See paragraph "Motor Dependent Data for the TRIVAC B, BCS and BCS-PFPE".

## Ordering Information

### TRIVAC D 4 B two-stage

### TRIVAC D 8 B two-stage

	Part No.	Part No.
TRIVAC B with 1-phase motor 230 V, 50 Hz <sup>1)</sup>	<b>112 45</b>	<b>112 55</b>
with dual voltage motor <sup>2)</sup> 110-115/210-230 V, 50/60 Hz	<b>140 081</b>	<b>140 082</b>
with 3-phase motor 200 – 240/380 – 400 V, 50 Hz / 200 – 240/380 – 480 V, 60 Hz <sup>1)</sup>	<b>112 46</b>	<b>112 56</b>
219 – 242 V / 380 – 420 V, 50Hz, ATEX Category 3 inside and 3 outside II 3/3G Ex h IIC T4 (50 Hz) Gc / EX h IIC T3 (50 Hz) Gc (12°C ≤ Ta ≤ 40°C)	<b>140 140</b>	<b>140 150</b>
Mains cord for dual voltage motor <sup>2)</sup> 230 V Schuko plug 230 V UK plug 230 V CH plug 230 V NEMA plug (200-240 V) 115 V NEMA plug (100-120 V)	<b>E20081091</b> <b>E20081097</b> <b>E20081099</b> <b>E20081141</b> <b>E20081090</b>	<b>E20081091</b> <b>E20081097</b> <b>E20081099</b> <b>E20081141</b> <b>E20081090</b>
Transition connector (250 V AC, 10 A, L+N+PE) only necessary in Switzerland for 1~ pumps	<b>800 001 274</b>	<b>800 001 274</b>
<b>Accessories</b>		
Dust filter Filter pot FH 16 Dust filter insert DF 16-25	<b>140 116 T</b> <b>140 117 T</b>	<b>140 116 T</b> <b>140 117 T</b>
Adsorption trap Filter pot FH 16 Dust filter insert DF 16-25	<b>140 116 T</b> <b>140 118 A</b>	<b>140 116 T</b> <b>140 118 A</b>
Accessories for dust filter and adsorption trap Active charcoal Zeolite Activated aluminium oxide, 1.3 kg (2 l approx.)	<b>178 10</b> <b>854 20</b> <b>854 10</b>	<b>178 10</b> <b>854 20</b> <b>854 10</b>
TK 4-8 cold trap	<b>188 20</b>	<b>188 20</b>
AF 4-8 exhaust filter	<b>189 06</b>	<b>189 06</b>
AR 4-8 exhaust filter with lubricant return	<b>189 20</b>	<b>189 20</b>
AK 4-8 condensate trap	<b>188 06</b>	<b>188 06</b>
OF 4-25 mechanical oil filter	<b>101 91</b>	<b>101 91</b>
CF 4-25 chemical oil filter	<b>101 96</b>	<b>101 96</b>
Connector for gas ballast inlet M 16 x 1.5 – DN 16 KF	<b>168 40V01</b>	<b>168 40V01</b>
Oil drain tap M 16 x 1.5	<b>190 90</b>	<b>190 90</b>
<b>Spare Parts</b>		
Inner body	<b>E 200 10 989</b>	<b>E 200 10 991</b>
Major maintenance kit (without oil)	<b>EK 110 002 622</b>	<b>EK 110 002 620</b>
Minor maintenance kit (without oil)	<b>EK 110 002 628</b>	<b>EK 110 002 627</b>
Shaft sealing replacement kit	<b>EK 110 002 631</b>	<b>EK 110 002 631</b>
Small parts kit	<b>EK 110 002 634</b>	<b>EK 110 002 634</b>
Seal kit	<b>197 20</b>	<b>197 20</b>

For further accessories see section "Accessories for TRIVAC E, B and BCS"

<sup>1)</sup> Certification after 2014/34/EU (ATEX), Category 3 inside. II 3/-G Ex h IIC T4 (50 Hz) Gc, II 3/-G Ex h IIC T3 (60 Hz) Gc, (12°C ≤ Ta ≤ 40°C)

<sup>2)</sup> Mains cord 20081091 (Schuko) in delivery included. Other mains cords must be ordered additionally.

# TRIVAC D 16 B and D 25 B



TRIVAC D 16 B (left) and TRIVAC D 25 B (right)

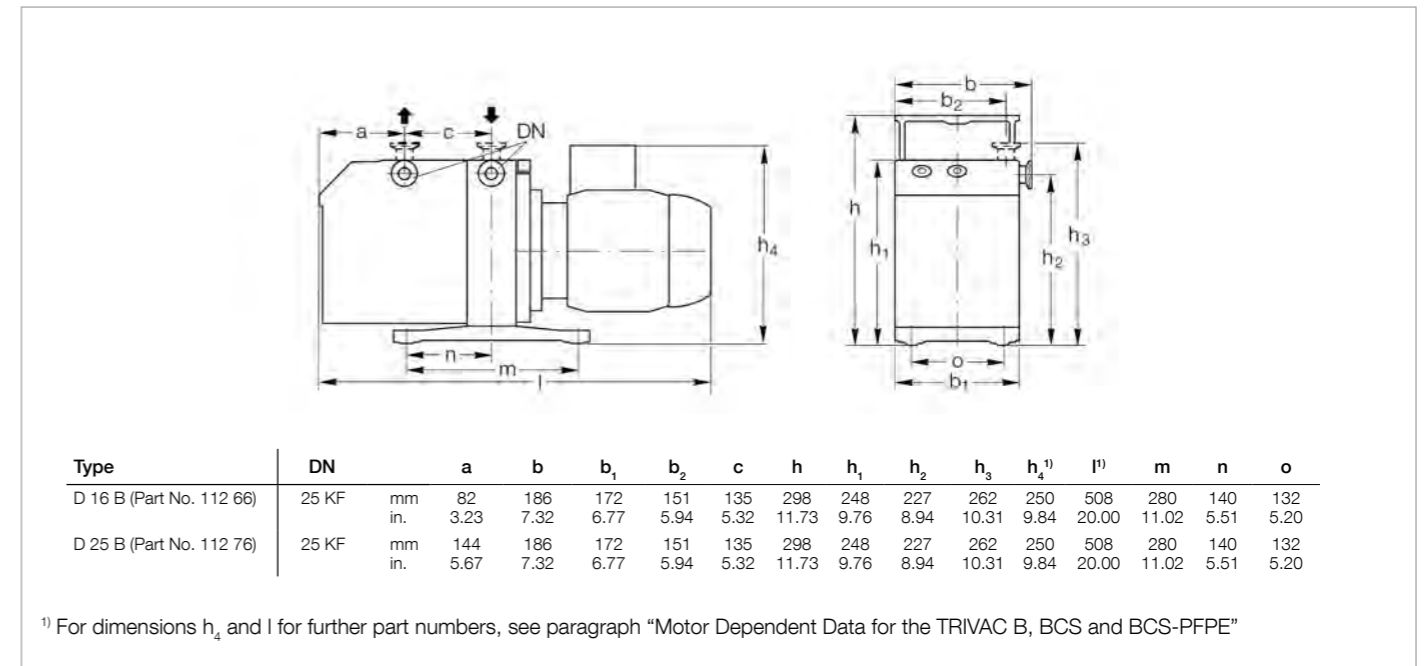

Dimensional drawing for the TRIVAC D 16 and D 25 B

**Technical Data**

**TRIVAC D 16 B**  
two-stage

**TRIVAC D 25 B**  
two-stage

		50 Hz	60 Hz	50 Hz	60 Hz
Nominal pumping speed <sup>1)</sup>	m <sup>3</sup> /h (cfm)	18.9 (11.1)	22.7(13.4)	29.5 (17.4)	35.4 (20.9)
Pumping speed <sup>1)</sup>	m <sup>3</sup> /h (cfm)	16.5 (9.7)	19.8 (11.7)	25.7 (15.1)	30.8 (18.2)
Ultimate partial pressure without gas ballast <sup>1)</sup>	mbar (Torr)	10 <sup>-4</sup> (0.75 x 10 <sup>-4</sup> )	10 <sup>-4</sup> (0.75 x 10 <sup>-4</sup> )	10 <sup>-4</sup> (0.75 x 10 <sup>-4</sup> )	10 <sup>-4</sup> (0.75 x 10 <sup>-4</sup> )
Ultimate total pressure without gas ballast <sup>1)</sup>	mbar (Torr)	≤ 2 x 10 <sup>-3</sup> (≤ 1.5 x 10 <sup>-3</sup> )	≤ 2 x 10 <sup>-3</sup> (≤ 1.5 x 10 <sup>-3</sup> )	≤ 2 x 10 <sup>-3</sup> (≤ 1.5 x 10 <sup>-3</sup> )	≤ 2 x 10 <sup>-3</sup> (≤ 1.5 x 10 <sup>-3</sup> )
Ultimate total pressure with gas ballast <sup>1)</sup>	mbar (Torr)	< 5 x 10 <sup>-3</sup> (< 3.8 x 10 <sup>-3</sup> )	< 5 x 10 <sup>-3</sup> (< 3.8 x 10 <sup>-3</sup> )	< 5 x 10 <sup>-3</sup> (< 3.8 x 10 <sup>-3</sup> )	< 5 x 10 <sup>-3</sup> (< 3.8 x 10 <sup>-3</sup> )
Water vapor tolerance <sup>1)</sup>	mbar (Torr)	25.0 (18.8)	25.0 (18.8)	25.0 (18.8)	25.0 (18.8)
Water vapor capacity	g/h (lbs/h)	305 (0.672)	370 (0.816)	476 (1.049)	570 (1.257)
Oil filling, min. / max.	l (qt)	0.5 / 1.0 (0.5 / 1.1)	0.5 / 1.0 (0.5 / 1.1)	0.6 / 1.4 (0.6 / 1.5)	0.6 / 1.4 (0.6 / 1.5)
Noise level <sup>2)</sup> to DIN 45 635, without / with gas ballast	dB(A)	54 / 56	54 / 56	54 / 56	54 / 56
Admissible ambient temperature	°C (°F)	+12 to +40 (+54 to +104)	+12 to +40 (+54 to +104)	+12 to +40 (+54 to +104)	+12 to +40 (+54 to +104)
Motor rating <sup>2)</sup>	W (HP)	750 (1)	750 (1)	750 (1)	750 (1)
Nominal speed	rpm	1425	1730	1425	1730
Type of protection	IP	<sup>3)</sup>	<sup>3)</sup>	<sup>3)</sup>	<sup>3)</sup>
Weight <sup>2)</sup>	kg (lbs)	28 (61.7)	28 (61.7)	32.3 (71.2)	32.3 (71.2)
Connections, Intake and Exhaust	DN	25 KF	16 KF	16 KF	16 KF

<sup>1)</sup> To DIN 28 400 and following numbers

<sup>2)</sup> Motor rating and noise levels for the pumps with AC motor 50 Hz. Any data that deviate from the above for pumps with other motors, and other motor-dependent data are given in chapter "Products", paragraph "Motor Dependent Data for the TRIVAC B, BCS and BCS-PFPE".

<sup>3)</sup> See paragraph "Motor Dependent Data for the TRIVAC B, BCS and BCS-PFPE".

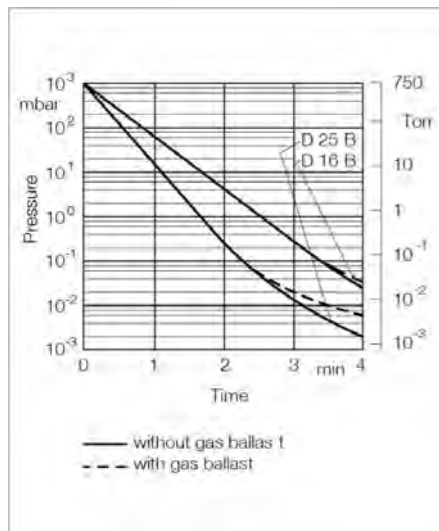

Pump-down characteristics of a 100 l vessel at 50 Hz

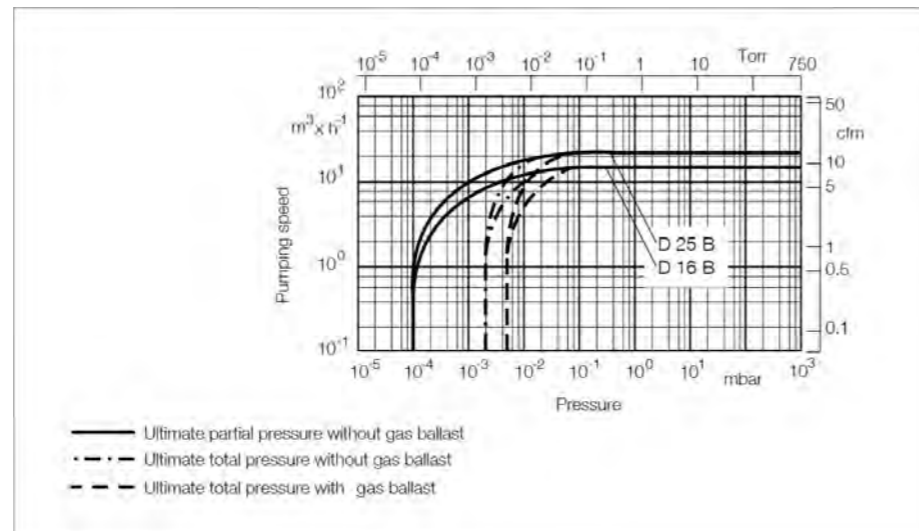

Pumping speed characteristics at 50 Hz (60 Hz curves at the end of the chapter)

**Ordering Information**

**TRIVAC D 16 B**  
two-stage

**TRIVAC D 25 B**  
two-stage

	Part No.	Part No.
TRIVAC B with 1-phase motor 218 – 242 V, 50/60 Hz <sup>1)</sup> 208 – 252 V, 50/60 Hz <sup>1)</sup> 110/220 V, 50 Hz / 115/208 – 230 V, 60 Hz <sup>3)</sup>	<b>112 65</b> <b>113 25 <sup>2)</sup></b> <b>898 698</b>	<b>112 75</b> <b>113 35 <sup>2)</sup></b> –
with 3-phase motor 200 – 240 V (200 V IE3) / 380 – 400 V (380 – 400 V IE3), 50 Hz / 200 – 240 (208 – 240 V IE3) / 380 – 480 V (416 – 480 V IE3), 60 Hz <sup>1)</sup>	<b>112 66</b> <b>113 33 (LVO 210)</b>	<b>112 76</b>
219 – 242 / 380 – 420 V, 50 Hz, ATEX Category 3 inside and 3 outside II 3/3G Ex h IIC T4 (50 Hz) Gc / EX h IIC T3 (50 Hz) Gc (12°C ≤ Ta ≤ 40°C)	<b>140 160</b>	<b>140 170</b>
<b>Accessories</b>		
Mains cord for Part No. 898 698 115 V 230 V	<b>E 721 27 874</b> <b>E 721 27 875</b>	– –
Dust filter Filter pot FH 16 Dust filter insert DF 16-25	<b>140 125 T</b> <b>140 117 S</b>	<b>140 125 T</b> <b>140 117 S</b>
Adsorption trap Filter pot FH 25 Adsorption filter insert RF 16-25	<b>140 125 T</b> <b>140 118 A</b>	<b>140 125 T</b> <b>140 118 A</b>
Accessories for dust filter and adsorption trap Active charcoal Zeolite Activated aluminium oxide, 1.3 kg (2 l approx.)	<b>178 10</b> <b>854 20</b> <b>854 10</b>	<b>178 10</b> <b>854 20</b> <b>854 10</b>
AF 16-25 exhaust filter	<b>189 11</b>	<b>189 11</b>
AR 16-25 exhaust filter with lubricant return	<b>189 21</b>	<b>189 21</b>
AK 16-25 condensate trap	<b>188 11</b>	<b>188 11</b>
OF 4-25 mechanical oil filter	<b>101 91</b>	<b>101 91</b>
CF 4-25 chemical oil filter	<b>101 96</b>	<b>101 96</b>
Connector for gas ballast inlet M 16 x 1.5 – DN 16 KF	<b>168 40V01</b>	<b>168 40V01</b>
Oil drain tap M 16 x 1.5	<b>190 90</b>	<b>190 90</b>
<b>Spare Parts</b>		
Inner body	<b>E 200 10 956</b>	<b>E 200 10 960</b>
Major maintenance kit (without oil)	<b>EK 110 002 618</b>	<b>EK 110 002 616</b>
Minor maintenance kit (without oil)	<b>EK 110 002 626</b>	<b>EK 110 002 625</b>
Shaft sealing replacement kit	<b>EK 110 002 630</b>	<b>EK 110 002 630</b>
Small parts kit	<b>EK 110 002 635</b>	<b>EK 110 002 635</b>
Seal kit	<b>197 21</b>	<b>197 21</b>

For further accessories see section "Accessories for TRIVAC E, B and BCS"

<sup>1)</sup> Certification after 2014/34/EU (ATEX), Category 3 inside. II 3/-G Ex h IIC T4 (50 Hz) Gc, II 3/-G Ex h IIC T3 (60 Hz) Gc, (12°C ≤ Ta ≤ 40°C)

<sup>2)</sup> With cable EURO Schuko. Other cables for wide range motor upon request.

<sup>3)</sup> Mains cord for dual voltage motor see paragraph "Motor Dependent Data for the TRIVAC B, BCS and BCS-PFPE"; TRIVAC D 16 B / D 25 B

# TRIVAC D 40 B and D 65 B



TRIVAC D 40 B (left) and TRIVAC D 65 B (right)

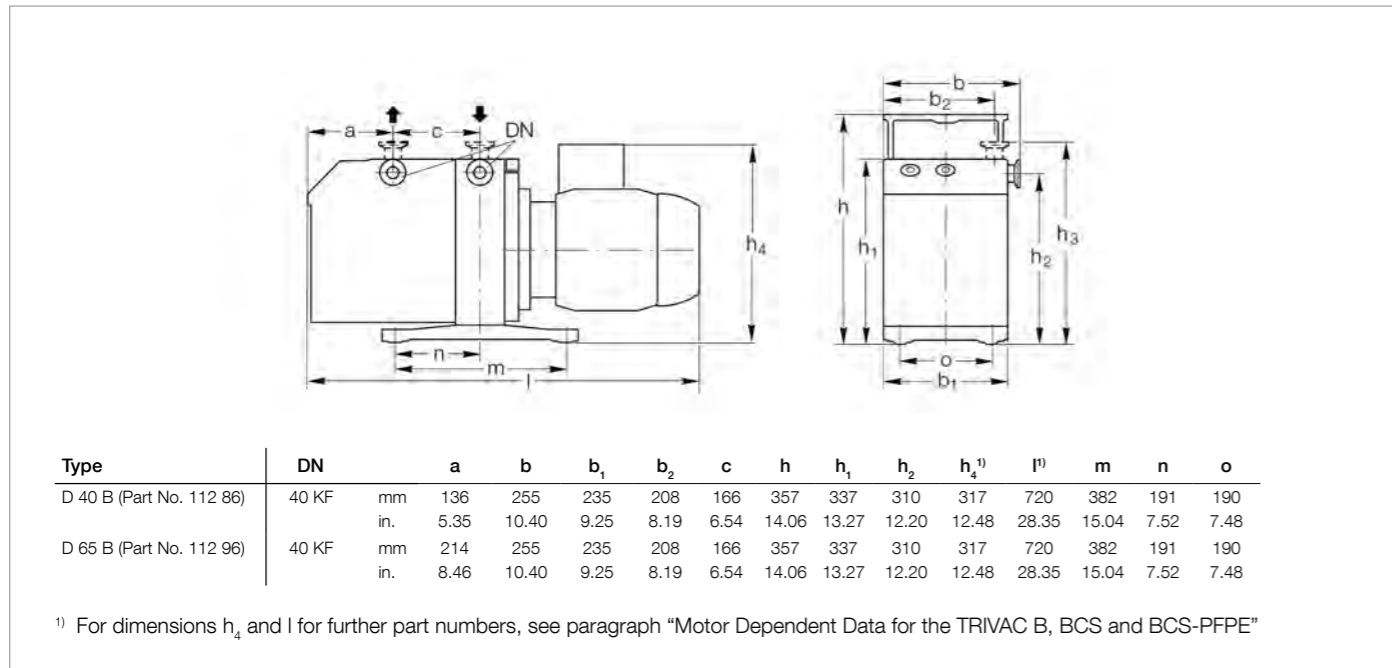

Dimensional drawing for the TRIVAC D 40 and D 65 B

## Technical Data

		TRIVAC D 40 B two-stage		TRIVAC D 65 B two-stage	
		50 Hz	60 Hz	50 Hz	60 Hz
Nominal pumping speed <sup>1)</sup>	m <sup>3</sup> /h (cfm)	46 (27)	55 (32.5)	75 (44)	90 (53)
Pumping speed <sup>1)</sup>	m <sup>3</sup> /h (cfm)	40 (24)	48 (28)	65 (38)	78 (46)
Ultimate partial pressure without gas ballast <sup>1)</sup>	mbar (Torr)	10 <sup>-4</sup> (0.75 x 10 <sup>-4</sup> )	10 <sup>-4</sup> (0.75 x 10 <sup>-4</sup> )	10 <sup>-4</sup> (0.75 x 10 <sup>-4</sup> )	10 <sup>-4</sup> (0.75 x 10 <sup>-4</sup> )
Ultimate total pressure without gas ballast <sup>1)</sup>	mbar (Torr)	≤ 2 x 10 <sup>-3</sup> (≤ 1.5 x 10 <sup>-3</sup> )	≤ 2 x 10 <sup>-3</sup> (≤ 1.5 x 10 <sup>-3</sup> )	≤ 2 x 10 <sup>-3</sup> (≤ 1.5 x 10 <sup>-3</sup> )	≤ 2 x 10 <sup>-3</sup> (≤ 1.5 x 10 <sup>-3</sup> )
Ultimate total pressure with gas ballast <sup>1)</sup>	mbar (Torr)	< 5 x 10 <sup>-3</sup> (< 3.8 x 10 <sup>-3</sup> )	< 5 x 10 <sup>-3</sup> (< 3.8 x 10 <sup>-3</sup> )	< 5 x 10 <sup>-3</sup> (< 3.8 x 10 <sup>-3</sup> )	< 5 x 10 <sup>-3</sup> (< 3.8 x 10 <sup>-3</sup> )
Water vapor tolerance <sup>1)</sup>	mbar (Torr)	40 (30)	40 (30)	40 (30)	40 (30)
Water vapor capacity	g/h (lbs/h)	1184 (2.610)	1420 (3.131)	1925 (4.244)	2310 (5.093)
Oil filling, min. / max.	l (qt)	1.7 / 2.6 (1.8 / 2.7)	1.7 / 2.6 (1.8 / 2.7)	2.0 / 3.3 (2.1 / 3.5)	2.0 / 3.3 (2.1 / 3.5)
Noise level <sup>2)</sup> to DIN 45 635, without / with gas ballast	dB(A)	57 / 59	57 / 59	57 / 59	57 / 59
Admissible ambient tem- perature	°C (°F)	+12 to +40 (+54 to +104)	+12 to +40 (+54 to +104)	+12 to +40 (+54 to +104)	+12 to +40 (+54 to +104)
Motor rating <sup>2)</sup>	W (HP)	2200 (3.0)	2200 (3.0)	2200 (3.0)	2200 (3.0)
Nominal speed	rpm	1460	1760	1460	1760
Type of protection	IP	3)	3)	3)	3)
Weight <sup>2)</sup>	kg (lbs)	75.3 (166)	75.3 (166)	84.5 (186.3)	84.5 (186.3)
Connections, Intake and Exhaust	DN	40 KF	40 KF	40 KF	40 KF

<sup>1)</sup> To DIN 28 400 and following numbers

<sup>2)</sup> Motor rating and noise levels for the pumps with AC motor 50 Hz.

Any data that deviate from the above for pumps with other motors, and other motor-dependent data are given in chapter "Products", paragraph "Motor Dependent Data for the TRIVAC B, BCS and BCS-PFPE".

<sup>3)</sup> See paragraph "Motor Dependent Data for the TRIVAC B, BCS and BCS-PFPE".

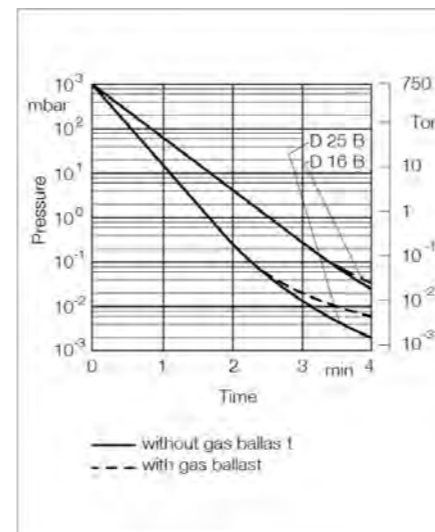

Pump-down characteristics of a 100 l vessel at 50 Hz

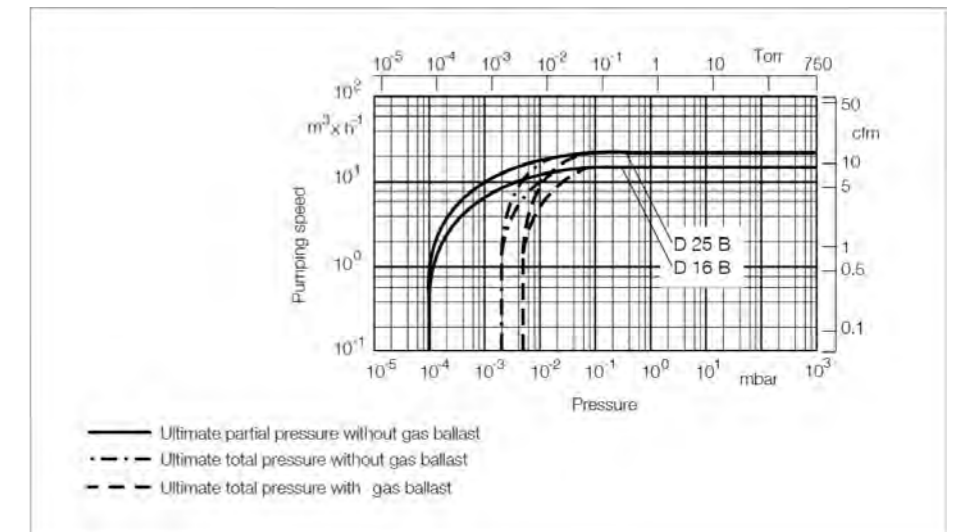

Pumping speed characteristics at 50 Hz (60 Hz curves at the end of the chapter)



# TRIVAC D 16 B-DOT to D 40 B-DOT

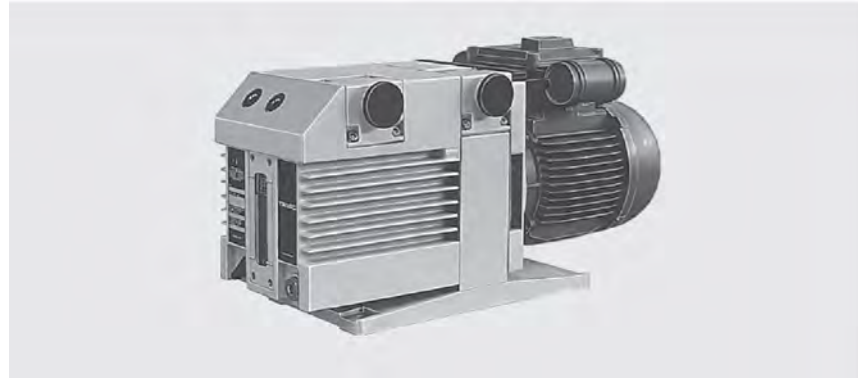

TRIVAC D 16 B-DOT

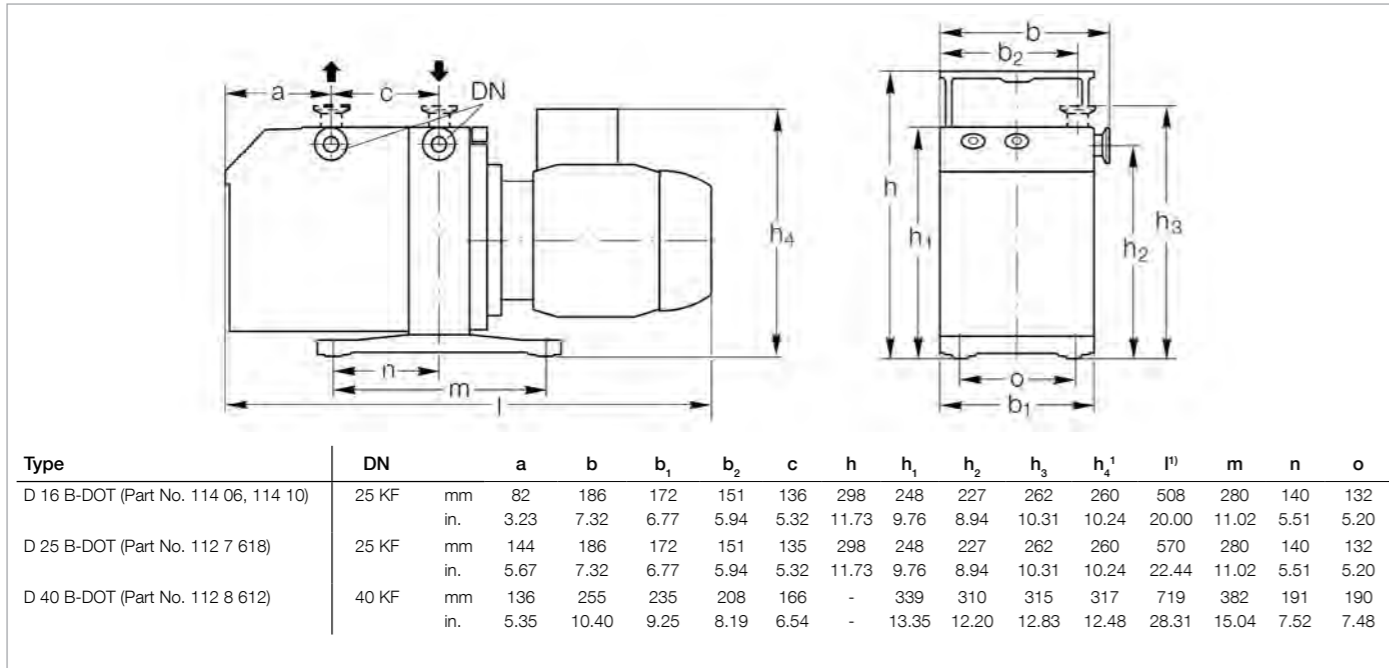

Dimensional drawing for the TRIVAC D B-DOT pumps

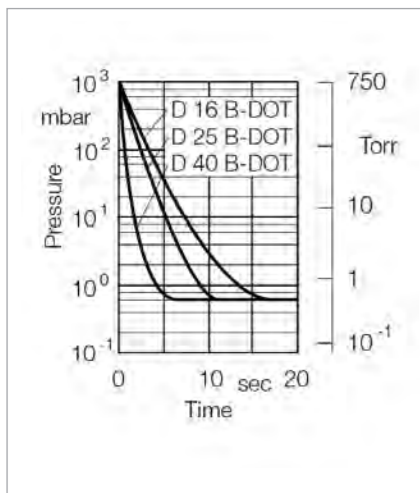

Pump-down characteristics of a 10 l vessel at 50 Hz

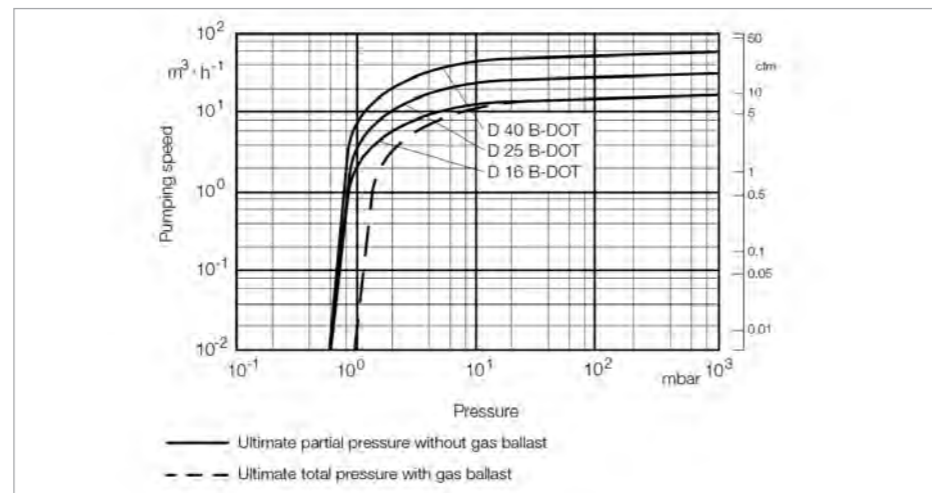

Pumping speed characteristics at 50 Hz (60 Hz curves at the end of the chapter)

## Technical Data

## TRIVAC D 16 B-DOT two-stage

		50 Hz	60 Hz
Nominal pumping speed <sup>1)</sup>	m <sup>3</sup> /h (cfm)	18.9 (11.1)	22.7 (13.4)
Pumping speed <sup>1)</sup>	m <sup>3</sup> /h (cfm)	16.5 (9.7)	19.8 (11.7)
Ultimate total pressure without gas ballast <sup>1)</sup>	mbar (Torr)	< 6 x 10 <sup>-1</sup> (< 4.5 x 10 <sup>-1</sup> )	< 6 x 10 <sup>-1</sup> (< 4.5 x 10 <sup>-1</sup> )
Ultimate total pressure without gas ballast <sup>1)</sup>	mbar (Torr)	< 9 x 10 <sup>-1</sup> (< 6.75 x 10 <sup>-1</sup> )	< 9 x 10 <sup>-1</sup> (< 6.75 x 10 <sup>-1</sup> )
Water vapor tolerance <sup>1)</sup>	mbar (Torr)	25.0 (18.8)	25.0 (18.8)
Water vapor capacity	g/h (lbs/h)	305 (0.672)	370 (0.816)
Brake fluid filling, min. / max.	l (qt)	0.45 / 1.0 (0.5 / 1.1)	0.45 / 1.0 (0.5 / 1.1)
Noise level <sup>2)</sup> to DIN 45 635, without / with gas ballast	dB(A)	54 / 56	54 / 56
Admissible ambient temperature	°C (°F)	+12 to +40 (+54 to +104)	+12 to +40 (+54 to +104)
Motor rating	W (HP)	750 (1)	750 (1)
Nominal speed	rpm	1460	1730
Type of protection	IP	<sup>2)</sup>	<sup>2)</sup>
Weight <sup>2)</sup>	kg (lbs)	28.2 (62.2)	28.2 (62.2)
Connections, Intake and Exhaust	DN	25 KF	25 KF

<sup>1)</sup> To DIN 28 400 and following numbers

<sup>2)</sup> See paragraph "Motor Dependent Data for the TRIVAC B, BCS and BCS-PFPE".

## Ordering Information

## TRIVAC D 16 B-DOT two-stage

	Part No.
TRIVAC B-DOT with 3-phase motor 200 – 240 V (200 V IE3) / 380 – 400 V (380 – 400 V IE3), 50 Hz / 200 – 240 V (208 – 240 V IE3) / 400 – 480 V (416 – 480 V IE3), 60 Hz	<b>114 06</b> <b>114 10 (with limit switch system LSS 16-25)</b>
AF 16-25 DOT exhaust filter	<b>124 16</b>
AK DOT condensate trap	<b>110 78</b>
Major maintenance kit 16 DOT (without oil)	<b>EK110002100</b>

**Technical Data**

**TRIVAC D 25 B-DOT  
two-stage**

		<b>50 Hz</b>	<b>60 Hz</b>
Nominal pumping speed <sup>1)</sup>	m <sup>3</sup> /h (cfm)	29.5 (17.4)	35.4 (20.9)
Pumping speed <sup>1)</sup>	m <sup>3</sup> /h (cfm)	25.7 (17.4)	30.8 (18.2)
Ultimate total pressure without gas ballast <sup>1)</sup>	mbar (Torr)	< 6 x 10 <sup>-1</sup> (< 4.5 x 10 <sup>-1</sup> )	< 6 x 10 <sup>-1</sup> (< 4.5 x 10 <sup>-1</sup> )
Ultimate total pressure with gas ballast <sup>1)</sup>	mbar (Torr)	< 9 x 10 <sup>-1</sup> (< 6.75 x 10 <sup>-1</sup> )	< 9 x 10 <sup>-1</sup> (< 6.75 x 10 <sup>-1</sup> )
Water vapor tolerance <sup>1)</sup>	mbar (Torr)	25.0 (18.8)	25.0 (18.8)
Water vapor capacity	g/h (lbs/h)	476 (1.049)	570 (1.257)
Brake fluid filling, min. / max.	l (qt)	0.6 / 1.4 (6.3 / 1.5)	0.6 / 1.4 (6.3 / 1.5)
Noise level <sup>2)</sup> to DIN 45 635, without / with gas ballast	dB(A)	54 / 56	54 / 56
Admissible ambient temperature	°C (°F)	+12 to +40 (+54 to +104)	+12 to +40 (+54 to +104)
Motor rating	W (HP)	750 (1)	750 (1)
Nominal speed	rpm	1425	1730
Type of protection	IP	<sup>2)</sup>	<sup>2)</sup>
Weight <sup>2)</sup>	kg (lbs)	32.5 (71.7)	32.5 (71.7))
Connections, Intake and Exhaust	DN	25 KF	25 KF

<sup>1)</sup> To DIN 28 400 and following numbers

<sup>2)</sup> See paragraph "Motor Dependent Data for the TRIVAC B, BCS and BCS-PFPE".

**Ordering Information**

**TRIVAC D 16 B-DOT  
two-stage**

	<b>Part No.</b>
TRIVAC B-DOT with 3-phase motor 200 – 240 V (200 V IE3) / 380 – 400 V (380 – 400 V IE3), 50 Hz / 200 – 240 (208 – 240 V IE3) / 400 – 480 V (416 – 480 V IE3), 60 Hz	<b>112 76 18</b>
AF 16-25 DOT exhaust filter	<b>124 16</b>
AK DOT condensate trap	<b>110 78</b>
Major maintenance kit 25 DOT (without oil)	<b>EK110002101</b>

**Technical Data**

**TRIVAC D 40 B-DOT  
two-stage**

		<b>50 Hz</b>	<b>60 Hz</b>
Nominal pumping speed <sup>1)</sup>	m <sup>3</sup> /h (cfm)	46.0 (27.0)	55.0 (32.5)
Pumping speed <sup>1)</sup>	m <sup>3</sup> /h (cfm)	40.0 (24.0)	48.0 (28.0)
Ultimate total pressure without gas ballast <sup>1)</sup>	mbar (Torr)	< 6 x 10 <sup>-1</sup> (< 4.5 x 10 <sup>-1</sup> )	< 6 x 10 <sup>-1</sup> (< 4.5 x 10 <sup>-1</sup> )
Ultimate total pressure with gas ballast <sup>1)</sup>	mbar (Torr)	< 9 x 10 <sup>-1</sup> (< 6.75 x 10 <sup>-1</sup> )	< 9 x 10 <sup>-1</sup> (< 6.75 x 10 <sup>-1</sup> )
Water vapor tolerance <sup>1)</sup>	mbar (Torr)	40 (30)	40 (30)
Water vapor capacity	g/h (lbs/h)	1184 (2.610)	1420 (3.130)
Brake fluid filling, min. / max.	l (qt)	1.7 / 2.6 (1.8 / 2.7)	1.7 / 2.6 (1.8 / 2.7)
Noise level <sup>2)</sup> to DIN 45 635, without / with gas ballast	dB(A)	57 / 59	57 / 59
Admissible ambient temperature	°C (°F)	+12 to +40 (+54 to +104)	+12 to +40 (+54 to +104)
Motor rating	W (HP)	2200 (3.0)	2200 (3.0)
Nominal speed	rpm	1460	1730
Type of protection	IP	<sup>2)</sup>	<sup>2)</sup>
Weight <sup>2)</sup>	kg (lbs)	75.8 (167)	75.8 (167)
Connections, Intake and Exhaust	DN	40 KF	40 KF

<sup>1)</sup> To DIN 28 400 and following numbers

<sup>2)</sup> See paragraph "Motor Dependent Data for the TRIVAC B, BCS and BCS-PFPE".

**Ordering Information**

**TRIVAC D 40 B-DOT  
two-stage**

	<b>Part No.</b>
TRIVAC B-DOT with 3-phase motor 200 – 240 V (200 V IE3) / 380 – 400 V (380 – 400 V IE3), 50 Hz / 200 – 240 (208 – 240 V IE3) / 400 – 480 V (416 – 480 V IE3), 60 Hz	<b>112 86 12</b>
AF 40 DOT exhaust filter	<b>101 15</b>
AK DOT condensate trap	<b>upon request</b>
Major maintenance kit 40 DOT (without oil)	<b>EK110002102</b>

# TRIVAC D 16 B-Ex (Explosion Protected and Pressure Burst Resistant)



TRIVAC D 16 B-Ex

## ATEX

Category 1 inside and 2 outside

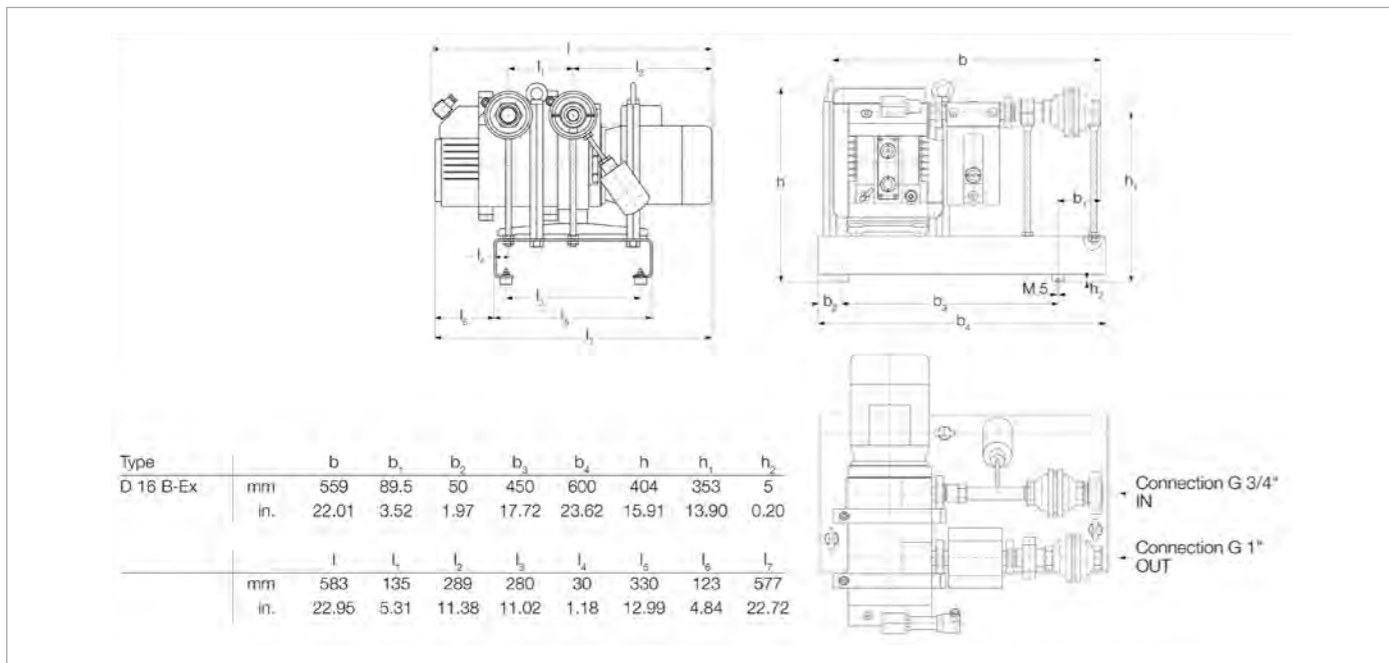

Dimensional drawing for the TRIVAC D 16 B-Ex (explosion protected and pressure burst resistant)

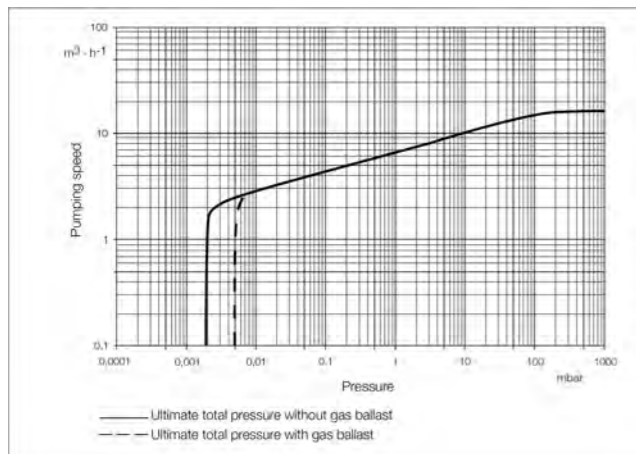

Pumping speed characteristics of TRIVAC D 16 B-Ex (IIB3 T4) (Part No. 140 091)

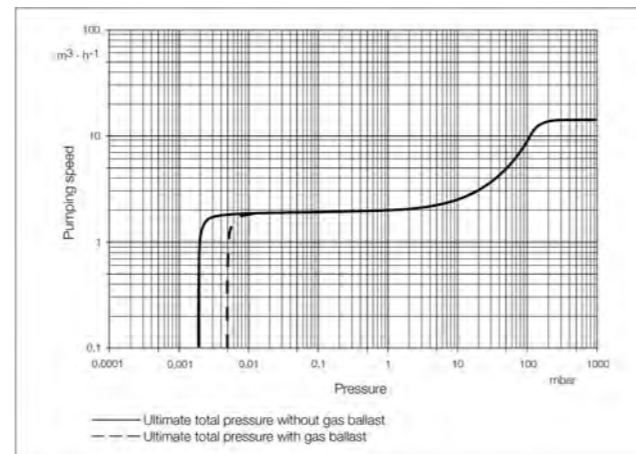

Pumping speed characteristics of TRIVAC D 16 B-Ex (IIC T4) (Part No. 140 092)

### Technical Data

### TRIVAC D 16 B-Ex (Explosion Protected and Pressure Burst Resistant) Two-Stage

Nominal pumping speed	m <sup>3</sup> /h (cfm)	18.9 (11.1)
Pumping speed (for Part No. 140 091 / 140 092) <sup>1)</sup>	m <sup>3</sup> /h (cfm)	16 / 15 (9.4/8.8)
Ultimate partial pressure without gas ballast <sup>1)</sup>	mbar (Torr)	1 x 10 <sup>-4</sup> (< 0.75 x 10 <sup>-3</sup> )
Ultimate total pressure with gas ballast <sup>1)</sup>	mbar (Torr)	< 5 x 10 <sup>-3</sup> (< 3.8 x 10 <sup>-3</sup> )
Water vapor tolerance <sup>1)</sup>	mbar (Torr)	25 (18.8)
Water vapor capacity	g/h (lbs/h)	240 (0.529)
Oil filling, min. / max.	l (qt)	0.55 / 1.3 (0.58 / 1.4)
Motor		3~, 230 V / 400 V, 50 Hz, Ex e II T4
Type of protection	IP	55
Maximum gas inlet temperature	°C (°F)	60 (140)
Highest permissible pressure in the oil box	mbar (Torr)	1500 (1125)
Ambient temperature (t <sub>a</sub> )	°C (°F)	+12 to +40 (+46 to +104)
Maximum surface temperature	°C (°F)	135 (275)
Max. Inlet pressure	mbar (Torr)	Atmospheric pressure
Weight (complete system)	kg (lbs)	72 (159)
Materials (materials in contact with the gas)		Steel, hardened steel, spring steel, stainless steel, zinc, aluminium and aluminium alloys, grey cast iron 25, FKM, felt, glass, silicone, polyamide
Connections		
Intake side	Inside thread	G 3/4"
Pressure side	Inside thread	G 1"

### Ordering Information

### TRIVAC D 16 B-Ex (Explosion Protected and Pressure Burst Resistant) Two-Stage

	Part No.
TRIVAC D 16 B-Ex IIB3 T4 in accordance with 214/34/EU [Ex II 1/2G Ex h IIB3 T4 Ga / Ex h IIC T4 Gb (12°C ≤ T <sub>a</sub> ≤ 40°C) EC Type Examination Certificate: IBExU03ATEX1017 X]	140 091
TRIVAC D 16 B-Ex IIC T4 <sup>2)</sup> in accordance with 214/34/EU [Ex II 1/2G Ex h IIC (no C <sub>2</sub> H <sub>2</sub> , CS <sub>2</sub> ) T4 Ga / Ex h IIC T4 Gb (12°C ≤ T <sub>a</sub> ≤ 40°C) EC Type Examination Certificate: IBExU03ATEX1016 X]	140 092 <sup>2)</sup>

<sup>1)</sup> To DIN 28 400 and following numbers

<sup>2)</sup> with the exception of acetylene and carbon bisulphide

For all enquiries and orders relating to category 1 and 2 ATEX products please exclusively use our ATEX questionnaire. You can find this questionnaire at the end of the full-line catalog together with the fax forms or on the Internet under "www.leybold.com" under Downloads in the area Media.

# TRIVAC BCS, Two-Stage Rotary Vane Vacuum Pumps

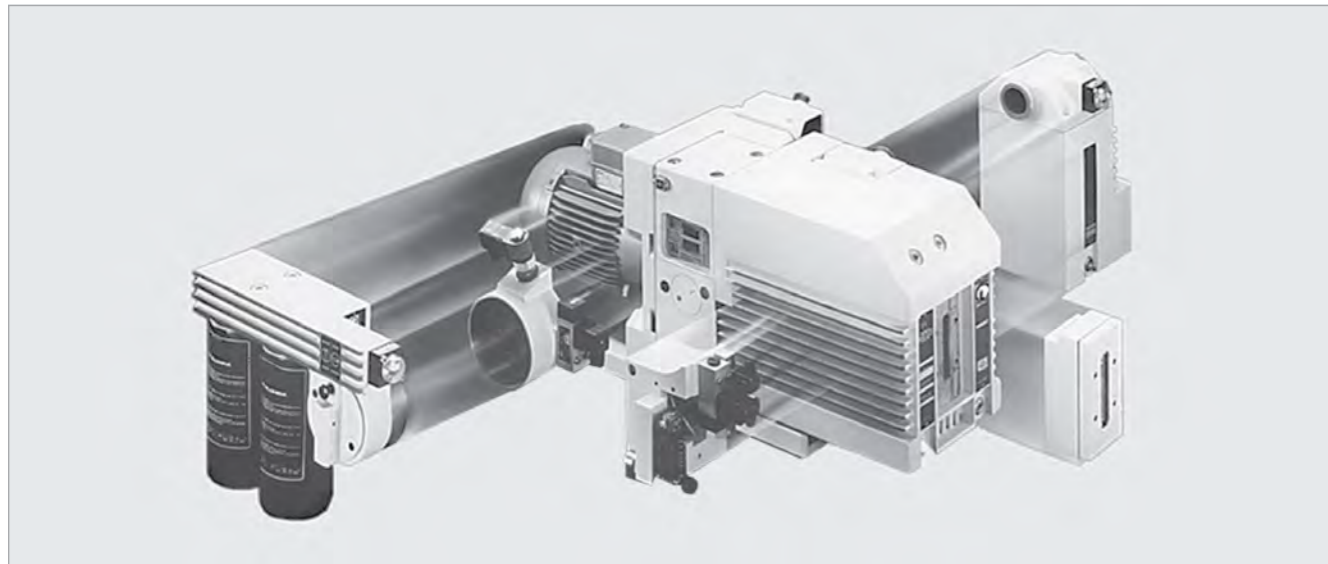

TRIVAC System

The TRIVAC BCS pumps are oil sealed vacuum pumps operating according to the rotary vane principle. Oil which is injected into the pump chamber is used for sealing, lubrication and cooling purposes.

The pump body is assembled from individual parts without sealing components. The parts are pinned in order to ensure easy disassembly and reassembly of the parts.

The motor is connected to the pumping section via an elastic coupling.

In addition, the TRIVAC BCS is ready for system integration (adaptable to different applications).

### Advantages to the User

- Compact design
- Low noise operation with hardly any vibrations
- Built-in oil pump
- Continuous operation even at 1000 mbar (750 Torr)
- Pressure-lubricated sliding bearings

- Anti-suckback valve controlled via the oil pressure, no backstreaming of oil, independent of the operating mode, with or without gas ballast
- Low backstreaming of oil within the pump
- High pumping speed down to ultimate pressure
- Either vertical or horizontal intake and exhaust ports
- All controls as well as the oil sight glass are located on the face side
- Low power consumption
- Produces very little heat
- Exchangeable inner section
- Main flow oil filters may be fitted
- Very long service life
- Modular system
- Service-friendly
- Built-in temperature switch for temperature monitoring
- Corrosion protected – the use of yellow metals has been avoided; only grey cast iron, surface treated aluminium, steel and stainless steel is used
- Double shaft seal

### Typical Applications

- In all areas of vacuum engineering
- Pumping of corrosive or aggressive media
- Production of semiconductors and in the area of chemistry
- Research and production
- Generation of rough and medium vacuum
- Backing pump in pump sets, i.e. in connection with Roots, diffusion, turbo or cryopumps

### Supplied Equipment

- Small flanges
- Centering, sealing and clamping rings
- The intake port includes a dirt trap

BCS pumps are supplied with a filling of standard oil LEYBONOL.

All pumps are subjected to a vacuum test before delivery!

### TRIVAC SYSTEM

The TRIVAC BCS and its accessories

- CFS, chemical filter with safety isolation valve
- ARS, exhaust filter with lubricant return
- IGS, inert gas system
- LSS, limit switch system

make up the TRIVAC SYSTEM.

### TRIVAC BCS-PFPE

In many applications the use of synthetic lubricants like perfluoropolyether (PFPE) offers superior characteristics compared to mineral oils.

Advantages of perfluoropolyether (PFPE) LEYBONOL LVO 400:

- Practically inert against all chemical and oxidizing influences
- No polymerization under the influence of high energy radiation
- In part significantly increased oil change intervals
- Thermally highly stable. Thermal decomposition will only occur at temperatures over 290 °C (554 °F)

BCS-PFPE pumps have been especially prepared for operation with LEYBONOL LVO 400 and are supplied **without** the oil filling.

We recommend using our operating fluid LEYBONOL LVO 400 and always to install a chemical oil filter CF or CFS.

# TRIVAC D 16 BCS to D 65 BCS

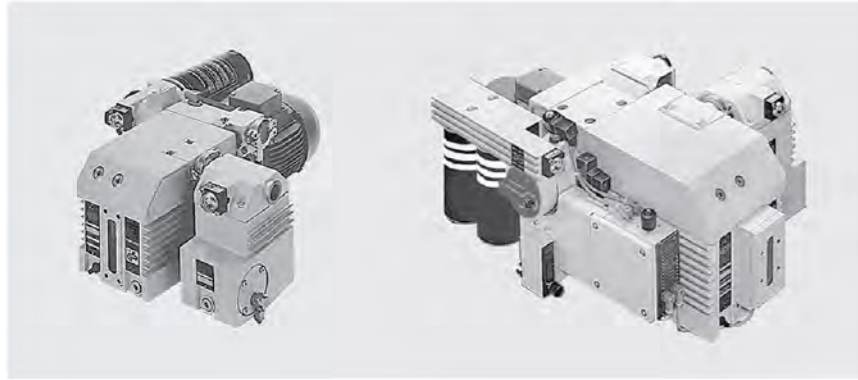

TRIVAC D 25 BCS with ARS and CFS (left)  
and TRIVAC D 65 BCS with CFS, ARS, IGS, LSS – TRIVAC SYSTEM (right)

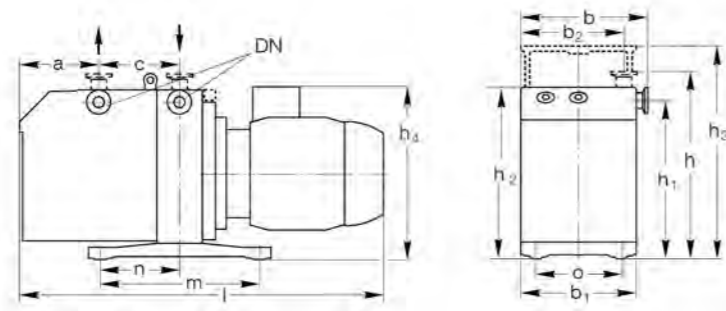

Type	DN		a	b	b <sub>1</sub>	b <sub>2</sub>	c	h	h <sub>1</sub>	h <sub>2</sub>	h <sub>3</sub>	h <sub>4</sub> <sup>1)</sup>	l <sup>1)</sup>	m	n	o
D 16 BCS (Part No. 113 68)	25 KF	mm	82	186	172	151	135	262	227	248	298	260	508	280	140	132
		in.	3.23	7.32	6.77	5.94	5.32	10.31	8.94	9.76	11.73	10.24	20.00	11.02	5.51	5.20
D 25 BCS (Part No. 113 78)	25 KF	mm	144	186	172	151	135	262	227	248	298	260	570	280	140	132
		in.	5.67	7.32	6.77	5.94	5.32	10.31	8.94	9.76	11.73	10.24	22.44	11.02	5.51	5.20
D 40 BCS (Part No. 113 88)	40 KF	mm	135	255	235	206	166	361	308	341	-	320	720	382	191	190
		in.	5.32	10.04	9.25	8.11	6.54	14.21	12.13	13.43	-	12.60	28.35	15.04	7.52	7.48
D 65 BCS (Part No. 113 98)	40 KF	mm	213	255	235	206	166	361	308	341	-	320	720	382	191	190
		in.	8.39	10.04	9.25	8.11	6.54	14.21	12.13	13.43	-	12.60	28.35	15.04	7.52	7.48

<sup>1)</sup> For dimensions h<sub>4</sub> and l for further part numbers, see paragraph "Motor Dependent Data for the TRIVAC B, BCS and BCS-PFPE"

Dimensional drawing for the TRIVAC D 16 to D 65 BCS

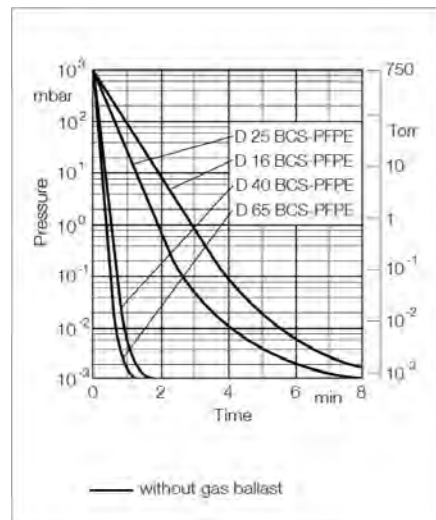

Pump-down characteristics of a 100 l vessel at 50 Hz

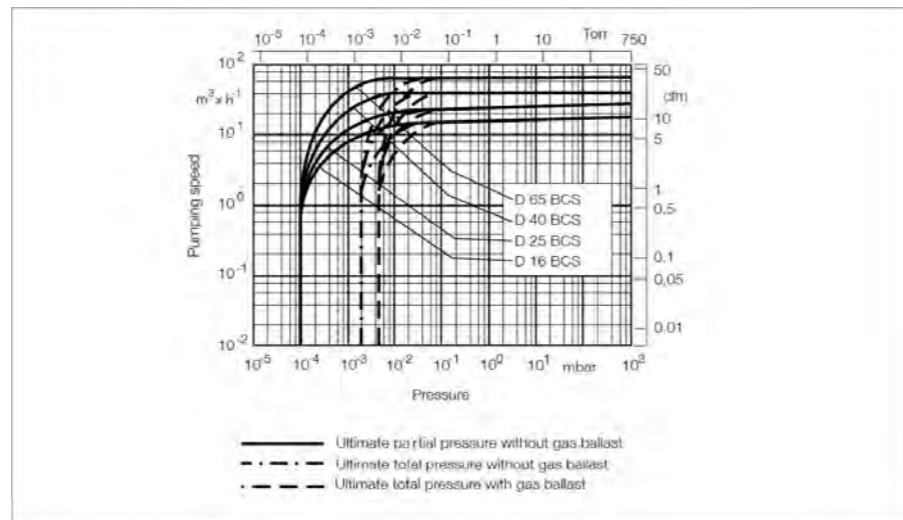

Pumping speed characteristics at 50 Hz (60 Hz curves at the end of the chapter)

## Technical Data

		TRIVAC D 16 BCS two-stage		TRIVAC D 25 BCS two-stage	
		50 Hz	60 Hz	50 Hz	60 Hz
Nominal pumping speed <sup>1)</sup>	m <sup>3</sup> /h (cfm)	18.9 (11.1)	22.7 (13.4)	29.5 (17.4)	35.4 (20.9)
Pumping speed <sup>1)</sup>	m <sup>3</sup> /h (cfm)	16.5 (9.7)	19.8 (11.7)	25.7 (15.1)	30.8 (18.2)
Ultimate partial pressure without gas ballast <sup>1)</sup>	mbar (Torr)	10 <sup>-4</sup> (0.75 x 10 <sup>-4</sup> )	10 <sup>-4</sup> (0.75 x 10 <sup>-4</sup> )	10 <sup>-4</sup> (0.75 x 10 <sup>-4</sup> )	10 <sup>-4</sup> (0.75 x 10 <sup>-4</sup> )
Ultimate total pressure without gas ballast <sup>1)</sup>	mbar (Torr)	≤ 2 x 10 <sup>-3</sup> (≤ 1.9 x 10 <sup>-3</sup> )	≤ 2 x 10 <sup>-3</sup> (≤ 1.9 x 10 <sup>-3</sup> )	≤ 2 x 10 <sup>-3</sup> (≤ 1.9 x 10 <sup>-3</sup> )	≤ 2 x 10 <sup>-3</sup> (≤ 1.9 x 10 <sup>-3</sup> )
Ultimate total pressure with gas ballast <sup>1)</sup>	mbar (Torr)	< 5 x 10 <sup>-3</sup> (< 3.8 x 10 <sup>-3</sup> )	< 5 x 10 <sup>-3</sup> (< 3.8 x 10 <sup>-3</sup> )	< 5 x 10 <sup>-3</sup> (< 3.8 x 10 <sup>-3</sup> )	< 5 x 10 <sup>-3</sup> (< 3.8 x 10 <sup>-3</sup> )
Water vapor tolerance <sup>1)</sup>	mbar (Torr)	25 (18.8)	25 (18.8)	25 (18.8)	25 (18.8)
Water vapor capacity	g/h (lbs/h)	305 (0.672)	370 (0.816)	476 (1.049)	570 (1.257)
Oil filling, min. / max.	l (qt)	0.45 / 1.2 (0.5 / 1.1)	0.45 / 1.2 (0.5 / 1.1)	0.45 / 1.2 (0.5 / 1.1)	0.45 / 1.2 (0.5 / 1.1)
Noise level <sup>2)</sup> to DIN 45 635, without / with gas ballast	dB(A)	54 / 56	54 / 56	54 / 56	54 / 56
Admissible ambient temperature	°C (°F)	+12 to +40 (+54 to +104)	+12 to +40 (+54 to +104)	+12 to +40 (+54 to +104)	+12 to +40 (+54 to +104)
Motor rating <sup>2)</sup>	W (HP)	750 (1.0)	750 (1.0)	750 (1.0)	750 (1.0)
Nominal speed	rpm	1425	1730	1425	1730
Type of protection	IP	3)	3)	3)	3)
Weight <sup>2)</sup>	kg (lbs)	28 (61.7)	28 (61.7)	32.3 (71.2)	32.3 (71.2)
Connections, Intake and Exhaust	DN	25 KF	25 KF	25 KF	25 KF

<sup>1)</sup> To DIN 28 400 and following numbers

<sup>2)</sup> Motor rating and noise levels for the pumps with AC motor 50 Hz.

Any data that deviate from the above for pumps with other motors, and other motor-dependent data are given in chapter "Products", paragraph "Motor Dependent Data for the TRIVAC B, BCS and BCS-PFPE".

<sup>3)</sup> See paragraph "Motor Dependent Data for the TRIVAC B, BCS and BCS-PFPE".

**Technical Data**

**TRIVAC D 40 BCS**

two-stage

**TRIVAC D 65 BCS**

two-stage

		<b>50 Hz</b>	<b>60 Hz</b>	<b>50 Hz</b>	<b>60 Hz</b>
Nominal pumping speed <sup>1)</sup>	m <sup>3</sup> /h (cfm)	46 (27)	55 (32.5)	75 (44)	90 (53)
Pumping speed <sup>1)</sup>	m <sup>3</sup> /h (cfm)	40 (24)	48 (28)	65 (38)	78 (46)
Ultimate partial pressure without gas ballast <sup>1)</sup>	mbar (Torr)	10 <sup>-4</sup> (0.75 x 10 <sup>-4</sup> )	10 <sup>-4</sup> (0.75 x 10 <sup>-4</sup> )	10 <sup>-4</sup> (0.75 x 10 <sup>-4</sup> )	10 <sup>-4</sup> (0.75 x 10 <sup>-4</sup> )
Ultimate total pressure without gas ballast <sup>1)</sup>	mbar (Torr)	≤ 2 x 10 <sup>-3</sup> (≤ 1.5 x 10 <sup>-3</sup> )	≤ 2 x 10 <sup>-3</sup> (≤ 1.5 x 10 <sup>-3</sup> )	≤ 2 x 10 <sup>-3</sup> (≤ 1.5 x 10 <sup>-3</sup> )	≤ 2 x 10 <sup>-3</sup> (≤ 1.5 x 10 <sup>-3</sup> )
Ultimate total pressure with gas ballast Stage <sup>1)</sup>	mbar (Torr)	< 5 x 10 <sup>-3</sup> (< 3.8 x 10 <sup>-3</sup> )	< 5 x 10 <sup>-3</sup> (< 3.8 x 10 <sup>-3</sup> )	< 5 x 10 <sup>-3</sup> (< 3.8 x 10 <sup>-3</sup> )	< 5 x 10 <sup>-3</sup> (< 3.8 x 10 <sup>-3</sup> )
Water vapor tolerance <sup>1)</sup>	mbar (Torr)	40 (30)	40 (30)	40 (30)	40 (30)
Water vapor capacity	g/h (lbs/h)	1184 (2.610)	1420 (3.131)	1925 (4.244)	2310 (5.093)
Oil filling, min. / max.	l (qt)	1.7 / 2.6 (1.8 / 2.7)	1.7 / 2.6 (1.8 / 2.7)	2.0 / 3.3 (2.1 / 3.5)	2.0 / 3.3 (2.1 / 3.5)
Noise level <sup>2)</sup> to DIN 45 635, without / with gas ballast	dB(A)	57 / 59	57 / 59	57 / 59	57 / 59
Admissible ambient temperature	°C (°F)	+12 to +40 (+54 to +104)	+12 to +40 (+54 to +104)	+12 to +40 (+54 to +104)	+12 to +40 (+54 to +104)
Motor rating <sup>2)</sup>	W (HP)	2200 (3.0)	2200 (3.0)	2200 (3.0)	2200 (3.0)
Nominal speed	rpm	1460	1760	1460	1760
Type of protection	IP	3)	3)	3)	3)
Weight <sup>2)</sup>	kg (lbs)	75.3 (166)	75.3 (166)	84.5 (186.3)	84.5 (186.3)
Connections, Intake and Exhaust	DN	40 KF	40 KF	40 KF	40 KF

<sup>1)</sup> To DIN 28 400 and following numbers

<sup>2)</sup> Motor rating and noise levels for the pumps with AC motor 50 Hz.

Any data that deviate from the above for pumps with other motors, and other motor-dependent data are given in chapter "Products", paragraph "Motor Dependent Data for the TRIVAC B, BCS and BCS-PFPE".

<sup>3)</sup> See paragraph "Motor Dependent Data for the TRIVAC B, BCS and BCS-PFPE".

**Ordering Information**

	<b>TRIVAC D 16 BCS two-stage</b>	<b>TRIVAC D 25 BCS two-stage</b>	<b>TRIVAC D 40 BCS two-stage</b>	<b>TRIVAC D 65 BCS two-stage</b>
	<b>Part No.</b>	<b>Part No.</b>	<b>Part No.</b>	<b>Part No.</b>
<b>TRIVAC B</b>				
with 3-phase motor				
200 – 240 V (200 V IE3) /				
380 – 400 V (380 – 400 V IE3), 50 Hz /				
200 – 240 (208 – 240 V IE3) /				
400 – 480 V (416 – 480 V IE3), 60 Hz	<b>113 68</b>	<b>113 78</b>	-	-
200 – 240 V (200 V IE3) /				
380 – 400 V (380 – 400 V IE3), 50 Hz /				
200 – 240 (208 – 240 V IE3) /				
400 – 480 V (416 – 480 V IE3), 60 Hz	-	-	<b>113 88</b>	<b>113 98</b>
<b>Accessories</b>				
Roots pump adaptor	-	-	<b>168 30</b>	<b>168 30</b>
Exhaust filter with lubricant return				
AK 16-25	<b>189 56</b>	<b>189 56</b>	-	-
AK 40-65	-	-	<b>189 57</b>	<b>189 57</b>
Condensate separator				
AK 16-25	<b>188 11</b>	<b>188 11</b>	-	-
AK 40-65	-	-	<b>188 16</b>	<b>188 16</b>
Chemical filter with safety blocking valve				
CFS 16-25	<b>101 76</b>	<b>101 76</b>	-	-
CFS 40-65	-	-	<b>101 77</b>	<b>101 77</b>
Inert gas system				
IGS 16-25	<b>161 76</b>	<b>161 76</b>	-	-
IGS 40-65	-	-	<b>161 68V</b>	<b>161 68V</b>
Limit switch system				
LSS 16-25	<b>161 06</b>	<b>161 06</b>	-	-
LSS 40-65	-	-	<b>161 07</b>	<b>161 07</b>
<b>Spare Parts</b>				
Inner body	<b>E 200 39 762</b>	<b>E 200 39 764</b>	<b>E 200 39 758</b>	<b>E 200 39 760</b>
Major maintenance kit (without oil)	<b>EK110002646</b>	<b>EK110002647</b>	<b>EK110002641</b>	<b>EK110002642</b>
Minor maintenance kit (without oil)	<b>EK110002649</b>	<b>EK110002648</b>	<b>EK110002624</b>	<b>EK110002624</b>
Shaft sealing replacement kit	<b>EK110002650</b>	<b>EK110002650</b>	<b>EK110002643</b>	<b>EK110002643</b>
Seal kit	<b>197 31</b>	<b>197 31</b>	<b>197 32</b>	<b>197 32</b>

For further accessories see section "Accessories for TRIVAC E, B and BCS".

# TRIVAC D 16 BCS-PFPE to D 65 BCS-PFPE

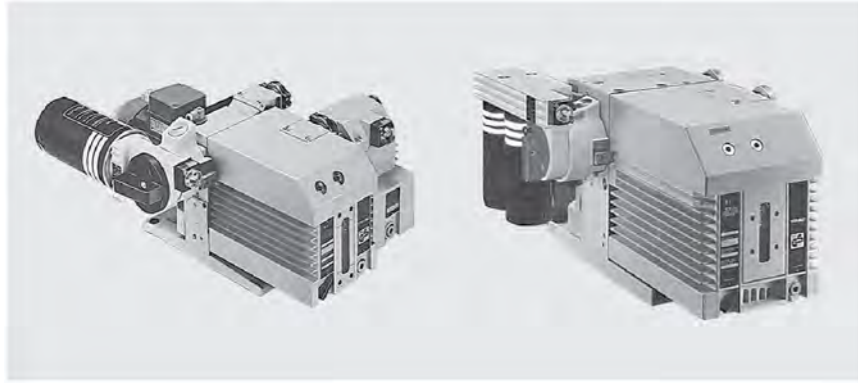

TRIVAC D 25 BCS-PFPE with CFS 16-25 and ARS 16-25 (left) and TRIVAC D 65 BCS-PFPE with CFS 40-65 (right)

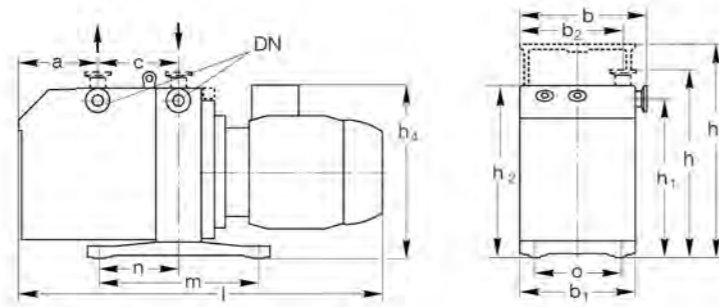

Type	DN		a	b	b <sub>1</sub>	b <sub>2</sub>	c	h	h <sub>1</sub>	h <sub>2</sub>	h <sub>3</sub>	h <sub>4</sub>	l	m	n	o
D 16 BCS (Part No. 113 69)	25 KF	mm	82	190	175	150	135	263	226	250	298	260	508	280	140	132
		in.	3.23	7.48	6.89	5.91	5.32	10.35	8.90	9.84	11.73	10.24	20.00	11.02	5.51	5.20
D 25 BCS (Part No. 113 79)	25 KF	mm	142	190	175	150	135	263	226	250	298	260	508	280	140	132
		in.	5.59	7.48	6.89	5.91	5.32	10.35	8.90	9.84	11.73	10.24	20.00	11.02	5.51	5.20
D 40 BCS (Part No. 113 89)	40 KF	mm	135	285	264	206	166	355	308	336	-	317	719	382	191	190
		in.	5.32	11.22	10.39	8.11	6.54	13.98	12.13	13.23	-	12.48	28.31	15.04	7.52	7.48
D 65 BCS (Part No. 113 99)	40 KF	mm	213	285	264	206	166	355	308	336	-	317	719	382	191	190
		in.	8.39	11.22	10.39	8.11	6.54	13.98	12.13	13.23	-	12.48	28.31	15.04	7.52	7.48

<sup>1)</sup> For dimensions h<sub>4</sub> and l for further part numbers, see paragraph "Motor Dependent Data for the TRIVAC B, BCS and BCS-PFPE"

Dimensional drawing for the TRIVAC D 16 to D 65 BCS-PFPE

## Technical Data

		TRIVAC D 16 BCS-PFPE two-stage		TRIVAC D 25 BCS-PFPE two-stage	
		50 Hz	60 Hz	50 Hz	60 Hz
Nominal pumping speed <sup>1)</sup>	m <sup>3</sup> /h (cfm)	18.9 (11.1)	22.7 (13.4)	29.5 (17.4)	35.4 (20.9)
Pumping speed <sup>1)</sup>	m <sup>3</sup> /h (cfm)	16.5 (9.7)	19.8 (11.7)	25.7 (15.1)	30.8 (18.2)
Ultimate partial pressure without gas ballast <sup>1)</sup>	mbar (Torr)	< 8 × 10 <sup>-4</sup> (< 6 × 10 <sup>-4</sup> )	< 8 × 10 <sup>-4</sup> (< 6 × 10 <sup>-4</sup> )	< 8 × 10 <sup>-4</sup> (< 6 × 10 <sup>-4</sup> )	< 8 × 10 <sup>-4</sup> (< 6 × 10 <sup>-4</sup> )
Ultimate total pressure with gas ballast Stage <sup>1)</sup>	mbar (Torr)	< 5 × 10 <sup>-3</sup> (< 3.8 × 10 <sup>-3</sup> )	< 5 × 10 <sup>-3</sup> (< 3.8 × 10 <sup>-3</sup> )	< 5 × 10 <sup>-3</sup> (< 3.8 × 10 <sup>-3</sup> )	< 5 × 10 <sup>-3</sup> (< 3.8 × 10 <sup>-3</sup> )
Lubricant filling min. / max. upon delivery	l (qt)	0.45 / 1.0 (0.5 / 1.1)	0.45 / 1.0 (0.5 / 1.1)	0.6 / 1.4 (0.6 / 1.5)	0.6 / 1.4 (0.6 / 1.5)
	l (qt)	0.2 (0.2)	0.2 (0.2)	0.4 (0.4)	0.4 (0.4)
Noise level <sup>2)</sup> to DIN 45 635, without / with gas ballast	dB(A)	54 / 56	54 / 56	54 / 56	54 / 56
Admissible ambient temperature	°C (°F)	+12 to +40 (+54 to +104)	+12 to +40 (+54 to +104)	+12 to +40 (+54 to +104)	+12 to +40 (+54 to +104)
Motor rating <sup>2)</sup>	W (HP)	750 (1.0)	750 (1.0)	750 (1.0)	750 (1.0)
Nominal speed	rpm	1425	1730	1425	1730
Type of protection	IP	<sup>3)</sup>	<sup>3)</sup>	<sup>3)</sup>	<sup>3)</sup>
Weight <sup>2)</sup>	kg (lbs)	29.3 (64.5)	29.3 (64.5)	33.8 (74.4)	33.8 (74.4)
Connections, Intake and Exhaust	DN	25 KF	25 KF	25 KF	25 KF

<sup>1)</sup> To DIN 28 400 and following numbers

<sup>2)</sup> Motor rating and noise levels for the pumps with AC motor 50 Hz.

Any data that deviate from the above for pumps with other motors, and other motor-dependent data are given in chapter "Products", paragraph "Motor Dependent Data for the TRIVAC B, BCS and BCS-PFPE".

<sup>3)</sup> See paragraph "Motor Dependent Data for the TRIVAC B, BCS and BCS-PFPE".

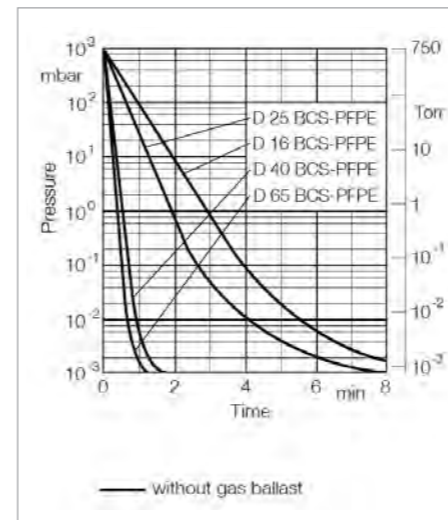

Pump-down characteristics of a 100 l vessel at 50 Hz

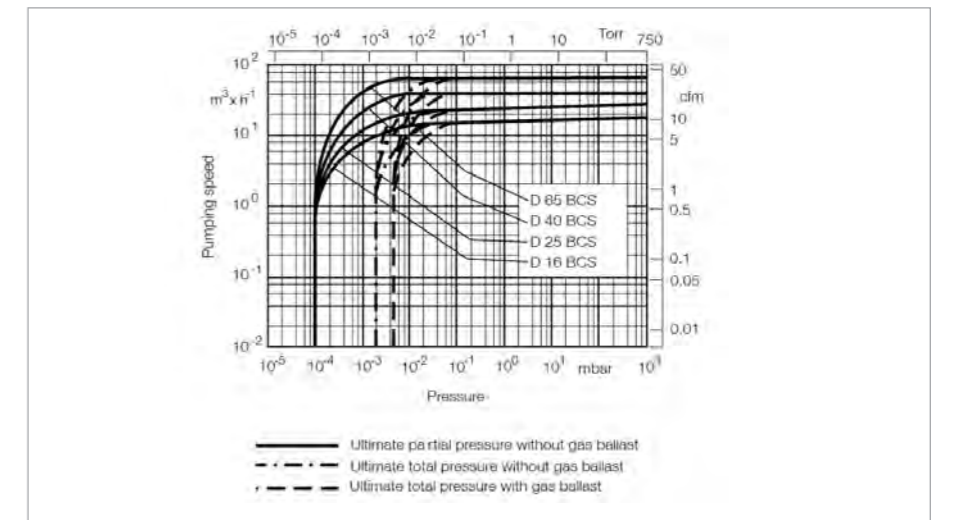

Pumping speed characteristics at 50 Hz (60 Hz curves at the end of the chapter)

**Technical Data**

**TRIVAC D 40 BCS-PFPE**

**two-stage**

**50 Hz**

**60 Hz**

**TRIVAC D 65 BCS-PFPE**

**two-stage**

**50 Hz**

**60 Hz**

Nominal pumping speed <sup>1)</sup>	m <sup>3</sup> /h (cfm)	46 (27)	55 (32.5)	75 (44)	90 (53)
Pumping speed <sup>1)</sup>	m <sup>3</sup> /h (cfm)	40 (24)	48 (28)	65 (38)	78 (46)
Ultimate partial pressure without gas ballast <sup>1)</sup>	mbar (Torr)	< 8 x 10 <sup>-4</sup> (< 6 x 10 <sup>-4</sup> )	< 8 x 10 <sup>-4</sup> (< 6 x 10 <sup>-4</sup> )	< 8 x 10 <sup>-4</sup> (< 6 x 10 <sup>-4</sup> )	< 8 x 10 <sup>-4</sup> (< 6 x 10 <sup>-4</sup> )
Ultimate total pressure with gas ballast <sup>1)</sup>	mbar (Torr)	< 5 x 10 <sup>-3</sup> (< 3.8 x 10 <sup>-3</sup> )	< 5 x 10 <sup>-3</sup> (< 3.8 x 10 <sup>-3</sup> )	< 5 x 10 <sup>-3</sup> (< 3.8 x 10 <sup>-3</sup> )	< 5 x 10 <sup>-3</sup> (< 3.8 x 10 <sup>-3</sup> )
Lubricant filling min. / max. upon delivery	l (qt)	1.7 / 2.6 (1.8 / 2.7)	1.7 / 2.6 (1.8 / 2.7)	2.0 / 3.3 (2.1 / 3.5)	2.0 / 3.3 (2.1 / 3.5)
	l (qt)	0.6 (0.6)	0.6 (0.6)	0.75 (0.8)	0.75 (0.8)
Noise level <sup>2)</sup> to DIN 45 635, without / with gas ballast	dB(A)	57 / 59	57 / 59	57 / 59	57 / 59
Admissible ambient temperature	°C (°F)	+12 to +40 (+54 to +104)	+12 to +40 (+54 to +104)	+12 to +40 (+54 to +104)	+12 to +40 (+54 to +104)
Motor rating <sup>2)</sup>	W (HP)	2200 (3.0)	2200 (3.0)	2200 (3.0)	2200 (3.0)
Nominal speed	rpm	1460	1760	1460	1760
Type of protection	IP	<sup>3)</sup>	<sup>3)</sup>	<sup>3)</sup>	<sup>3)</sup>
Weight <sup>2)</sup>	kg (lbs)	77.9 (171.8)	77.9 (171.8)	87.9 (193.7)	87.9 (193.7)
Connections, Intake and Exhaust	DN	40 KF	40 KF	40 KF	40 KF

<sup>1)</sup> To DIN 28 400 and following numbers

<sup>2)</sup> Motor rating and noise levels for the pumps with AC motor 50 Hz. Any data that deviate from the above for pumps with other motors, and other motor-dependent data are given in chapter "Products", paragraph "Motor Dependent Data for the TRIVAC B, BCS and BCS-PFPE".

<sup>3)</sup> See paragraph "Motor Dependent Data for the TRIVAC B, BCS and BCS-PFPE".

**Ordering Information**

**TRIVAC D 16 BCS-PFPE two-stage**

**TRIVAC D 25 BCS-PFPE two-stage**

**TRIVAC D 40 BCS-PFPE two-stage**

**TRIVAC D 65 BCS-PFPE two-stage**

	Part No.	Part No.	Part No.	Part No.
<b>TRIVAC B with 3-phase motor</b> 200 – 240 V (200 V IE3) / 380 – 400 V (380 – 400 V IE3), 50 Hz / 200 – 240 (208 – 240 V IE3) / 400 – 480 V (416 – 480 V IE3), 60 Hz	<b>113 69</b>	<b>113 79</b>	-	-
200 – 240 V (200 V IE3) / 380 – 400 V (380 – 400 V IE3), 50 Hz / 200 – 240 (208 – 240 V IE3) / 400 – 480 V (416 – 480 V IE3), 60 Hz	-	-	<b>113 89</b>	<b>113 99</b>
<b>Accessories</b>				
Roots pump adaptor	-	-	<b>168 30</b>	<b>168 30</b>
Exhaust filter with lubricant return ARS 16-25 AK 40-65	<b>189 56</b> -	<b>189 56</b> -	- <b>189 57</b>	- <b>189 57</b>
Condensate trap AK 16-25 AK 40-65	<b>188 11</b> -	<b>188 11</b> -	- <b>188 16</b>	- <b>188 16</b>
Chemical filter with safety blocking valve CFS 16-25 CFS 40-65	<b>101 76</b> -	<b>101 76</b> -	- <b>101 77</b>	- <b>101 77</b>
Inert gas system IGS 16-25 IGS 40-65	<b>161 76</b> -	<b>161 76</b> -	- <b>161 68V</b>	- <b>161 68V</b>
Limit switch system LSS 16-25 LSS 40-65	<b>161 06</b> -	<b>161 06</b> -	- <b>161 07</b>	- <b>161 07</b>
<b>Spare Parts</b>				
Major maintenance kit, LVO 400 (without oil)	<b>EK110002644</b>	<b>EK110002645</b>	<b>EK110002637</b>	<b>EK110002638</b>
Shaft sealing replacement kit	<b>EK110002650</b>	<b>EK110002650</b>	<b>EK110002643</b>	<b>EK110002643</b>
Seal kit	<b>197 41</b>	<b>197 41</b>	<b>197 42</b>	<b>197 42</b>





For further accessories see section "Accessories for TRIVAC E, B and BCS".



# Motor Dependent Data for the TRIVAC B, BCS and BCS-PFPE

Pump type		D 4 / 8 B	D 4 / 8 B	D 4 / 8 B	D 4 / 8 B
Part No. of the pump		140 081, 140 082	112 45, 112 55	112 46, 112 56 112 5631, 140 246	140 140, 140 150
Motor part number		100002292	6507733	6508538	20010406
Size		80	71	71	71L
Protection class		IP 54	IP 55	IP 55	IP 55
Operating mode in acc. w. IEC 34 / NEMA		S1	S1	S1	S1
Insulation class		F	F	F	F
Phases		1~	1~	3~	3~
Efficiency class		-	-	-	-
Number of poles		4	4	4	4
Nominal output power at 50 Hz		570 W	370 W	370 W	370 W
Nominal output power at 60 Hz		660 W	-	440 W	-
Nominal input frequency		50 Hz / 60 Hz	50 Hz	50 Hz / 60 Hz	50 Hz
Tolerances of voltage range		±10 %	±5 %	±10 %	±5 %
Nominal voltage range and nominal current at 50 Hz		100 – 115 V / 7.7 A 210 – 230 V / 4.0 A	230 V / 3.0 A -	200 – 240 V / 2.3 A 380 – 400 V / 1.07 A	219 – 242 V / 1.84 A 380 – 420 V / 1.06 A
Nominal voltage range and nominal current at 60 Hz		100 – 115 V / 7.7 A 210 – 230 V / 4.0 A	- -	200 – 240 V / 2.15 A 380 – 480 V / 1.07 A	- -
Nominal output power at 50 Hz	rpm	1420	1410	1430	1390
Nominal output power at 60 Hz	rpm	1690	-	1735	-
Maximum operating altitude above sea level		1000 m	1000 m	1000 m	1000 m
Max. ambient temperature during operation	°C (°F)	40 (104)	40 (104)	40 (104)	40 (104)
Terminal board / plug		Multi-pin plug at junction box, mains cord E20081091 (1.8 m) with Schuko plug CEE 7/7 (included in delivery), mains cord E20081097 (1.8 m) with UK plug BS 1363 (optional), mains cord E20081099 (1.8 m) with CH plug SEV 1011 (optional), mains cord E20081141 (1.8 m) with US plug NEMA 6-15P (optional)	Mains cord (2 m) with Schuko plug CEE	9 pins	6 pins
Certifications					
Shaft dimension $\varnothing d / l$	mm (in.)	14 / 30 (0.55 / 1.18)	14 / 30 (0.55 / 1.18)	14 / 30 (0.55 / 1.18)	14 / 30 (0.55 / 1.18)
Size of flange A/B	mm (in.)	140 / 95 (5.51 / 3.74)	140 / 95 (5.51 / 3.74)	140 / 95 (5.51 / 3.74)	140 / 95 (5.51 / 3.74)
Length of the pump	mm (in.)	458 (18.03) (D 4 B) 482 (18.98) (D 8 B)	442 (18.11) (D 4 B) 467 (19.06) (D 8 B)	458 (18.62) (D 4 B) 482 (18.98) (D 8 B)	438 (17.24) (D 4 B) 462 (18.19) (D 8 B)
Height up to top edge of junction box $h_4$	mm (in.)	254 (10.0)	243 (9.57)	247 (9.72)	241 (9.49)

# Only available for purchase in North and South America

Pump type		D 8 B
Part No. of the pump		898 974
Motor part number		72260196
Size		56C
Protection class		TEFC
Operating mode in acc. w. IEC 34 / NEMA		continuous
Insulation class		B
Phases		1~
Efficiency class		-
Number of poles		4
Nominal output power at 50 Hz		240 W
Nominal output power at 60 Hz		370 W
Nominal input frequency		50 Hz / 60 Hz
Tolerances of voltage range		±5 %
Nominal voltage range and nominal current at 50 Hz		110 V / 9.6 A 220 V / 4.8 A
Nominal voltage range and nominal current at 60 Hz		115 V / 8.8 A 208-230 V / 4.5 A
Nominal output power at 50 Hz	rpm	1425
Nominal output power at 60 Hz	rpm	1725
Maximum operating altitude above sea level		1000 m
Max. ambient temperature during operation	°C (°F)	40 (104)
Terminal board / plug		12 pin plug at the motor, mains cord (1.8 m) E72127874 with US plug NEMA 5-15P (115 V) (optional)
Certifications		
Shaft dimension $\varnothing d / l$	mm (in.)	15.87 / 52.32 (0.63 / 2.06)
Size of flange A/B	mm (in.)	114.3 (4.5)
Length of the pump	mm (in.)	557 (21.93) (D 8 B)
Height up to top edge of junction box $h_4$	mm (in.)	287 (11.30)

Pump type	D 16 / 25 B D 16 / 25 BCS D 16 / 25 BCS-PFPE D 16 / 25 B-DOT	D 16 / 25 B	D 16 / 25 B (3i/3o)	D 16 B-Ex
Part No. of the pump	112 66, 112 76, 113 33 914 63-1 114 06, 114 10, 112 76 18 113 68, 113 78, 113 69, 113 79	112 66J, 112 76J, 113 33J, 113 98J	140 160, 140 170	140 091, 140 092
Motor part number	6506939	6520730	20010409	100002330
Size	80	80Z	80L	80L
Protection class	IP 55	IP 55	IP 55	IP 55
Operating mode in acc. w. IEC 34 / NEMA	S1	S1	S1	S1
Insulation class	F	F	F	F
Phases	3~	3~	3~	3~
Efficiency class	IE3	IE3 Japan	-	-
Number of poles	4	4	4	4
Nominal output power at 50 Hz at 60 Hz	750 W 750 W	750 W 750 W	750 W -	750 W -
Nominal input frequency	50 Hz / 60 Hz	50 Hz / 60 Hz	50 Hz	50 Hz
Tolerances of voltage range	±10 %	±5 %	±5 %	±5 %
Nominal voltage range and nominal current at 50 Hz	200 – 240 V / 3.8 A 200 V / 3.8 A (IE3) 380 – 400 V / 1.9 A 380 – 400 V / 1.9 A (IE3)	180 – 220 V / 3.6 A 200 V / 3.6 A (IE3) 311 – 380 V / 2.1 A 346 V / 1.9 A (IE3)	219 – 242 V / 3.35 A - 380 – 420 / 1.94 A -	219 – 242 V / 3.4 A - 380 – 420 / 1.95 A -
at 60 Hz	200 – 240 V / 3.4 A 208 – 240 V / 3.4 A (IE3) 380 – 480 V / 1.9 A 416 – 480 V / 1.7 A (IE3)	200 – 240 V / 3.4 A 220 V / 3.1 A (IE3) 342 – 418 V / 1.9 A 380 V / 1.8 A (IE3)	- - - -	- - - -
Nominal output power at 50 Hz at 60 Hz	rpm rpm	1425 1730	1440 1745	1380 -
Maximum operating alti- tude above sea level	1000 m	1000 m	1000 m	1000 m
Max. ambient temperature during operation	°C (°F)	40 (104)	40 (104)	40 (104)
Terminal board / plug	9 pins	9 pins	6 pins	6 pins
Certifications	 RoHS	 RoHS	 II 2 G Ex e II T3	 II 2 G Ex e II T4
Shaft dimension $\varnothing d / l$	mm (in.)	19 / 40 (0.75 / 1.58)	19 / 40 (0.75 / 1.58)	19 / 40 (0.75 / 1.58)
Size of flange A/B	mm (in.)	160 / 110 (6.30 / 4.33)	160 / 110 (6.30 / 4.33)	160 / 110 (6.30 / 4.33)
Length of the pump	mm (in.)	509 (20.4) (D 16 B) 570 (22.44) (D 25 B)	509 (20.4) (D 16 B) 570 (22.44) (D 25 B)	510 (20.08) (D 16 B) 572 (22.52) (D 25 B)
Height up to top edge of junction box $h_4$	mm (in.)	260 (10.24)	260 (10.24)	268 (10.55)

Pump type	D 16 / 25 B	D 16 / 25 B	D 16 B
Part No. of the pump	112 65, 112 75	113 25, 113 35	898 698
Motor part number	38066003	110001212	72260187
Size	90	90	56C
Protection class	IP 44	IP 54	IP 44
Operating mode in acc. w. IEC 34 / NEMA	S1	H	continuous
Insulation class	F	F	F
Phases	1~	1~	1~
Efficiency class	-	-	-
Number of poles	4	4	4
Nominal output power at 50 Hz at 60 Hz	750 W 750 W	750 W 750 W	750 W 750 W
Nominal input frequency	50 Hz / 60 Hz	50 Hz / 60 Hz	50 Hz / 60 Hz
Tolerances of voltage range	±5 %	±5 %	±5 %
Nominal voltage range and nominal current at 50 Hz	218 – 242 V / 5.0 – 5.6 A -	208 – 252 V / 5.7 A -	110 V / 15.0 A 220 V / 7.5 A
at 60 Hz	218 – 242 V / 5.0 – 5.6 A -	208 – 252 V / 4.9 A -	115 V / 12.4 A 208 – 230 V / 6.3 – 6.2 A
Nominal output power at 50 Hz at 60 Hz	rpm rpm	1460 1750	1420 1680
Maximum operating alti- tude above sea level	1000 m	1000 m	1000 m
Max. ambient temperature during operation	°C (°F)	40 (104)	40 (104)
Terminal board / plug	Mains cord (2 m) with Schuko plug CEE	Multi-pin plug at junc- tion box, mains cord E20081091 (1.8 m) with Schuko plug CEE 7/7 (Included in delivery), mains cord E20081097 (1.8 m) with UK plug BS 1363 (optional), mains cord E20081099 (1.8 m) with CH plug SEV 1011 (optional), mains cord E20081141 (1.8 m) with US plug NEMA 6-15P (230 V) (optional)	Multi-pin plug at junc- tion box, mains cord (1.8 m) E72127877 with US plug NEMA 5-15P (115 V) (included in delivery), mains cord (1.8 m) E72127878 with US plug NEMA 6-15P (230 V) (included in delivery), mains cord (1.8 m) E72127875 with US Plug NEMA 6-15P (115 V) (optional), mains cord (1.8 m) E72127874 with US Plug NEMA FEM (230 V) (optional),
Certifications			
Shaft dimension $\varnothing d / l$	mm (in.)	19 / 40 (0.75 / 1.58)	15.87 / 53.32 (0.63 / 2.06)
Size of flange A/B	mm (in.)	160 / 110 (6.30 / 4.33)	114.3 (4.5)
Length of the pump	mm (in.)	521 (20.51) (D 16 B) 583 (22.95) (D 25 B)	505 (19.88) (D 16 B) 567 (22.32) (D 25 B)
Height up to top edge of junction box $h_4$	mm (in.)	278 (10.95)	279 (10.98)

Pump type	<b>D 40 / 65 B</b> <b>D 40 / 65 BCS</b> <b>D 40 / 65 BCS-PFPE</b> <b>D 40 B-DOT + D 65 B <sup>3</sup>He</b>	<b>D 40 / 65 B</b>	<b>D 40 / 65 B-Ex</b>
Part No. of the pump	112 86, 112 96 113 88, 113 98 113 89, 113 99 112 86 12 / 112 96 46	112 86J, 112 96J, 112 98J	140 180, 140 190
Motor part number	6506961	6520731	20010411
Size	100L	100L	100L
Protection class	IP 55	IP 55	IP 55
Operating mode in acc. w. IEC 34 / NEMA	S1	S1	S1
Insulation class	F	F	F
Phases	3~	3~	3~
Efficiency class	IE3	IE3 Japan	-
Number of poles	4	4	4
Nominal output power at 50 Hz	2200 W	2200 W	2200 W
at 60 Hz	2200 W	2200 W	-
Nominal input frequency	50 Hz / 60 Hz	50 Hz / 60 Hz	50 Hz
Tolerances of voltage range	10 %	10 %	±5 %
Nominal voltage range and nominal current at 50 Hz	200 – 240 V / 9.0 A 200 V / 9.0 A (IE3) 380 – 400 V / 4.5 A 380 – 400 V / 4.5 A (IE3)	180 – 220 V / 9.7 A 200 V / 9.7 A (IE3) 311 – 380 V / 5.6 A 346 V / 5.6 A (IE3)	219 – 242 V / 10.1 A - 380 – 420 V / 5.8 A -
at 60 Hz	200 – 240 V / 8.8 A 208 – 240 V / 7.8 A (IE3) 400 – 480 V / 4.4 A 416 – 480 V / 3.9 A (IE3)	200 – 240 V / 8.8 A 220 V / 8.5 A (IE3) 342 – 418 V / 4.9 A 380 V / 4.9 A (IE3)	- - - -
Nominal output power at 50 Hz	rpm	1460	1460
at 60 Hz	rpm	1760	1760
Maximum operating altitude above sea level	1000 m	1000 m	1000 m
Max. ambient temperature during operation	°C (°F)	40 (104)	40 (104)
Terminal board / plug	9 pins	9 pins	6 pins
Certifications			
Shaft dimension ø d / l	mm (in.)	28 / 60 (1.10 / 2.36)	28 / 60 (1.10 / 2.36)
Size of flange A/B	mm (in.)	160 / 110 (6.30 / 4.33)	160 / 110 (6.30 / 4.33)
Length of the pump	mm (in.)	720 (28.35) (D 40 B) 797 (31.38) (D 65 B)	720 (28.35) (D 40 B) 797 (31.38) (D 65 B)
Height up to top edge of junction box h <sub>4</sub>	mm (in.)	317 (12.48)	317 (12.48)

## Accessories

For TRIVAC E, B and BCS  
Exhaust Filters AF 8 to AF 25-S  
Condensate Traps AK 8 to AK 25



Exhaust filter (left) and condensate trap (right)

### Exhaust-Filter

Oil mists and aerosols are retained in the exhaust filter.

#### Advantages to the User

- Filtering of the exhaust gas by removal of entrained lubricant particles
- Emptying via drain screw
- Separation efficiency > 99%
- Filter elements (made of glass fiber) are exchangeable

### Condensate Trap

Condensate traps prevent the formation of condensate in the pump as well as the backstreaming of fluids.

#### Advantages to the User

- Can be connected to either the intake or the exhaust side
- Protects against condensate forming from sucked in vapors or gases (intake line)
- Protects against backstreaming liquids (exhaust line)
- Emptying via drain screw

### Technical Information

The exhaust filter is not capable of retaining toxic and/or aggressive gases. For such applications we recommend the use of an exhaust gas line (e.g. a gas washer).

Since the material is not resistant to all gases and solvents, a materials compatibility chart is available upon request.

Type	a	b	b <sub>1</sub>	d	h	h <sub>1</sub>
AF 8 / AK 8	mm 66.4 in. 2.61	mm 115 in. 4.53	mm 57.5 in. 2.26	mm 20 in. 0.79	mm 145 in. 5.71	mm 15.5 in. 0.61
AF 10 / AK 10	mm 90 in. 3.54	mm 140 in. 5.51	mm 70 in. 2.76	mm 20 in. 0.79	mm 200 in. 7.87	mm 22 in. 0.87
AF 16-S / AK 16	mm 115 in. 4.53	mm 165 in. 6.50	mm 82.5 in. 3.25	mm 20 in. 0.79	mm 210 in. 8.27	mm 30 in. 1.18
AF 25-S / AK 25	mm 115 in. 4.53	mm 165 in. 6.50	mm 82.5 in. 3.25	mm 20 in. 0.79	mm 250 in. 9.84	mm 30 in. 1.18

**Technical Data**      **AF 8**    **AK 8**    **AF 10**    **AK 10**    **AF 16-S**    **AK 16**    **AF 25-S**    **AK 25**

Connection to pump (required accessories for TRIVAC E: elbow)	TRIVAC	D 2,5 E D 4 B D 8 B	D 2,5 E D 4 B D 8 B	D 16 B	D 16 B	D 16 B	D 16 B	D 16 B D 25 B	D 16 B D 25 B
Connection flanges	DN	16 KF	16 KF	25 KF	25 KF	25 KF	25 KF	25 KF	25 KF
Max. filling level (for vertical installation)	ml	60	60	145	145	285	285	285	285
Permissible leak rate	mbar x l/s	≤ 1 x 10 <sup>-5</sup>	≤ 1 x 10 <sup>-5</sup>	≤ 1 x 10 <sup>-5</sup>	≤ 1 x 10 <sup>-5</sup>	≤ 1 x 10 <sup>-5</sup>	≤ 1 x 10 <sup>-5</sup>	≤ 1 x 10 <sup>-5</sup>	≤ 1 x 10 <sup>-5</sup>
Max. continuous temperature	°C (°F)	90 (194)	90 (194)	90 (194)	90 (194)	90 (194)	90 (194)	90 (194)	90 (194)
Material		Polyamide 6	Polyamide 6	Polyamide 6	Polyamide 6	Polyamide 6	Polyamide 6	Polyamide 6	Polyamide 6

**Ordering Information**      **AF 8**    **AK 8**    **AF 10**    **AK 10**    **AF 16-S**    **AK 16**    **AF 25-S**    **AK 25**

	Part No.	Part No.	Part No.	Part No.	Part No.	Part No.	Part No.	Part No.
Exhaust filter	190 50	-	190 51	-	190 54	-	190 55	-
Condensate trap	-	190 60	-	190 61	-	190 62	-	190 63
Replacement filter element FE 8 (pack of 5)	ES 190 80	-	-	-	-	-	-	-
FE 10 (pack of 5)	-	-	ES 190 81	-	-	-	-	-
FE 16	-	-	-	-	ES 190 84	-	-	-
FE 25	-	-	-	-	-	-	ES 190 85	-
Reducer DN 25/16 KF <sup>1)</sup> Aluminium (if necessary)	183 86	183 86	183 86	183 86	183 86	183 86	183 86	183 86
Elbow (1x) Aluminium	184 36	184 36	184 37	184 37	184 37	184 37	184 37	184 37
Centering ring with O-ring (2x) Aluminium / FKM Stainless steel / FPM	182 06 883 46	182 06 883 46	182 07 883 47	182 07 883 47	182 07 883 47	182 07 883 47	182 07 883 47	182 07 883 47
Clamping ring (2x)	183 41	183 41	183 42	183 42	183 42	183 42	183 42	183 42

<sup>1)</sup> When using the reducer, an elbow is required

# Exhaust Filters

## AF 4-8 to AF 40-65

### AF 16-25 DOT and AF 40-65 DOT



AF 4-8 exhaust filter

Exhaust filters retain oil mists and aerosols.

**Advantages to the User**

- Can be fitted without additional accessories
- Separation efficiency over 99 %
- Exchangeable filter inserts
- Built-in over-pressure relief valve (threshold at about 1.5 bar (7.2 psi, differential))
- Sight glass for checking of the quantity of collected oil
- Resistant against solvents
- Seals for AF made of FPM (FKM)  
AF-DOT made of EPDM
- Easy to clean and use
- Retains dirt and cracked products

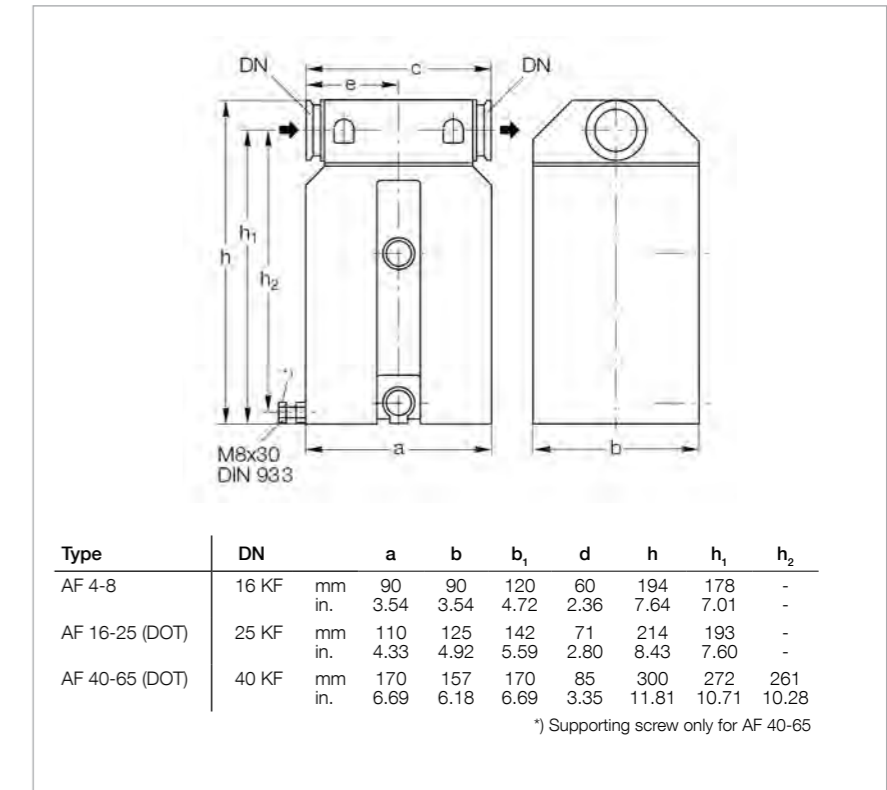

Dimensional drawing for the AF exhaust filters

**Typical Application**

Improvement of oil separating capacity.

**Technical Information**

An exhaust line must be connected in case of hazardous exhaust gases.

Technical Data		AF 4-8	AF 16-25	AF 40-65	AF 16-25 DOT	AF 40-65 DOT
Connection to pump	TRIVAC	D 4/8 B	D 16/25 B/BCS	D 40/65 B/BCS	D 16/25 B-DOT	D 40 B-DOT
Max. capacity for condensate, approx:	l (qt)	0.4	0.5	1.0	-	-
Weight	kg (lbs)	1.9	3.2	6.5	-	-

Ordering Information		AF 4-8	AF 16-25	AF 40-65	AF 16-25 DOT	AF 40-65 DOT
		Part No.	Part No.	Part No.	Part No.	Part No.
Exhaust filter		<b>189 06</b>	<b>189 11</b>	<b>189 16</b>	<b>124 16</b>	<b>101 15</b>
Replacement filter element						
FE 4-8		<b>189 71</b>	-	-	-	-
FE 16-25		-	<b>189 72</b>	-	-	-
FE 40-65		-	-	<b>189 73</b>	-	-
FE 16-25 DOT		-	-	-	<b>E 200 10 304</b>	-
FE 40-65 DOT		-	-	-	-	<b>E200 39 840 <sup>1)</sup></b>
Oil drain tap M 16 x 1.5 (vacuum-tight)		<b>190 90</b>	<b>190 90</b>	<b>190 90</b>	-	-

<sup>1)</sup> 2 pieces are required

## Exhaust Filters with Lubricant Return ARP 4-8 and AR 4-8 to AR 40-65



AR 4-8 exhaust filter with lubricant return



ARP 4-8 exhaust filter with lubricant return

This combination of an exhaust filter with a float-controlled valve considerably extends the maintenance intervals for the TRIVAC pumps.

### Advantages to the User

- Filtering the exhaust air of entrained lubricant particles
- Lubricant return with the aid of a float-controlled valve back into the intake port
- No operating costs caused by lost lubricant
- Hardly any oil consumption
- Standard filter element
- Built-in over-pressure relief valve
- Resists solvents
- All seals made of FPM (FKM)
- Easy change of the return port for horizontal or vertical connection

### Typical Application

Extending the maintenance intervals.

### Supplied Equipment

Intermediate flange, connecting lines with hollow screws, required gaskets as well as mounting screws for the intake flange.

### Technical Information

The AR is connected to the exhaust port of the TRIVAC B, the return line is connected at the intermediate flange under the intake port.

Type	DN	a	b <sub>1</sub>	b <sub>2</sub>	c	e	f	g	h	h <sub>1</sub>	h <sub>2</sub>
AF 4-8	16 KF	mm 45 in. 1.77	90 3.54	136 5.35	120 4.72	60 2.36	100 3.94	113 4.37	194 7.64	179 7.05	167 6.57
AF 16-25	25 KF	mm 55 in. 2.17	125 4.92	167 6.57	142 5.59	71 2.80	120 4.72	-	214 8.43	194 7.64	182 7.17
AF 40-65	40 KF	mm 70 in. 2.76	156 6.14	-	170 6.69	85 3.35	152 5.98	195 7.68	300 11.8	271 10.7	261 10.3

<sup>1)</sup> Supporting screw only for AF 40-65

Dimensional drawing for the AR exhaust filters with lubricant return (dimensions for the ARP exhaust filter with lubricant return upon request)

Technical Data		ARP 4-8	AR 4-8	AR 16-25	AR 40-65
Connection to pump	TRIVAC	D 4/8 B	D 4/8 B	D 16/25 B/BCS	D 40/65 B/BCS
For opening the float-controlled valve required amount of oil					
LEYBONOL MINERAL OIL	cm <sup>3</sup>	-	430 (0.45)	510 (0.54)	760 (0.80)
LEYBONOL LVO 400	cm <sup>3</sup>	-	350 (0.37)	430 (0.45)	700 (0.74)
Verbleibende Schmiermittel-Menge					
LEYBONOL MINERAL OIL	cm <sup>3</sup> (qt)	-	290 (0.31)	340 (0.36)	420 (0.44)
LEYBONOL LVO 400	cm <sup>3</sup> (qt)	-	250 (0.26)	300 (0.32)	390 (0.41)
Weight	kg (lbs)	1.7 (3.8)	3.1 (6.89)	4.7 (10.4)	8.5 (18.7)

Ordering Information		ARP 4-8	AR 4-8	AR 16-25	AR 40-65
		Part No.	Part No.	Part No.	Part No.
Exhaust filter with lubricant return		-	<b>189 20</b>	<b>189 21</b>	<b>189 22</b>
Replacement filter element					
FE 8	<b>ES19080</b>	-	-	-	-
FE 4-8		-	<b>189 71</b>	-	-
FE 16-25		-	-	<b>189 72</b>	-
FE 40-65		-	-	-	<b>189 73</b>

An exhaust line must be connected in case of hazardous exhaust gases. The ARP and AR filters are factory cleaned to such an extent, that they

may be operated either with mineral oil (e.g. LEYBONOL MINERAL OIL) or perfluoropolyether (PFPE) (e.g. LEYBONOL LVO 400).

# Exhaust Filters with Lubricant Return ARS 16-25 and ARS 40-65



ARS 40-65

This combination of an exhaust filter with a float-controlled valve considerably extends the maintenance intervals of the TRIVAC BCS.

The ARS is part of the TRIVAC SYSTEM.

### Advantages to the User

- Lubricant return with the aid of a float-controlled valve back into the intake port
- The intake port may be easily exchanged (either vertical or horizontal orientation)
- No operating costs caused by lost lubricant
- Hardly any oil consumption
- Standard filter element
- All aluminium parts are surface protected
- Built-in over-pressure relief valve
- Resists solvents
- All seals made of FPM (FKM)

### Typical Application

Filtering the exhaust air of entrained lubricant particles.

### Supplied Equipment

Intermediate flange, connecting lines with hollow screws, required gaskets as well as mounting screws for the intake flange.

Wrapped in foil for shipping.

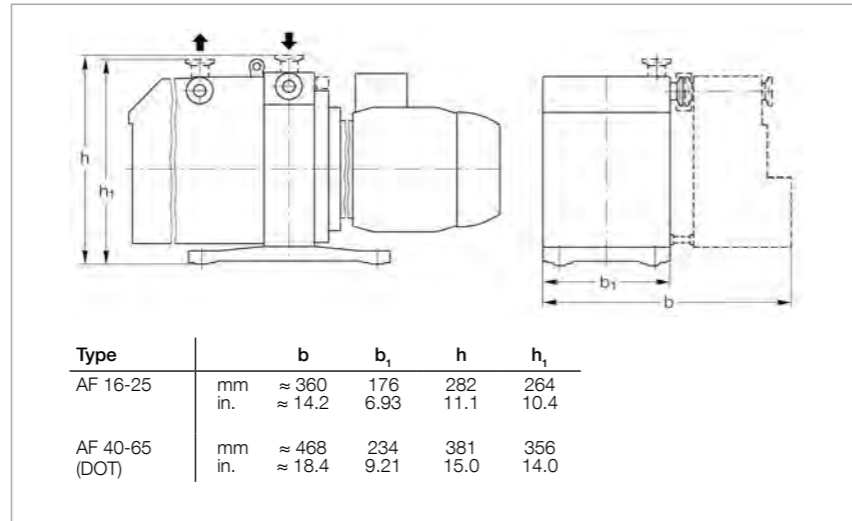

Dimensional drawing for the ARS mounted on a TRIVAC BCS

### Technical Information

An exhaust line must be connected in case of hazardous exhaust gases. The ARS is connected to the exhaust port of the TRIVAC BCS, the return line is connected at the intermediate flange under the intake port.

The ARS is factory cleaned to such an extent, that it may be operated either with mineral oil (e.g. LEYBONOL MINERAL OIL) or perfluoropolyether (PFPE) (e.g. LEYBONOL LVO 400).

### Technical Data

		AR 16-25	AR 40-65
<b>Connection to pump</b>	TRIVAC	D 16/25 B D 16/25 BCS (-PFPE)	D 40/65 B D 40/65 BCS (-PFPE)
<b>Connection flanges</b>	DN	25 KF	40 KF
<b>Amount of oil required for opening the float-controlled valve</b>			
LEYBONOL MINERAL OIL	cm <sup>3</sup> (qt)	510 (0.54)	760 (0.80)
LEYBONOL LVO 400	cm <sup>3</sup> (qt)	340 (0.36)	420 (0.44)
<b>Remaining amount of oil</b>			
LEYBONOL MINERAL OIL	cm <sup>3</sup> (qt)	430 (0.45)	700 (0.74)
LEYBONOL LVO 400	cm <sup>3</sup> (qt)	300 (0.31)	390 (0.41)
<b>Weight with intermediate flange, tubing and filter, without lubricant</b>	kg (lbs)	4.7 (10.4)	8.5 (16.7)

### Ordering Information

	AR 16-25	AR 40-65
<b>Part No.</b>	<b>189 56</b>	<b>189 57</b>
<b>Exhaust filter with lubricant return</b>	<b>189 56</b>	<b>189 57</b>
<b>Replacement filter element</b>		
FE 16-25	<b>189 72</b>	-
FE 40-65	-	<b>189 73</b>

# Oil Drain Tap

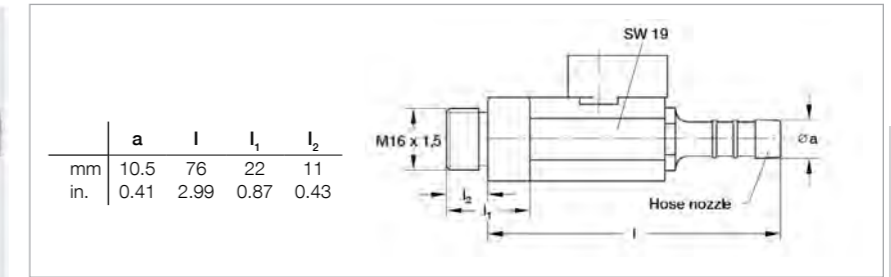

Dimensional drawing for the oil drain tap

This oil drain tap may be screwed into the oil drain when wanting to change the oil in the rotary vane pumps. It is also suited for the condensate separators and exhaust filters of the TRIVAC B series.

### Technical Data

Leak rate	mbar x l/s	Oil Drain Tap
		≤ 10 <sup>-5</sup>

### Ordering Information

	Oil Drain Tap
<b>Part No.</b>	<b>190 90</b>
<b>Oil drain tap</b>	<b>190 90</b>

# Condensate Separators AK 4-8 to AK 40-65



AK 4-8 condensate separator

Separators protect the pump against condensate.

### Advantages to the User

- May be installed without accessories
- May be used either on the intake or the exhaust side
- Independent of the direction of flow
- Condensate level check via inspection glass
- Resists solvents
- All seals made of FPM (FKM)
- Simple to clean
- Easy to use
- Drained via drain screw or drain tap

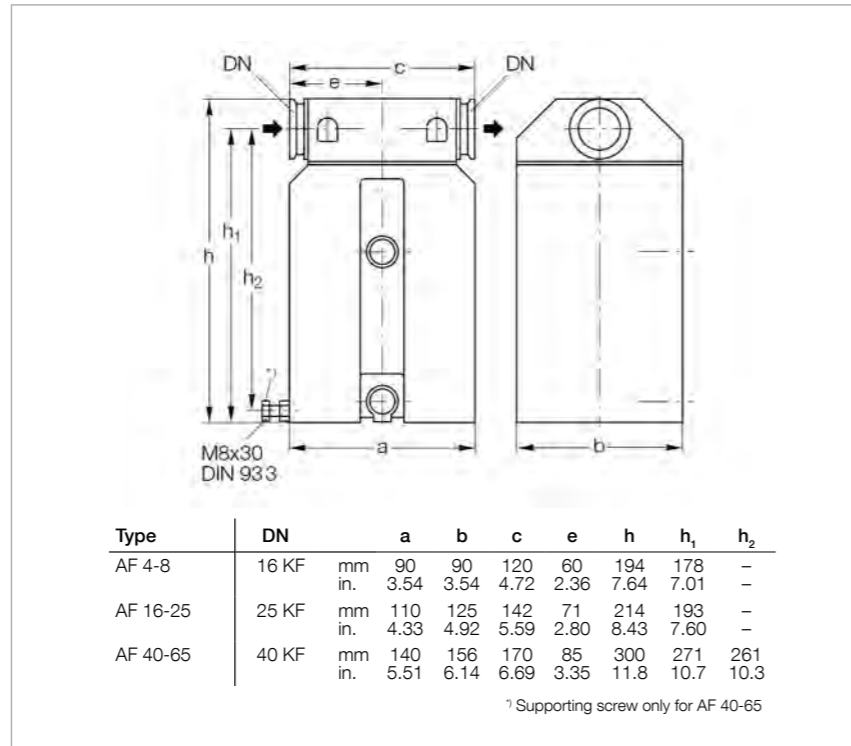

Dimensional drawing for the AK condensate separators

### Typical Application

Prevention of the collection of liquids in the intake line.

### Typical Application

Depending upon the layout and pipe run of an exhaust line, it may be necessary to install a separator to prevent condensate draining back to the pump.

### Technical Data

		AF 4-8	AF 16-25	AF 40-65
Connection to pump	TRIVAC	D 4/8 B	D 16/25 B D 16/25 BCS (-PFPE)	D 40/65 B D 40/65 BCS (-PFPE)
Capacity for condensate	l (qt)	0.66 (0.7)	1.2 (1.3)	3.0 (3.2)
Weight	kg (lbs)	1.7 (3.7)	2.4 (5.3)	5.5 (12.1)

### Ordering Information

	AF 4-8	AF 16-25	AF 40-65
Condensate separator	188 06	188 11	188 16
Oil drain tap M 16 x 1.5 (vacuum-tight)	190 90	190 90	190 90
Adaptor DN 16 KF – hose nozzle DN 7	182 90	-	-

# Dust Filters DN 16 KF to DN 40 KF



Filter housing FH 16 to FH 40 for dust filter insert DF

Dust filters protect the pump against sucked in dust. They are suited for oil sealed and also for dry compressing pumps.

### Advantages to the User

- Easy to disassemble
- Vacuum-tight steel housing
- Easily exchangeable replacement filter
- High filter capacity

### Technical Information

Installing a dust filter in the intake line of the pump throttles its pumping speed at lower intake pressures much more than at higher intake pressures. Throttling reference values are stated in the Technical Data. These must be taken into account when dimensioning the vacuum system.

Since the collection capacity of dust filters is limited, we recommend the two-stage dust filters AS when larger quantities of dust are involved.

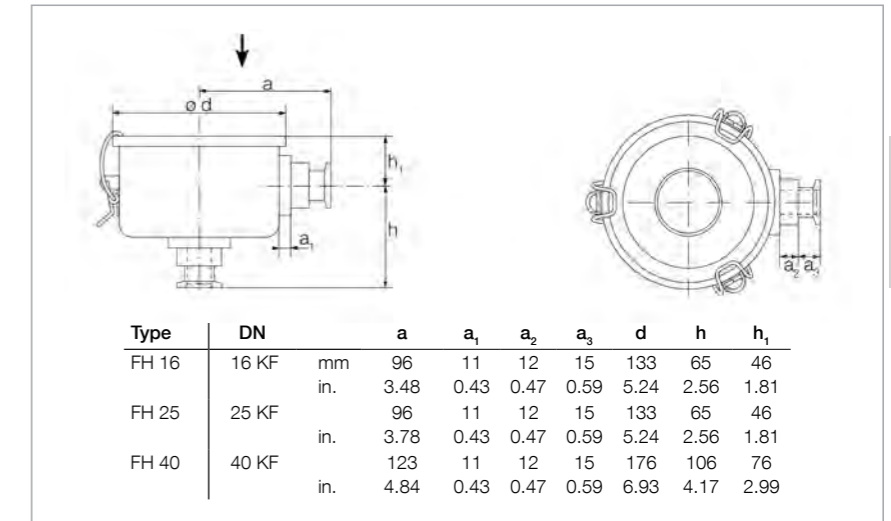

Dimensional drawing for the filter housings FH 16 to FH 40 for dust filter inserts DF

### Technical Data

Use for	TRIVAC	Dust Filter		
		DN 16 KF	DN 25 KF	DN 40 KF
Share of filtered out particles > 5 µm	%	98	98	98
Throttling of pumping speed at 10 mbar (7.5 Torr)	%	3	3	3
at 1 mbar (0.75 Torr)	%	6	6	6
Weight with dust filter insert	kg (lbs)	1.3 (2.9)	1.3 (2.9)	2.3 (5.1)

### Ordering Information

	DN 16 KF	DN 25 KF	DN 40 KF
Dust filter filter housing FH <sup>1)</sup>	140 116T	140 125T	140 140T
dust filter insert DF 16-25	140 117S	140 117S	-
DF 40-65	-	-	140 141S

<sup>1)</sup> The filter housing is supplied without filter cartridge (dust filter insert) since it may also be used in connection with the adsorption trap or dust filter insert

# Adsorption Traps DN 16 KF to DN 40 KF



Filter housing FH 16 to FH 40 for adsorption trap filter inserts RF

Adsorption traps are containers with a stainless steel insert which can be filled with a number of different adsorbents thereby offering a high adsorbing capacity for vapors, water vapor in particular.

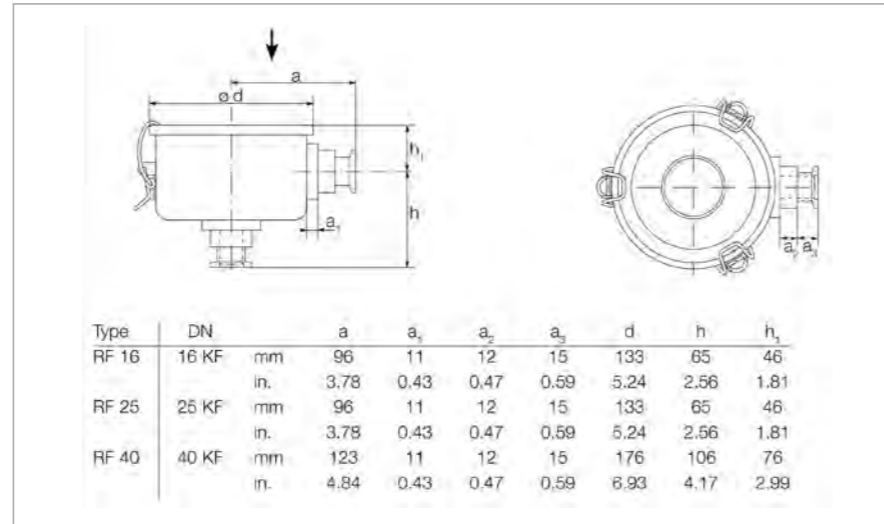

Dimensional drawing for the filter housings FH 16 to FH 40 for adsorption trap filter inserts RF

### Technical Data Adsorption Trap

		DN 16 KF	DN 25 KF	DN 40 KF
--	--	----------	----------	----------

Use for	TRIVAC	D 4/8 B	D 16/25 B	D 40/65 B
<b>Conductance</b>				
at 10 mbar (7.5 Torr) for aluminium oxide	l/s	2	6	14
zeolite	l/s	2	6	12
active charcoal filling	l/s	2	6	16
baffle ring filling	l/s	2	7	18
at 1 mbar (0.75 Torr) for aluminium oxide	l/s	1	4	5
zeolite	l/s	1	6	5
active charcoal filling	l/s	2	6	6
baffle ring filling	l/s	2	6	16
<b>Filling quantity</b>				
aluminium oxide	kg (lbs)	0.3 (0.7)	0.3 (0.7)	1.0 (2.2)
zeolite	kg (lbs)	0.2 (0.4)	0.2 (0.4)	0.7 (1.5)
active charcoal filling	kg (lbs)	0.1 (0.2)	0.1 (0.2)	0.5 (1.1)
baffle ring filling	kg (lbs)	0.1 (0.2)	0.1 (0.2)	0.3 (0.7)
<b>Filling volume</b>	l (qt)	0.3 (0.3)	0.3 (0.3)	1.2 (1.3)
<b>Weight with adsorption trap insert</b>	kg (lbs)	1.3 (2.9)	1.3 (2.9)	2.3 (5.1)

### Ordering Information Adsorption Trap

	DN 16 KF	DN 25 KF	DN 40 KF
--	----------	----------	----------

	Part No.	Part No.	Part No.
Adsorption trap filter housing FH <sup>1)</sup>	140 116T	140 125T	140 140T
adsorption trap filter insert RF 16-25	140 118A	140 118A	-
RF 40-65	-	-	140 142A
Active charcoal, un-dried, 5 kg	178 10	178 10	178 10
Zeolite, 1 kg	854 20	854 20	854 20
Aluminium oxide, 1.2 kg	854 10	854 10	854 10
Baffle ring 15 x 15 x 0.3, 1 liter			
Stainless steel 1.4301	390 26 126	390 26 126	390 26 126

<sup>1)</sup> The filter housing is supplied without filter cartridge (dust filter insert) since it may also be used in connection with the adsorption trap or dust filter insert

### Advantages to the User

- Vacuum-tight steel housing
- Stainless steel, degassable up to 300 °C (572 °F)
- Different adsorbents and separating elements can be used
- Quick to replace
- Easy to disassemble

### Technical Information

The adsorption traps have been developed specially for use in connection with oil sealed pumps. They are capable of retaining oil vapors discharged from forevacuum pumps and are at the same time in the position to separate vapors (water vapor) coming from the side of the process. Through the use of adsorption traps and a suitable adsorbent, a vacuum free of hydrocarbons can be produced. The stainless steel inserts with the corresponding adsorbent can be heated in a drying cabinet at 300 °C (572 °F) for regeneration. Depending on the type of adsorbent and operating pressure, the pumping speed of the pumps is reduced.

As to any questions relating to the selection of a suitable adsorbent, please consult us.

# Cold Trap TK 4-8



TK 4-8 cold trap

The cold trap protects the pump against damaging vapors.

### Advantages to the User

- Rugged and implosion resistant
- May be fitted directly on the flange of the pump
- Safe draining of the condensate without problems
- Casing made of corrosion resistant stainless steel
- Simple filling with refrigerant (liquid nitrogen (LN<sub>2</sub>) or a mixture of acetone and carbon di-oxide ice)

### Technical Applications

- Prevention of oil from backstreaming into the vacuum system when operating at ultimate pressure
- Freezing of gases and vapors in the laboratory

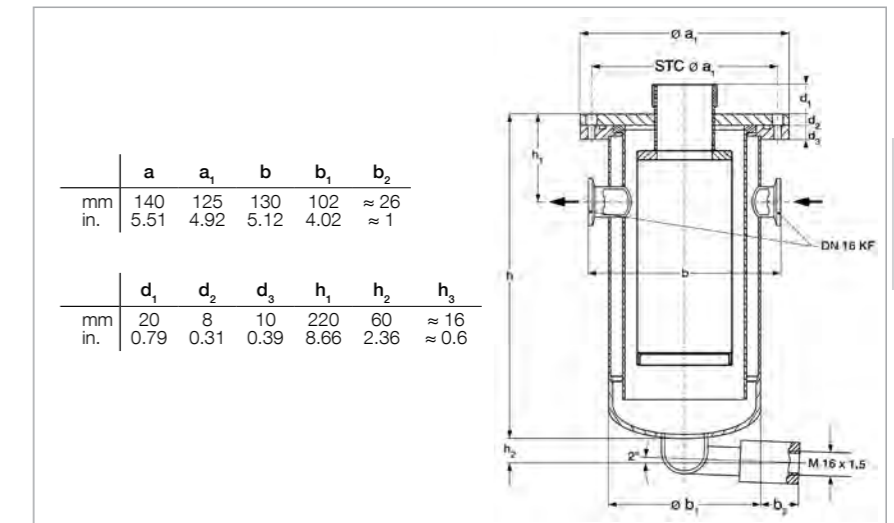

Dimensional drawing for the TK 4-8 cold trap

### Technical Data TK 4-8

Connection to pump	TRIVAC	D 2,5 E, D 4/8 B
Capacity for refrigerant, approx.	l (qt)	0.4 (0.42)
Connections	DN	16 KF
Weight	kg (lbs)	4 (8.8)

### Ordering Information TK 4-8

	Part No.
Cold trap	188 20
Drain tap for the intake side, vacuum-tight	190 90
Elbow (1x)	184 36
Centering ring aluminium/NBR (2x)	183 26
stainless steel/FPM (FKM) (2x)	883 46
Clamping ring (2x)	183 41

# Dust Separators AS 8-16 and AS 30-60



AS 30-60 dust separator

Dust separators protect pumps against contamination and damage by sucked-in dust.

### Advantages to the User

- Dust separators for large quantities of dust
- Two-stage, thus hardly any throttling
- Cyclone (for coarse dust) and wet filter (for fine dust)

### Technical Applications

Separation of coarse and medium size dust starting at a grain size of 2 µm.

### Technical Applications

Installing a dust filter in the intake line of the pump will throttle its pumping speed at low intake pressures more than at higher intake pressures. This must be taken into account when designing a vacuum system.

Even when large quantities of dust are deposited, the throttling effect will hardly increase.

### Supplied Equipment

Blanked off drain port.

### Technical Data

		AS 8-16		AS 30-60		
Connection to pump	TRIVAC	D 16 B	D 25 B	D 40 B	D 65 B	
Throttling of the pumping speed	at 1 mbar (0.75 Torr) intake pressure, approx.	%	10	15	8	16
	at 10 mbar (7.5 Torr) intake pressure, approx.	%	5	7	4	9
Connection to pump	l (qt)	0.6 (0.63)	0.6 (0.63)	2.0 (2.11)	2.0 (2.11)	
Capacity for resin vapors or similar	kg (lbs)	-	-	-	-	
Impact ring filling	l (qt)	0.5 (0.53)	0.5 (0.53)	3.5 (3.7)	3.5 (3.7)	
Active charcoal filling	kg (lbs)	-	-	-	-	
Weight	kg (lbs)	4.5 (9.9)	4.5 (9.9)	18.4 (40.6)	18.4 (40.6)	

### Ordering Information

	AS 8-16	AS 30-60
Dust separator	-	<b>186 16</b>
Molecular filter	-	-
Replacement filter insert	-	<b>178 43</b>

Type	DN	a	a <sub>1</sub>	c	ød	ød <sub>1</sub>	h	h <sub>1</sub>	h <sub>2</sub>	k	
AS 8-16	25 KF	mm	181	100	43	133	162	247	150	37	
		in.	7.13	3.94	1.69	5.24	6.38	9.72	5.91	1.46	
AS 30-60	40 KF	mm	310	190	70	205	234	530	395	190	75
		in.	12.2	7.48	2.76	8.07	9.12	20.9	15.6	7.48	2.95

Dimensional drawing for the AS dust separators

# Mechanical Oil Filters OF 4-25 and OF 40-65 Chemical Oil Filters CF 4-25 and CF 40-65



OF 4-25 mechanical oil filter

Since there is a pressure-lubrication system with an oil pump in every TRIVAC B, it is possible to connect main flow oil filters.

These filters are available either for mechanical filtering (OF types) or combined chemical/mechanical filtering (CF types).

Type	a	b	h	l	
OF 4-25	mm	100	200	150	-
	in.	4.0	7.87	5.91	-
CF 4-25	mm	100	315	160	-
	in.	4.0	12.4	6.30	-
OF 40-65	mm	135	-	239	296
	in.	5.31	-	9.41	11.7
CF 40-65	mm	135	-	307	296
	in.	5.31	-	12.1	11.7

Dimensional drawings for the OF mechanical oil filters and CF chemical oil filters

### Advantages to the User

- Main flow oil filter
- Longer service life for the oil depending on the type of application
- Can be installed without problems to the TRIVAC B
- Hose connections are not required
- Easily interchangeable filters
- Only a small amount of oil needs to be added when changing the filters
- Expansion of the range of applications in case of special requirements

- Same casing for OF and CF types
- Greater reliability by standard maintenance indicator
- Built-in bypass valve
- Owing to the highly effective adsorbent for polar substances, an up to ten-fold adsorption effect is attained over normal bleaching earth (CF)
- Prevents mechanical damage to the pump

### Typical Application

Separation of fine particles from the pump's oil (sizes between 5 and 10 µm (OF)).

**Technical Data**                      **OF 4-25**                      **CF 4-25**                      **OF 40-65**                      **CF 40-65**

Connection to pump	TRIVAC	D 4/8 B, D 16/25 B	D 4/8 B, D 16/25 B	D 40/65 B	D 40/65 B
Nominal throughput	l/h	900	900	2000	2000
Separation mechanical oil filter	µm	5 to 10	5 to 10	5 to 10	5 to 10
chemical oil filter	µm	to 3	to 3	to 3	to 3
Permissible operating pressure	bar (psig)	2.5 (21.7)	2.5 (21.7)	2.5 (21.7)	2.5 (21.7)
Opening pressure non-return valve	bar (psig)	0.12 (1.7)	0.12 (1.7)	0.12 (1.7)	0.12 (1.7)
bypass valve	bar (psig)	2.5 ±0.3 (21.7 ±4.3)	2.5 ±0.3 (21.7 ±4.3)	2.5 ±0.3 (21.7 ±4.3)	2.5 ±0.3 (21.7 ±4.3)
Topping up amount during first time installation	l (qt)	1.0 (1.1)	1.0 (1.1)	2.5 (2.6)	2.5 (2.6)
filter exchange	l (qt)	1.0 (1.1)	1.0 (1.1)	2.0 (2.1)	2.0 (2.1)
Weight, ready for operation, dry	kg (lbs)	4 (8.8)	4 (8.8)	10 (22.1)	10 (22.1)

**Ordering Information**                      **OF 4-25**                      **CF 4-25**                      **OF 40-65**                      **CF 40-65**

	Part No.	Part No.	Part No.	Part No.
Mechanical oil filter	<b>101 91</b>	-	<b>101 92</b>	-
Chemical oil filter	-	<b>101 96</b>	-	<b>101 97</b>
WF 4-25 interchangeable filter, paper, 0.5 l (0.5 qt)	<b>189 91</b>	-	-	-
WF 40-65 interchangeable filter, paper, 0.75 l (0.8 qt)	-	-	<b>189 92 <sup>1)</sup></b>	<b>189 92 <sup>1)</sup></b>
WF Alu 4-65 interchangeable filter, paper and Al <sub>2</sub> O <sub>3</sub> , 1 l (1.1 qt)	-	<b>189 96</b>	-	<b>189 96 <sup>1)</sup></b>

<sup>1)</sup> 2 pieces are required

# Chemical Filters with Safety Isolation Valve CFS 16-25 and CFS 40-65



CFS 40-65

The CFS chemical filters with safety isolation valve are main flow oil filters for the TRIVAC B and BCS pumps.

The CFS is part of the TRIVAC SYSTEM.

**Advantages to the User**

- The CFS is included in the main lubricant flow
- Rapid filter exchange
  - the pump may continue to operate while changing the filters
- Visual indication of the filter's condition through a maintenance indicator
- Aluminium component with isolation valve for one or two interchangeable filters
- All aluminium parts are surface protected
- May be operated with different interchangeable filters
- Over-pressure relief valve in the interchangeable filters
- Prepared for connection of a differential pressure switch and an oil pressure switch
- May also be used on the TRIVAC B pumps

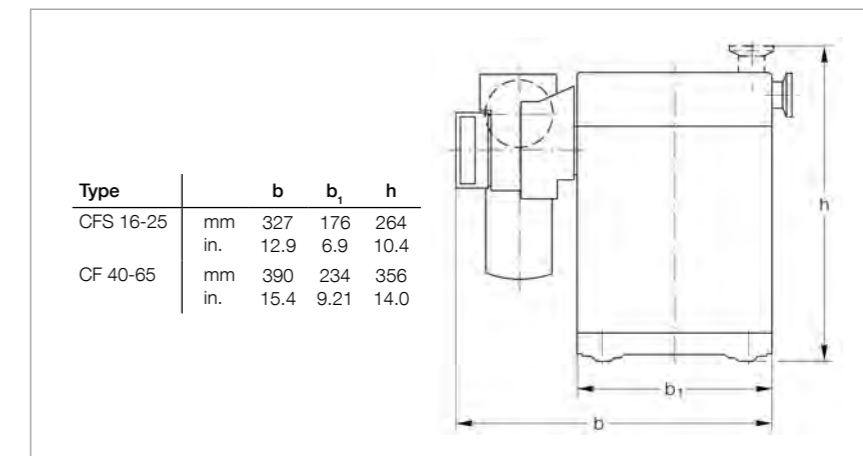

Dimensional drawing for the CFS (mounted on a TRIVAC BCS)

**Technical Information**

The CFS is cleaned in the factory to such an extent, that it may be operated either with mineral oil (e.g. LEYBONOL MINERAL OIL) or perfluoropolyether (PFPE, e.g. LEYBONOL LVO 400)..

**Supplied Equipment**

All gaskets and mounting parts required for installation.

Aluminium particle filters (WF Alu-Part) sealed for shipping are included separately.

**Technical Data**

		<b>CFS 16-25</b>	<b>CFS 40-65</b>
Connection to pump	TRIVAC	D 16/25 B D 16/25 BCS (-PFPE)	D 40/65 B D 40/65 BCS (-PFPE)
Nominal throughput	l/h	900	2000
Permissible operating pressure	bar (psig)	2.5 (21.7)	2.5 (21.7)
Opening pressure Non-return valve	bar (psid)	2.5 (21.7)	2.5 (21.7)
Bypass valve	bar (psid)	2.5 ±0.3 (21.7 ±4.3)	2.5 ±0.3 (21.7 ±4.3)
Filter medium		Al <sub>2</sub> O <sub>3</sub>	Al <sub>2</sub> O <sub>3</sub>
Lubricant filling when using WF Alu-Part	l (qt)	1.4 (1.5)	3.3 (3.5)
Weight, ready for operation, dry	kg (lbs)	7.0 (15.4)	15.5 (34.1)

**Ordering Information**

	Part No.	Part No.
Chemical filter with safety isolation valve	<b>101 76</b>	<b>101 77</b>
WF Alu-Part combination filter, paper and Al <sub>2</sub> O <sub>3</sub> , 1.6 l (1.7 qt)	<b>189 99</b>	<b>189 99 <sup>1)</sup></b>
WFG particle filter, paper with support mesh, 1 l (1.1 qt)	<b>189 90</b>	<b>189 90 <sup>1)</sup></b>

<sup>1)</sup> 2 pieces are required

# Inert Gas System IGS 16-25 and IGS 40-65



IGS

This accessory, which is controlled via solenoid valves, permits the controlled admission of special gases into the TRIVAC BCS.

The IGS is part of the TRIVAC SYSTEM.

### Advantages to the User

- Ready for connection to an inert gas supply
- Solenoid valve for reduced gas ballast
- Solenoid valve for purging the oil box
- Float throughput gauge with throttling valve adjustable from 200 to 700 l/h
- The flowing quantity can be read directly
- System protection by a non-return valve (requires a reservoir pressure of at least 3 bar (29 psi, gauge)) – this reliably prevents the reservoir vessel from being evacuated
- Connects directly on to the TRIVAC BCS

### Typical Applications

- Reduction of the contamination levels in the lubricant
- Reduction in the dwell time of volatile substances within the pump

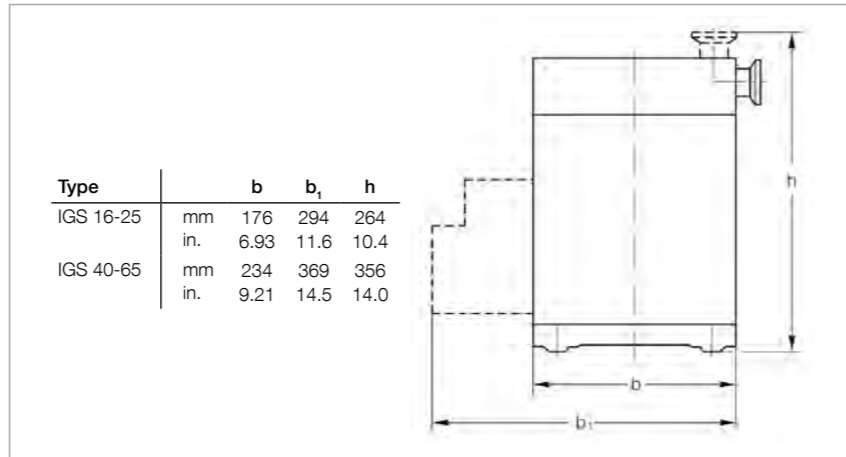

Dimensional drawing for the IGS (mounted on a TRIVAC BCS)

Type		b	b <sub>1</sub>	h
IGS 16-25	mm	176	294	264
	in.	6.93	11.6	10.4
IGS 40-65	mm	234	369	356
	in.	9.21	14.5	14.0

### Technical Information

The amount of inert gas ballast is restricted by a nozzle to 200 l/h. Larger quantities are used for purging.

### Supplied Equipment

Solenoid valves with connection cables and plugs, the required connecting pieces, mounting screws and cover panel.

### Technical Data

		IGS 16-25	IGS 40-65
Connection to pump	TRIVAC	D 16/25 BCS (-PFPE)	D 40/65 BCS (-PFPE)
Min. amount of admitted gas at a reservoir pressure of 3.0 bar (29 psig)	l/h	200	200
Max. amount of admitted gas at a reservoir pressure of 6.0 bar (72.5 psig)	l/h	1450	1450
Supply voltage for the solenoid valves	V DC	24	24
Power consumption	W	10	10
Weight	kg (lbs)	1.0 (2.2)	1.4 (3.1)
Connection thread	G (BPS)	1/8"	1/8"

### Ordering Information

	IGS 16-25	IGS 40-65
	<b>Part No.</b>	<b>Part No.</b>
Inert gas system	<b>161 76</b>	-
Inert gas system, UL conform	-	<b>161 68V</b>

# Limit Switch System LSS 16-25 and LSS 40-65



LSS

This accessory consists of a package of limit switches. It is used to monitor system functions.

The LSS is part of the TRIVAC SYSTEM.

The package of limit switches includes:

- Differential pressure switch to monitor the CFS
- Oil pressure switch to monitor the operating pressure
- Flow switch to monitor the inert gas flow
- Pressure switch to monitor the pressure in the oil box of the pump
- Connection cable and plug for the temperature switch used for temperature monitoring
- Float switch with housing to monitor the oil level

### Advantages to the User

- Errors are indicated well in advance so that it will in most cases be possible to complete the process for the running batch
- The switching action is independent of the optical displays (for optimum reliability)
- The temperature switch is already present in the TRIVAC BCS

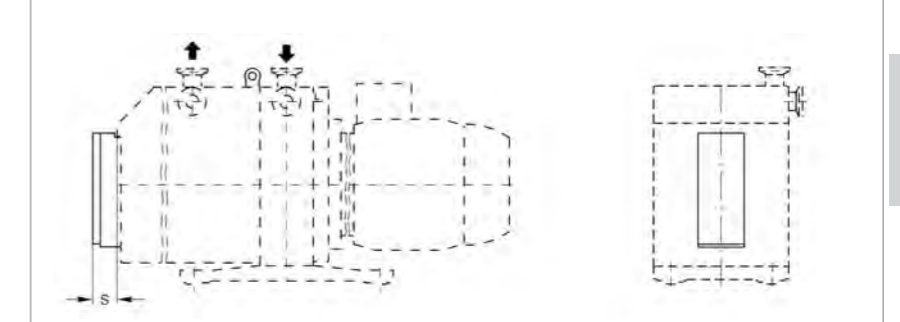

Type		S
LSS 16-25	mm	55
	in.	2.17
LSS 40-65	mm	51
	in.	2.01

Dimensional drawing for the LSS (mounted on a TRIVAC BCS)

### Technical Information

Changing the status in case operating conditions arise which are not permissible.

### Supplied Equipment

Fully wired-up switches with plugs as well as all required gaskets and mounting parts.

### Technical Data

		LSS 16-25	LSS 40-65
Connection to pump	TRIVAC	D 16/25 BCS (-PFPE)	D 40/65 BCS (-PFPE)
Operating voltage	V DC	24	24
Switching capacity	W / A	10.0 / 0.4	10.0 / 0.4
Type of protection	IP	54	54
Weight, approx.	kg (lbs)	2.5 (5.5)	2.5 (5.5)

### Ordering Information

	LSS 16-25	LSS 40-65
	<b>Part No.</b>	<b>Part No.</b>
Limit switch system	<b>161 06</b>	<b>161 07</b>

# Roots Pump Adaptor

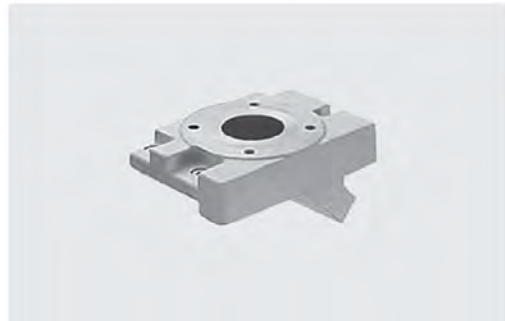

Roots pump adaptor

The Roots pump adaptor allows the direct installation of a Roots pump on a TRIVAC D 40/65 B/BCS.

### Advantages to the User

- Compact and space-saving
- Short and direct connection between the pumps
- Minimal conductance loss
- Easy installation

### Typical Application

Simple assembly of a small pump system.

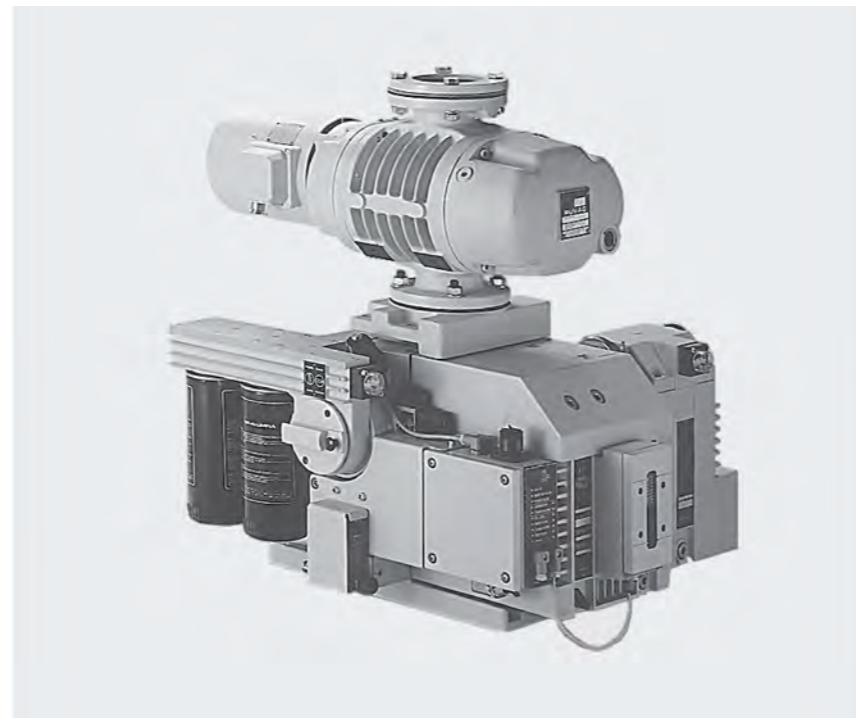

Pump system consisting of a TRIVAC D 65 BCS and a RUVAC WS 251

### Technical Data

		Roots Pump Adaptor
Connection to pump	TRIVAC	D 40/65 B/BCS (-PFPE) and RUVAC WA/WAU/WS/WSU 251
Weight	kg (lbs)	11.5 (25.4)

### Ordering Information

		Roots Pump Adaptor
		Part No.
Roots pump adaptor		168 30

# Only available for purchase in North and South America

## SE Smoke Eliminator



SE smoke eliminator

The Leybold SE smoke eliminator can be utilized on all TRIVAC B rotary vane vacuum pumps where pump fluid loss at the exhaust port must be eliminated. These filters consist of a replaceable two-stage coalescing element mounted in a steel housing. For maintenance purposes, the top of the housing can be removed by loosening a single bolt. The filter assembly attaches to the exhaust port of the TRIVAC pump by means of a KF flange. Since three models are available, an SE smoke eliminator is available for each TRIVAC pump model.

### Advantages to the User

- Two stage design
- Three sizes for all TRIVAC models
- KF flanges

### Applications

When any oil sealed mechanical vacuum pump is used to pump a fixed volume from atmospheric pressure to some lower pressure or when a dynamic gas flow from a process stream is pumped, some mechanical pump fluid loss will occur at the exhaust of the pump. The more often a fixed volume is cycled from atmospheric pressure to a lower pressure or the longer a pump operates at a relatively high inlet pressure in a dynamic flow condition, the greater will be the fluid loss at the exhaust port of the pump.

By utilizing a coalescing exhaust filter for these applications, the fluid and exhaust gases are separated, and in the case of the SE smoke eliminator, the coalesced fluid is allowed to drain back into the pump fluid reservoir. Annoying oil fog to the atmosphere is thus eliminated.

Eventually, after about a year's normal operation, the coalescing element will become totally saturated and oil fog will be apparent when high inlet pressures

are prevailing. The low cost coalescing element can be easily replaced.

**Note:** For applications where toxic, corrosive, radioactive or precious gases are pumped, we highly recommend the use of our AF coalescing exhaust filters instead of the SE smoke eliminator. The AF is an in-line type coalescing filter and much more suitable for these applications.

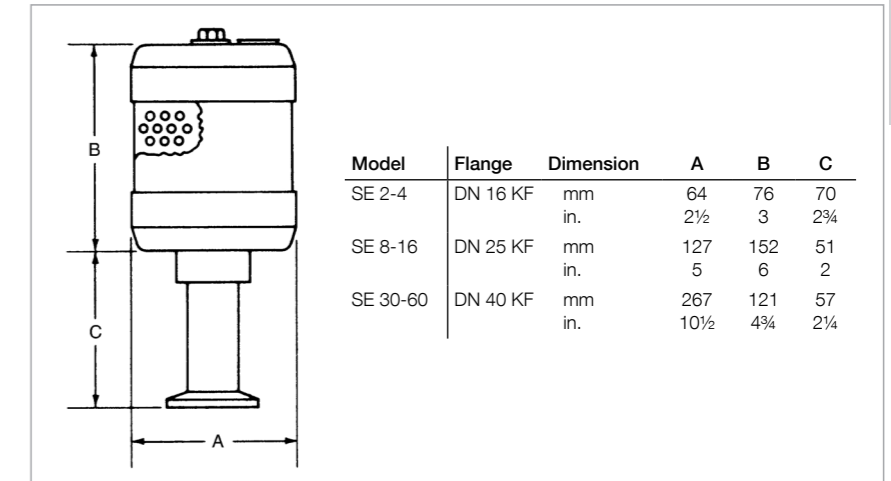

Dimensional drawing for the SE

### Technical Data

		SE 2-4	SE 8-16	SE 30-60
Connection to pump	TRIVAC	D 4/8 B	D 16/25 B	D 40/65 B

### Ordering Information

	SE 2-4	SE 8-16	SE 30-60
Smoke eliminator	99 171 125	99 171 126	99 171 127
Replacement element			
RE 2-4	99 171 128	-	-
RE 8-16	-	99 171 129	-
RE 30-60	-	-	99 171 130

# General Accessories

## Flange Components, Valves

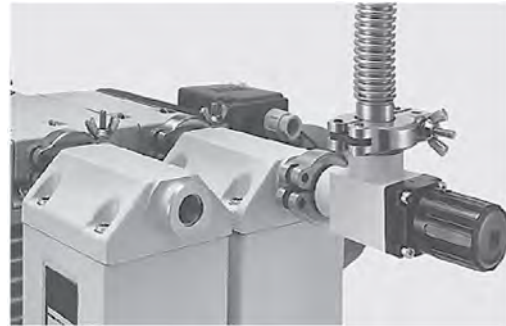

Our range of flange components and valves is described in detail in the Catalog Parts “Flanges and Fittings” and “Valves”.

Given in the following are only some components which you might find particularly useful when planning your system.

### Isolation Valve

- The pump is allowed to warm up with the intake line isolated
- The pump may continue to operate in the energy-saving and environmentally compatible ultimate pressure mode when the vacuum chamber is vented briefly
- The pump may be left on after completion of the process so as to regenerate the oil

### Branch (Cross)

Installing a cross in the intake line permits the connection of a vacuum gauge and a venting valve.

### Flange Connections

Each flange connection requires one each centering and clamping ring.

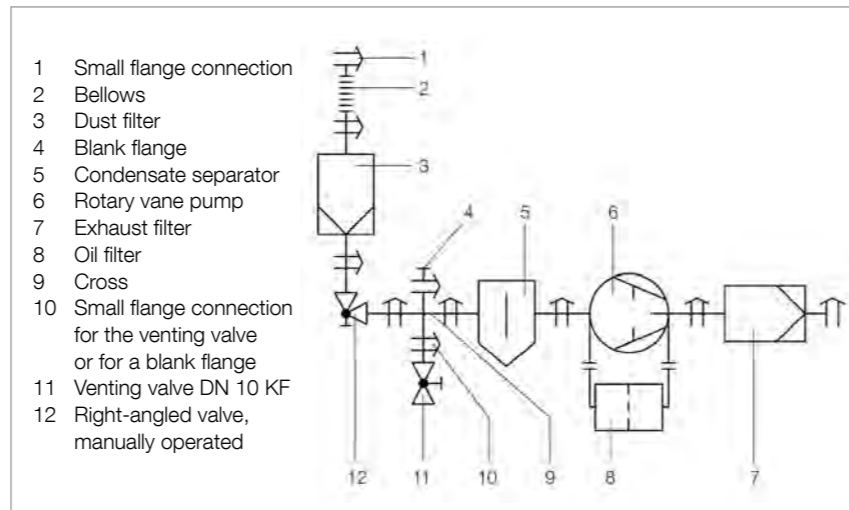

Example of connecting a pump with accessories

### Ordering Information

**DN 16 KF    DN 25 KF    DN 40 KF**

	Part No.	Part No.	Part No.
<b>Small flange connection</b>			
Clamping ring	183 41	183 42	183 43
Centering ring, aluminium/CR	183 26	183 27	183 28
Centering ring, stainless steel/FPM (FKM)	883 46	883 47	883 48
<b>Bellows</b>	872 41	872 43	872 45
<b>Right-angled valve, manually operated</b>			
Aluminium casing	215 375	215 376	215 377
Stainless steel casing	215 383	215 385	215 386
<b>Blank flange for (reducing) cross</b>			
Aluminium	184 46	184 47	184 48
Stainless steel	884 36	884 41	884 41
<b>Reducing cross (to DN 10 KF)</b>			
Stainless steel	-	884 92	884 92
<b>Cross DN 16 KF</b>			
Aluminium	184 71	-	-
Stainless steel	884 85	-	-
<b>Small flange connection for venting valve or blank flange</b>			
Clamping ring	183 41	183 41	183 41
(Adaptor) centering ring, aluminium/NBR	183 56	183 57	183 57
(Adaptor) centering ring, stainless steel/FPM (FKM)	883 56	883 57	883 57
<b>Venting valve DN 10 KF</b>			
Aluminium	173 24	173 24	173 24
Stainless steel	173 37	173 37	173 37

# Miscellaneous

## Services

### On-site Replacement of the Dynamic Seals (with LEYBONOL MINERAL OIL)

The on-site replacement of the dynamic seals includes the following:  
Partial disassembly of the pump, replacement of the complete shaft seal, mounting of the pump including new gaskets and standard oil LEYBONOL MINERAL OIL, electrical safety test, test run including check of the attained ultimate pressure levels.

### Ordering Information

### On-site Replacement of the Dynamic Seals (with LEYBONOL MINERAL OIL)

	Part No.
<b>For pump</b>	
TRIVAC D 4 B	AS 1130 F
TRIVAC D 8 B	AS 1130 F
TRIVAC D 16/25 B	AS 1129 F
TRIVAC D 40/65 B	AS 1128 F
TRIVAC D 40/65 BCS	AS 1137 F

### Small On-site Maintenance (with LEYBONOL MINERAL OIL)

The small on-site maintenance includes the following:  
Oil change (standard LEYBONOL MINERAL OIL), filter replacement, visual inspection of the subassemblies, cleaning of the pump module and the oil box, electrical safety test, test run including check of the attained ultimate pressure levels.

### Ordering Information

### On-site Maintenance (with LEYBONOL MINERAL OIL)

	Part No.
<b>For pump</b>	
TRIVAC D 4 B	AS 1160 F
TRIVAC D 8 B	AS 1159 F
TRIVAC D 16 B + BCS with standard gaskets	AS 1158 F
TRIVAC D 25 B + BCS with standard gaskets	AS 1157 F
TRIVAC D 40/65 B + BCS with standard gaskets	AS 1156 F

**Comprehensive On-site Maintenance (with LEYBONOL MINERAL OIL) <sup>1)</sup>**

Comprehensive on-site maintenance includes the following:

Disassembly of the pump, cleaning of all individual components, replacement of all wearing parts, mounting of the pump including new gaskets and standard oil LEYBONOL MINERAL OIL, electrical safety test, test run including check of the attained ultimate pressure levels.

**Ordering Information**

**Comprehensive On-site Maintenance (with LEYBONOL MINERAL OIL) <sup>1)</sup>**

	Part No.
For pump	
TRIVAC D 4 B	AS 1125 F
TRIVAC D 8 B	AS 1124 F
TRIVAC D 16 B	AS 1121 F
TRIVAC D 25 B	AS 1120 F
TRIVAC D 40 B	AS 1117 F
TRIVAC D 65 B	AS 1116 F
TRIVAC D 40 BCS with Viton gaskets	AS 1136 F
TRIVAC D 65 BCS with Viton gaskets	AS 1135 F
TRIVAC D 40 BCS with standard gaskets	AS 1132 F
TRIVAC D 65 BCS with standard gaskets	AS 1131 F

**<sup>1)</sup> Notes on our on-site after sales service**

The listed services include the costs for material and working hours on-site for standard TRIVAC pumps. Services for pump variants upon request.

Transportation and travelling expenses are invoiced at cost. All services refer to the repair of freely accessible and not contaminated vacuum components.

**As to services for TRIVAC B-DOT, TRIVAC B-Ex please ask us for a quotation.**

**Complete Refurbishing at the Service Center (with LEYBONOL MINERAL OIL)**

Complete refurbishing at the service center includes the following:

Disassembly of the pump, visual inspection of the subassemblies, replacement of all wearing parts, machined reworking of the pump module, mounting of the pump including new gaskets and standard oil LEYBONOL MINERAL OIL, electrical safety test, test run including check of the attained ultimate pressure levels.

**Ordering Information**

**Complete Refurbishing at the Service Center (with LEYBONOL MINERAL OIL)**

	Part No.
For pump	
TRIVAC D 4 B	AS 1125
TRIVAC D 8 B	AS 1124
TRIVAC D 16 B	AS 1121
TRIVAC D 25 B	AS 1120
TRIVAC D 40 B	AS 1117
TRIVAC D 65 B	AS 1116
TRIVAC D 40 BCS with Viton gaskets	AS 1136
TRIVAC D 65 BCS with Viton gaskets	AS 1135
TRIVAC D 40 BCS with standard gaskets	AS 1132
TRIVAC D 65 BCS with standard gaskets	AS 1131

**Complete Refurbishing with Decontamination at the Service Center (with LEYBONOL MINERAL OIL)**

Complete refurbishing with decontamination at the service center includes the following:

Disassembly of the pump, decontamination of the individual components, visual inspection of the individual subassemblies, replacement of all wearing parts, machined reworking of the pump module, mounting of the pump including new gaskets and standard oil LEYBONOL MINERAL OIL, electrical safety test, test run including check of the attained ultimate pressure levels.

**Ordering Information**

**Complete Refurbishing with Decontamination at the Service Center (with LEYBONOL MINERAL OIL)**

	Part No.
For pump	
TRIVAC D 4 B	AS 1125
TRIVAC D 8 B	AS 1124
TRIVAC D 16 B	AS 1121
TRIVAC D 25 B	AS 1120
TRIVAC D 40 B	AS 1117
TRIVAC D 65 B	AS 1116
TRIVAC D 40 BCS with Viton gaskets	AS 1136
TRIVAC D 65 BCS with Viton gaskets	AS 1135
TRIVAC D 40 BCS with standard gaskets	AS 1132
TRIVAC D 65 BCS with standard gaskets	AS 1131

# Only available for purchase in North and South America

## 60 Hz Curves

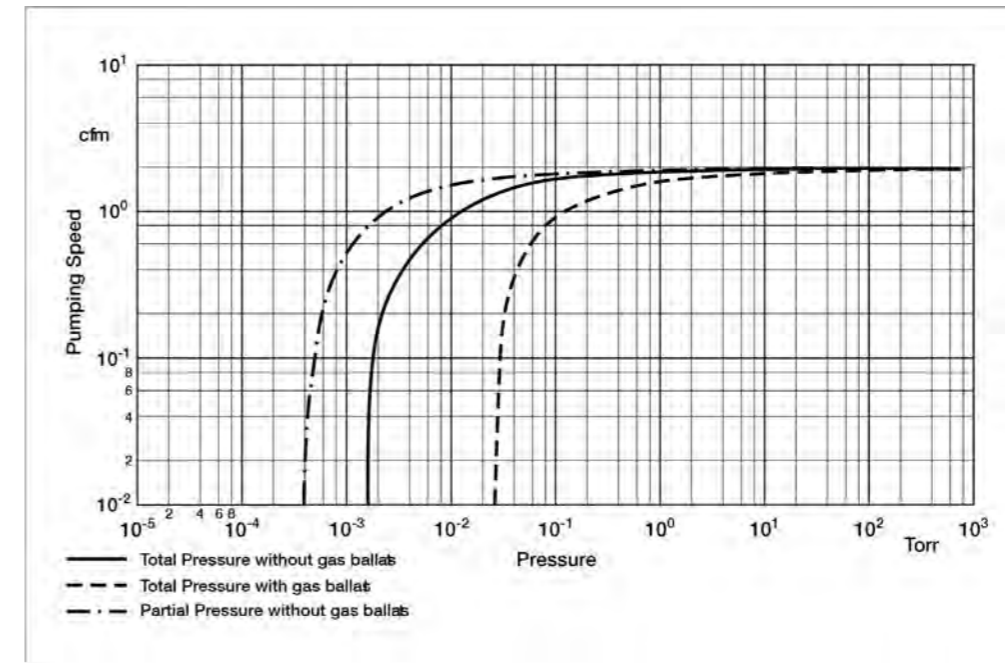

Pumping speed characteristics for the TRIVAC D 2,5 E at 60 Hz

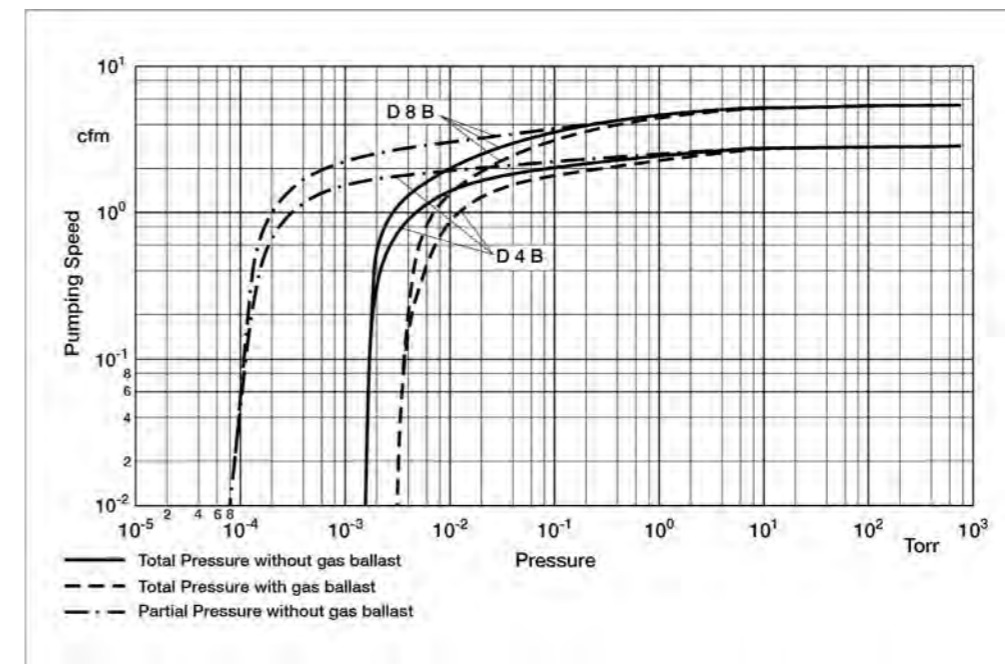

Pumping speed characteristics for the TRIVAC D 4 B and D 8 B at 60 Hz

# Only available for purchase in North and South America

## 60 Hz Curves

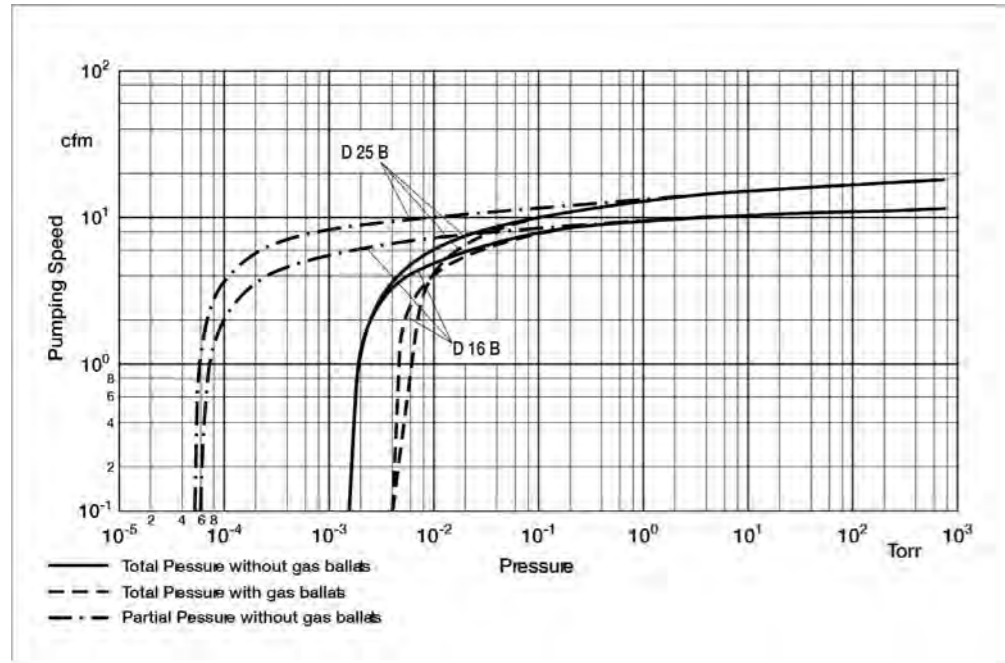

Pumping speed characteristics for the TRIVAC D 16 B/BCS and D 25 B/BCS at 60 Hz

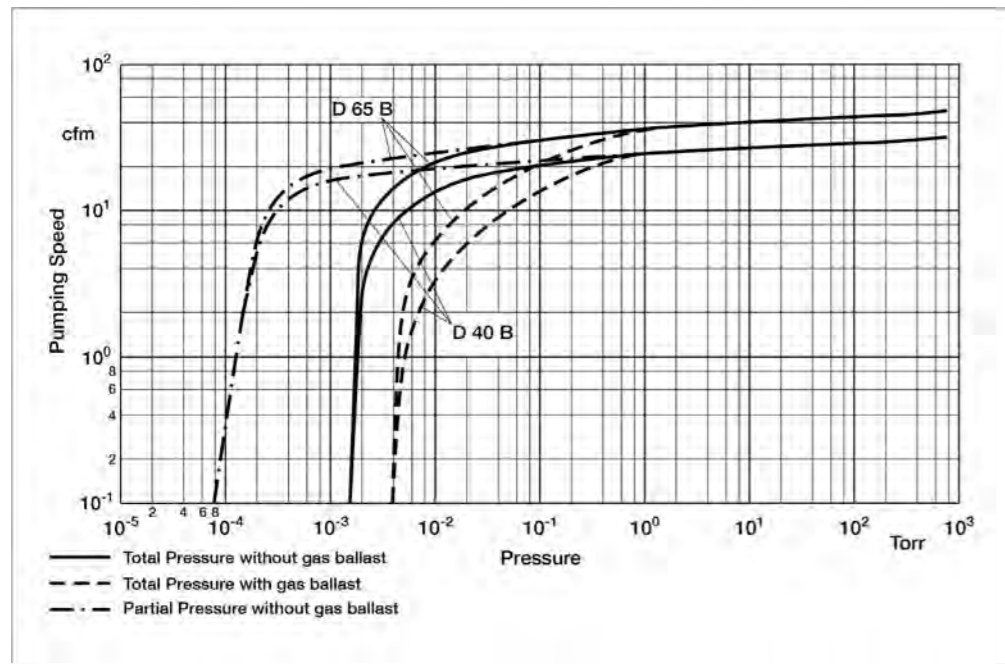

Pumping speed characteristics for the TRIVAC D 40 B/BCS and D 65 B/BCS at 60 Hz

# General

## Applications for NEO D pumps

Pumps	NEO D 16	NEO D 25	NEO D 40	NEO D 65
<b>Applications</b>				
Vacuum coating	■	■	■	■
Research and development	■	■	■	■
Chemistry / Pharmaceuticals	■	■	■	■
Metallurgy / Furnaces	■	■	■	■
Automotive industry	■	■	■	■
Analytical engineering	■	■	■	■
Cooling and air-conditioning	■	■	■	■
Electrical engineering	■	■	■	■
Medicine technology	■	■	■	■
Glove Boxes	■	■	■	■
Sterilisation	■	■	■	■
Freeze drying systems	■	■	■	■
Backing pump for high vacuum pump systems	■	■	■	■
Leak testing	■	■	■	■
Resin degassing / Composites	■	■	■	■

The table only lists general applications. Your specific requirements might be subject to deeper analysis. For further questions, please contact our technical Sales support.

# Oil for NEO D pumps for different fields of application

Applications	Fields of Application														
	Vacuum coating	Research and development	Chemistry / Pharmaceutical	Metallurgy / Furnaces	Automotive industry	Analytical engineering	Cooling and air-conditioning	Electrical engineering	Medicine technology	Glove boxes	Sterilisation	Freeze drying systems	Backing pump for HV pump	Leak testing	Resin degassing Composites
<b>LEYBONOL Oils</b>															
LVO 120 Mineral	■	■	■			■		■				■	■		
LVO 140 Food grade											■				
LVO 700 Long life	■	■	■		■	■		■	■	■	■	■	■		■

These oils can be used in all NEO D sizes.

Other oils from the LEYBONOL Catalogue can be used as well, please contact our technical Sales support. Depending of the chosen oil type different technical data may be applicable. Technical information is valid for LVO 120, LVO 140, LVO 700 when the pump is in warm condition.

The table only lists general applications. Your specific requirements might be subject to deeper analysis. For further questions, please contact our technical Sales support.

**For information on oil specifications please refer to Catalog Part**

**“Oils / Greases / Lubricants LEYBONOL®”.**

# Product Range, Features and Design

Oil sealed rotary vane vacuum pumps are being used in all areas of vacuum engineering. They are equally suited for both industrial production and research applications. They are best used to generate medium vacuum or as backing pumps in pump combinations with Roots vacuum pumps or high vacuum pumps.

The double stage NEO D rotary vane pumps excel also to their low noise levels and smooth operation. Many years of experience in vacuum engineering and the latest developments in pump technology combine in the NEO D range the capability to adapt to the requirements of both the industry and the environment.

- Sterilisation
- Freeze drying systems
- Backing pump for high vacuum pump systems
- Leak testing
- Resin degassing / Composites

### Advantages to the User

- Integrated exhaust filter. No external accessory required. Exhaust gas free of oil mists. Oil loss < 1 ppm
- Continuous operation from atmospheric pressure to ultimate pressure

- Lowest noise and vibration levels on the market
- Efficient air cooling (standard)
- Low space requirement, easy to install thanks to integrated exhaust filter
- Very Maintenance-friendly due to oil drain valve and easy to change exhaust filter
- Wide range of accessories available

### Main Application Examples

- Research and development
- Chemistry / Pharmaceuticals
- Metallurgy / Furnaces
- Analytical engineering
- Cooling and air-conditioning
- Medicine technology
- Glove Boxes

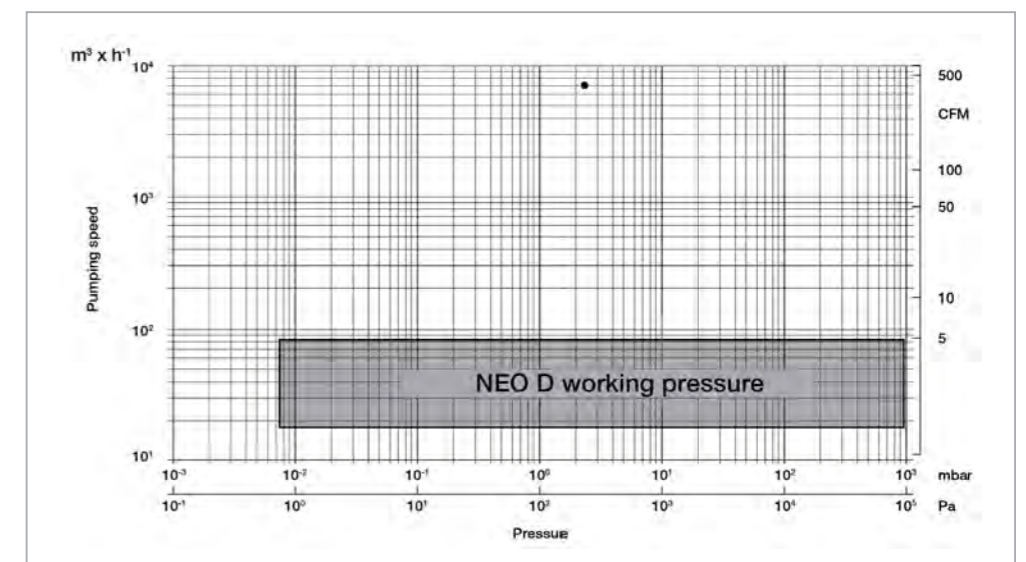

Working pressure of NEO D pumps

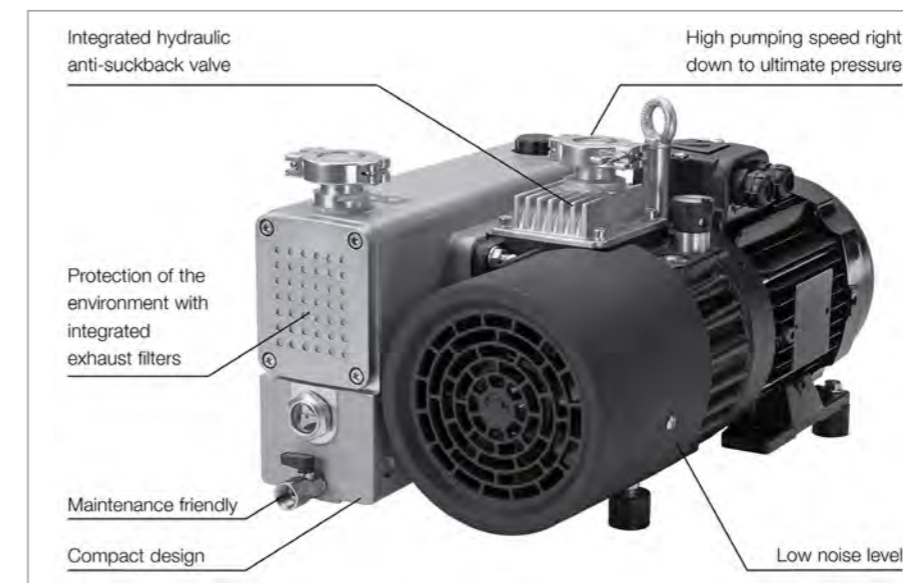

Outstanding features of the NEO pumps



## Design Principle

NEO D pumps are double stage oil sealed rotary vane pumps. Oil injected into the pump chamber for sealing, lubrication and cooling of the pump is recycled from the pump's oil reservoir and filtered. The lubrication system is rated for continuous operation at high intake pressures (max. 1000 mbar abs.) so that the pumps may be used in a versatile manner from atmospheric down to ultimate pressure.

The oil carried with the process gas is roughly separated in the oil box before the discharged gas enters the integrated exhaust filters where the fine oil mist is trapped. The thus filtered oil is collected in the oil box and then supplied back to the pump.

The separating system optimized in consideration of all operating conditions for the vacuum pump guarantees – also at high intake pressures and when pumping out of vapors – an exhaust gas which is free of oil mist (separation efficiency over 99.9%).

Materials used in the pump:

Steel, Cast iron, Aluminium, FPM (FKM), Glass, Polyamid 6 6, Filter material (Polymers, Paper), Epoxy resin & Glass fibre.

Pumps are yellow metal free.

## Compact Design

The pumps have been so designed that efficiency of the pumps will be highest. The motor and vacuum generator section use the same shaft. All vacuum components like anti-suck back, exhaust filter with oil return line needed for a complete vacuum unit as well as the optimized placement of all controls and monitoring components allow for an extremely compact unit.

## Quiet Operation

NEO D pumps are designed throughout to keep the noise level as low as possible. This is ensured by optimized running and sliding speeds and the selection of low-noise drive motors and fans, as well as perfected manufacturing techniques using CNC automatic machines for optimized tolerances and reproducibility of the individual components.

## Anti-Suckback Valve

A valve is built into the intake of the NEO D pumps. This "anti-suck back valve" (called ASBV) is protected by a metal wiremesh filter. During standstill of the pump (for example due to shutting down or a power failure) the ASBV closes the intake hydraulically & very fast. This prevents the pressure from rising in the connected chamber while the pump is vented at the same time. Any suck-back of pump oil into the vacuum system is thus also effectively prevented. This closing process operates under all operating conditions and even when the gas ballast valve is open.

## Protection of the Environment

The built-in exhaust filter ensures an oil-mist free exhaust gases over the entire range of operating pressures – from atmospheric pressure to ultimate pressure.

## Supplied Equipment

All pumps are delivered with the required quantity of oil, already filled in and are thus ready for operation.

## Frequency converter drive (optional)

- FC drive enables:
  - Speed control
  - Monitoring (RS485 interface)
  - Constant pumping speed independent of mains frequency
  - Soft start w/o inrush current
  - Even lower noise and vibration levels than a 1-phase motor
- 1-phase power supply 180 ... 264 V at 50 & 60 Hz, for all pump sizes!

## Pump failure indicator (optional)

Do you need to keep an eye on the status of your pump, even when you are not on site? Our pump failure indicator enables remote monitoring:

- 1. Oil level**  
Indicates a too low oil level
- 2. Oil temp**  
Indicates overheating
- 3. Exhaust filter condition (back-pressure)**  
Indicates that the exhaust filter needs to be changed

# Products

## NEO D 16 / D 25 / D 40 / D 65

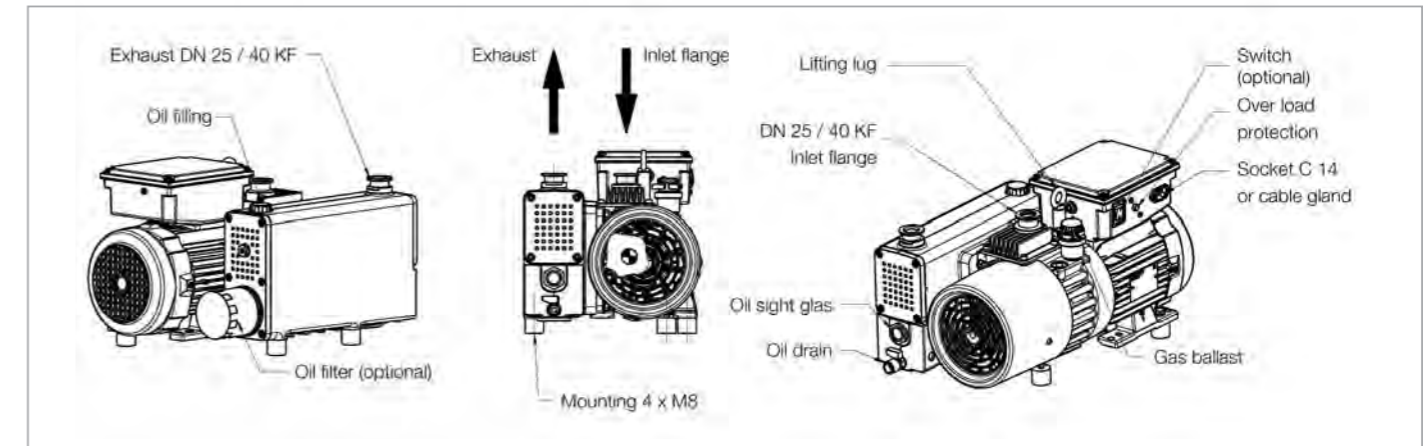

Typical location of main pump components

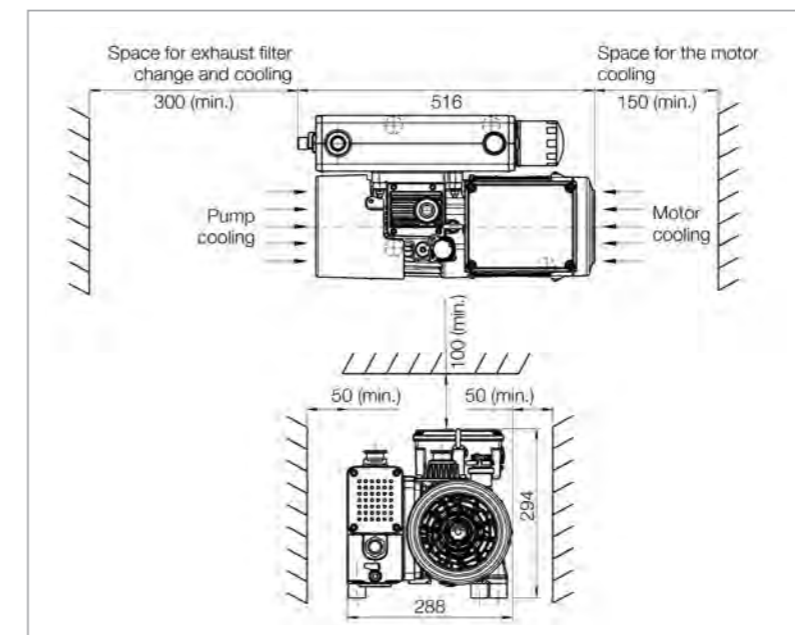

Main installation clearance (in mm)

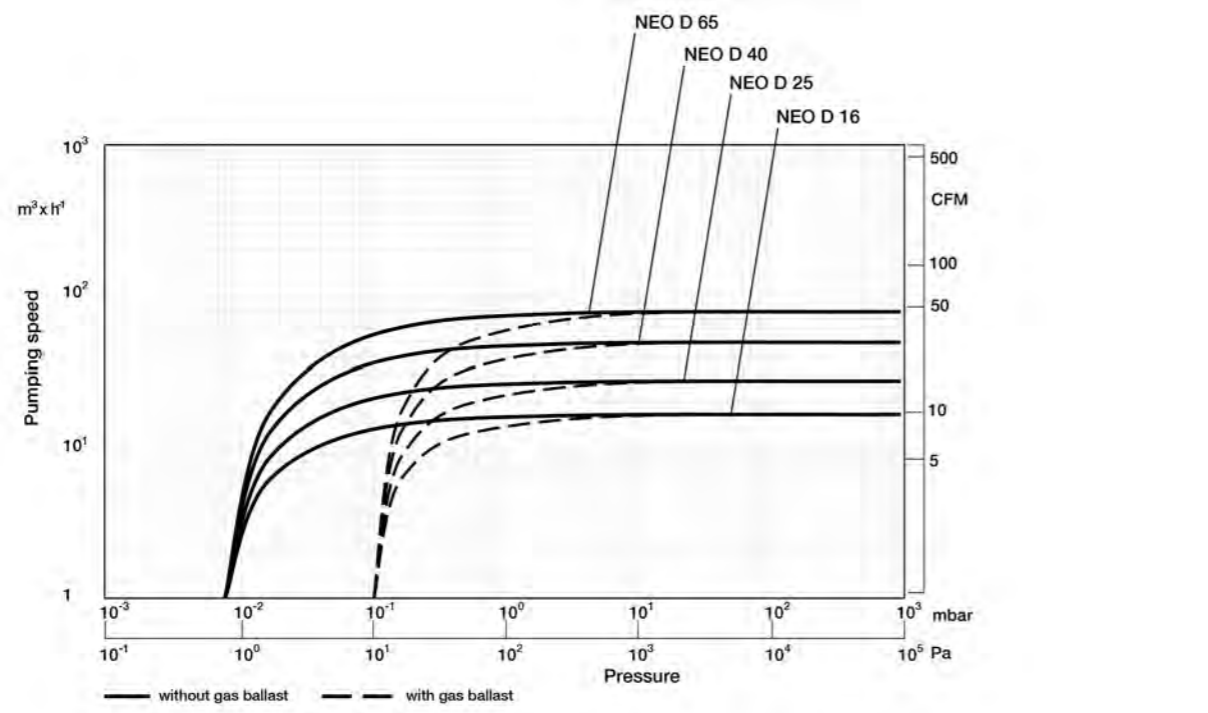

Pumping speed characteristics of the NEO D 16, D 25, D 40 and D 65 at 50 Hz

		NEO							
		D 16		D 25		D 40		D 65	
		50 Hz	60 Hz	50 Hz	60 Hz	50 Hz	60 Hz	50 Hz	60 Hz
Nominal speed <sup>1)</sup>	m³/h (cfm)	19 (11.18)	23 (13.54)	28 (16.48)	34 (20.01)	47 (27.66)	56 (32.96)	74 (43.55)	89 (52.38)
Pumping speed <sup>1)</sup>	m³/h (cfm)	16 (9.42)	19 (11.18)	24 (14.13)	29 (17.07)	40 (23.54)	48 (28.25)	63 (37.08)	76 (44.73)
Ultimate total pressure without gas ballast <sup>1)</sup>	mbar (Torr)	$< 8 \times 10^{-3}$ ( $< 6 \times 10^{-3}$ )							
Ultimate total pressure with gas ballast <sup>1)</sup>	mbar (Torr)	$< 1 \times 10^{-1}$ ( $< 0.75 \times 10^{-1}$ )							
Water vapor tolerance <sup>1)</sup>	mbar (Torr)	10 (7.5)							
Oil capacity	l (qt)	1.5 (1.59)				3 (3.17)			
Noise level <sup>2)</sup>	dB(A)	54	55	54	55	57	58	57	58
Motor power									
three-phase motor	kW (hp)	0.55 (0.75)	0.70 (0.95)	0.9 (1.22)	1.1 (1.5)	1.15(1.54)	1.5 (2.04)	2.0 (2.72)	2.6 (3.54)
single-phase motor	kW (hp)	0.75 (1.02)	0.9 (1.22)	0.9 (1.22)	1.1 (1.5)	1.3 (1.77)	1.6 (2.18)	—	—
Frequency converter	kW (hp)	0.75 (1.02)	0.9 (1.22)	0.9 (1.22)	1.1 (1.5)	1.5 (2.04)	1.5 (2.04)	2.0 (2.72)	2.2 (2.99)
Weight	kg (lbs)	48 (106)		48 (106)		80 (176)		88 (194)	
Flanges	DN	25 ISO-KF				40 ISO-KF			
Dimensions (L x W x H) <sup>3)</sup>	mm (in.)	516 x 288 x 294 (20.32 x 11.34 x 11.57)		516 x 288 x 294 (20.32 x 11.34 x 11.57)		632 x 356 x 320 (24.88 x 14.02 x 12.60)		669 x 359 x 320 (26.34 x 14.13 x 12.60)	
three-phase motor	mm (in.)	516 x 288 x 294 (20.32 x 11.34 x 11.57)		516 x 288 x 294 (20.32 x 11.34 x 11.57)		632 x 356 x 320 (24.88 x 14.02 x 12.60)		—	
single-phase motor	mm (in.)	516 x 288 x 294 (20.32 x 11.34 x 11.57)		516 x 288 x 294 (20.32 x 11.34 x 11.57)		12.60		—	

<sup>1)</sup> To DIN 28 400 and following numbers  
<sup>2)</sup> Operated at the ultimate pressure without gas ballast, free-field measurement at a distance of 1 m (3.5 ft), with LVO 120, LVO 140 or LVO 700 oil  
<sup>3)</sup> Dimensions may vary in function of mounted accessories or specific motors

**Ordering Information**

	NEO			
	D 16	D 25	D 40	D 65
	Part No.	Part No.	Part No.	Part No.
3-phase world motor <sup>1)</sup> 180...264 / 342...457 V, 50 Hz & 180...264 / 342...506 V, 60 Hz	970102V	970202V	970302V	970402V
1-phase <sup>1)</sup> 180 - 264 V, 50 & 60 Hz with overload protection, w/o power cable	970100V C14 socket	970200V C14 socket	970300V C20 socket	-
1-phase <sup>1)</sup> 115 V ± 10%, 60 Hz with overload protection, with NEMA 6-15P power cable	970103V	-	-	-
Accessories <sup>2)</sup>				
External frequency converter for variable speed operation between 40 and 60 Hz and monitoring. Supply voltage 1ph 200-240 V ± 10 %, 50/60 Hz				970FC01
Roots adapter WA(U) 251/501	-	-	970RA02	970RA01
Oil level switch	9700LS			
Exhaust filter pressure switch	971471210			
Exhaust filter pressure manometer	95193			
Temperature switch sizes 16 / 25 / 40	9700TS			
Temperature switch sizes 65	9700TS65			
PT100 sensor	-	-	971444320	
Gas ballast				
EM 24 V DC, 0.5 A	9700GBDC			
Permanent	9700GBP			
Permanent with 16 KF	EK6702221			
Manual with 16 KF	9700GBA			
Spare parts for standard pumps				
Exhaust filter	EK6702228	EK6702158	EK6702490	EK6702425
Oil filter	EK96004			
Maintenance kit	EK9701M	EK9702M	EK9703M	EK9704M
Repair kit	EK9701RES	EK9702RES	EK9703RES	EK9704RES
Seal kit	EK9701SK	EK9702SK	EK9703SK	EK9704SK
Consumables				
Oil				
Long life LVO 700	2 x L70001		3 x L70001	
Mineral LVO 120	2 x L12001		3 x L12001	

<sup>1)</sup> Pumps delivered filled in with LVO700 oil  
<sup>2)</sup> All accessories can be retrofitted.  
 For the pump inlet accessories (e.g. inlet filters, inlet absorption traps etc.) kindly consult TRIVAC B Catalogue Section  
 For the connection fittings, kindly consult the Flanges & Fittings Catalogue Section

# General

## Applications for SOGEVAC pumps

Pumps	SOGEVAC SV 10 B	SOGEVAC SV 16 B	SOGEVAC SV 25 B	SOGEVAC SV 16 D(I)	SOGEVAC SV 25 D	SOGEVAC SV 40 B	SOGEVAC SV 65 B	SOGEVAC SV 100 B	SOGEVAC SV 120 B	SOGEVAC SV 200	SOGEVAC SV 300 B / 320 B	SOGEVAC SV 470/570 B	SOGEVAC SV 470/570 BF	SOGEVAC SV 630 B	SOGEVAC SV 630 BF	SOGEVAC SV 750 B/BF	SOGEVAC SV 28 - 120 BI	SOGEVAC SV 40 ATEX
<b>Applications</b>																		
Vacuum coating							■	■	■	■	■	■	■	■	■	■		
Research and development			■	■													■	
Chemistry / Pharmaceuticals			■		■	■	■	■	■									■
Metallurgy / Furnaces					■	■	■	■	■	■	■	■	■	■	■	■		
Automotive industry	■	■	■	■	■	■	■	■	■	■	■	■	■	■	■	■		■
Space simulation							■		■	■	■	■	■	■	■			
Analytical engineering				■														■
Environment engineering			■	■	■	■	■	■	■									■
Cooling and air-conditioning	■	■	■	■														
Electrical engineering				■		■	■	■	■	■	■	■	■	■	■	■		
Mechanical engineering				■		■	■	■	■	■	■	■	■	■	■	■		■
Medicine technology		■	■	■	■	■	■	■	■									■
Freeze drying systems				■		■	■	■	■	■	■	■	■	■	■	■		
Backing pump for high vacuum pump systems	■	■	■	■		■	■											■
Food industry	■	■	■	■		■	■	■	■	■	■	■	■	■	■			
Plant engineering	■	■	■	■	■	■	■	■	■	■	■	■	■	■	■	■		
Power engineering / District heating				■		■	■	■	■									
Cleaning										■	■	■	■	■	■			
Packaging	■	■	■	■		■	■	■	■	■	■	■	■	■	■			

## Oil for SOGEVAC pumps for different fields of application

Applications	Vacuum coating	Research and development	SOGEVAC SV 25 B	Metallurgy / Furnaces	Lamps and tubes manufactures	Automotive industry	Laser technology	Space simulation	Analytical engineering	Environment engineering	Electrical engineering	Mechanical engineering	Medicine engineering	Vacuum technology	Backing pump for HV pump systems	Food industry	Plant engineering	Power engineering	Packaging/district heating	Cleaning	
<b>LEYBONOL Oils</b>																					
LVO 120	■	■	■	■	■	■	■	■	■	■	■	■	■	■	■	■	■	■	■	■	■
LVO 130	■	■	■	■	■	■	■	■	■	■	■	■	■	■	■	■	■	■	■	■	■
LVO 140									■	■				■						■	
LVO 150									■	■				■						■	
LVO 211	■	■	■	■	■	■					■						■	■			
LVO 300			■					■	■	■	■	■	■	■	■	■	■	■	■	■	■
LVO 400	■	■	■								■			●	■					■	
LVO 420								■													
LVO 700/710	■	■	■	■	■	■	■	■	■	■	■	■	■	■	■	■	■	■	■	■	■
DOT 4					■																

■ = Standard  
● = Possible

The table only lists general applications. Your specific requirements might be subject to deeper analysis. For further questions, please contact our technical Sales support.

**For information on oil specifications please refer to Catalog Part "Oils / Greases / Lubricants LEYBONOL®".**

# Oil for SOGEVAC pumps for different pump types

Applications	Pump line													
	D	A	B / BF	BI	ATEX									
	SV 16 D, SV 25 D	SV 40, SV 65	SV 100	SV 200, SV 200 FP	SV 500, SV 630, SV 750	SV 10 B, SV 16 B/FP	SV 25 B/FP	SV 40 B, SV 45 FP	SV 65 B, SV 100 B, SV 120 B/FP	SV 300 B (FP) to SV 750 B (F)	SV 16 D1 to SV 120 B1	SV 40 B category 1 (I)/2(o) IIA	SV 40 B category 1 (I)/2(o) IIB + H2	SV 40 B to 630 B category 3 (I)/3(o)
<b>LEYBONOL Oils</b>														
LVO 120	■	■		■	■	▲ <sup>1)</sup>			■					
LVO 130	▲	■	■	■	■	▲ <sup>2)</sup>	■	■						
LVO 140	●	●	●		●	●	▲	▲						
LVO 150		●	●	●	▲	●	●	●						
LVO 211	▲ <sup>2)</sup>	▲ <sup>2)</sup>	●	●	●	▲	▲	●	●				■	■
LVO 300	●	●	●	●	▲		●	●	▲					▲
LVO 400	●	●	●	●				●	●					● <sup>3)</sup>
LVO 420													■	
LVO 700	●				●	●			●					
LVO 710		●	●	●	●			●	●	●	●	●	●	●
DOT 4		●				●								

- = Standard
- = Possible
- ▲ = Please contact Leybold Valence

<sup>1)</sup> = with single-phase motor  
<sup>2)</sup> = with three-phase motor  
<sup>3)</sup> = ATEX outside only

The table only lists general applications. Your specific requirements might be subject to deeper analysis. For further questions, please contact our technical Sales support.

**For information on oil specifications please refer to Catalog Part "Oils / Greases / Lubricants LEYBONOL®".**

# Product Range, Features and Design

Oil sealed rotary vane vacuum pumps are being used in all areas of vacuum engineering. They are equally suited for both industrial production and research applications. They may be used to generate a rough and medium vacuum or as backing pumps in pump combinations with Roots vacuum pumps or high vacuum pumps. The SOGEVAC pumps excel also to their low noise levels and smooth operation.

Many years of experience in vacuum engineering and the latest developments in pump technology combine in the SOGEVAC range the capability to adapt to the requirements of both the industry and the environment. The comprehensive range (pumping speeds ranging from 10 to 750 m<sup>3</sup> x h<sup>-1</sup> (5.9 to 441.4 cfm)) allows every customer to select the right pump for his particular needs.

### Application Examples

- Automotive industry
- Food industry
- Furnaces and plants
- Vacuum coating
- Metallurgy
- Power engineering, long-distance energy
- Space simulation
- Laser technology
- Medicinal technology

### Advantages to the User

- Continuous operation from atmospheric pressure to ultimate pressure
- High pumping speed also at low pressures
- Low noise level
- Low vibrations
- Integrated exhaust filter, better than 99.9% efficient
- No oil loss owing to the integrated oil return line
- Exhaust gas free of oil mists
- Efficient air cooling (standard)
- Water cooling (optional)
- Low space requirement, easy to install
- Rugged
- Maintenance-friendly
- Compact design
- For direct fitting to Roots pumps from SV 100 B up
- Optimum size-to-performance ratio
- High water vapor tolerance
- For use in various applications
- Wide range of accessories available for adaptation to differing problems

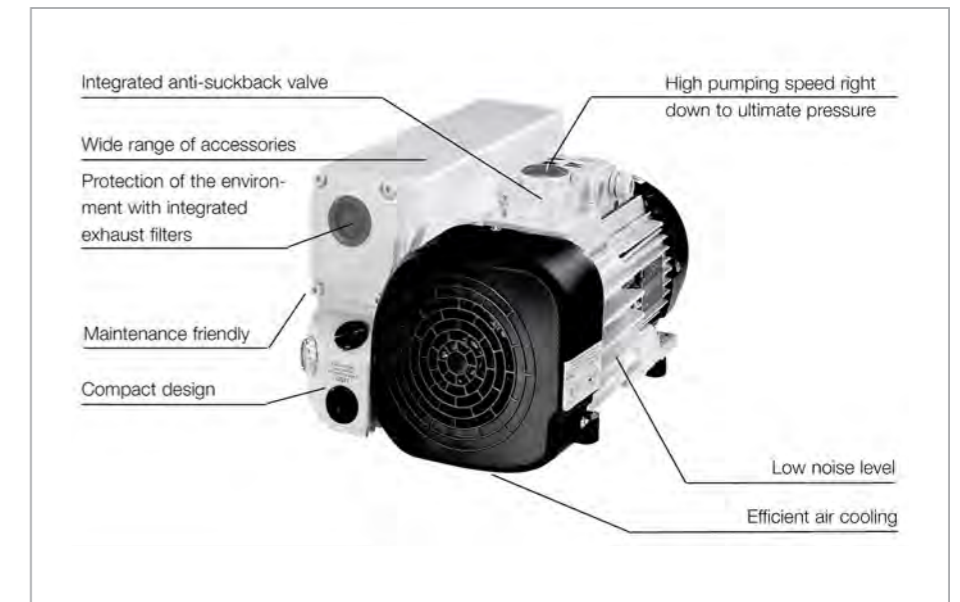

Outstanding features of the SOGEVAC pumps

## Design Principle

SOGEVAC pumps are oil sealed rotary vane pumps. Oil injected into the pump chamber for sealing, lubrication and cooling of the pump is recycled from the pump's oil reservoir and filtered, if required, before it is injected. The lubricant system is rated for continuous operation at high intake pressures (max. 1000 mbar abs.) so that the pumps may be used in a versatile manner in most rough vacuum applications (accessories are required for some pumps).

The oil carried with the process gas is roughly separated in the oil box before the discharged gas enters the integrated exhaust filters where the fine oil mist is trapped. The thus filtered oil is collected in the oil box and then supplied back to the pump.

The separating system optimized in consideration of all operating conditions for the vacuum pump guarantees – also at high intake pressures and when pumping out of vapors – an exhaust gas which is free of oil mist (separation efficiency over 99.9%).

Materials used in the pump:  
Steel, Cast iron, Aluminium, Bronze, FPM (FKM), Glass, Polyamid 6.6, Filter material (Polymers, Paper), Epoxy resin & Glass fibre.

Leybold rotary vane vacuum pumps from the SOGEVAC series excel through numerous special features:

## Compact Design

The pumps have been so designed that efficiency of the pumps will be high.

For the SV 10 B through SV 65 B, the motor and pumping section use the same shaft. For the SV 100 B to SV 750 B the motor is linked depending on requirements to the pumping section directly via a coupling or via V-belts as a pedestal motor. All vacuum components like anti-suckback, exhaust filter with oil return line needed for a complete vacuum unit as well as the optimized placement of all controls and monitoring components allow for an extremely compact unit.

## Quiet Operation

SOGEVAC pumps are designed throughout to keep the noise level as low as possible. This is ensured by optimized running and sliding speeds and the selection of low-noise drive motors, as well as perfected manufacturing techniques using CNC automatic machines for optimized tolerances and reproducibility of the individual components.

## Anti-Suckback Valve

A valve is built into the intake of the SOGEVAC pumps. This "anti-suckback valve" is protected by a metal wiremesh filter. During standstill of the pump (for example due to shutting down or a power failure) the valve closes the intake. This prevents the pressure from rising in the connected chamber while the pump is vented at the same time. Any suck-back of pump oil into the vacuum system is thus also effectively prevented. This blocking process operates under all operating conditions (below 800 mbar (600 Torr)) and even when the gas ballast valve is open.

## Protection of the Environment

The built-in exhaust filter ensures an oil-mist free exhaust gases over the entire range of operating pressures – from atmospheric pressure to ultimate pressure.

## Supplied Equipment

All pumps are delivered with the required quantity of oil: SV 10 B to SV 65 B in a separate canister, whereas the SV 100 B and larger pumps already contain the oil and are thus ready for operation.

PFPE variants are typically delivered without fluid LVO 400.

# Products

## SOGEVAC SV 10 B / SV 16 B



SOGEVAC SV 16 B

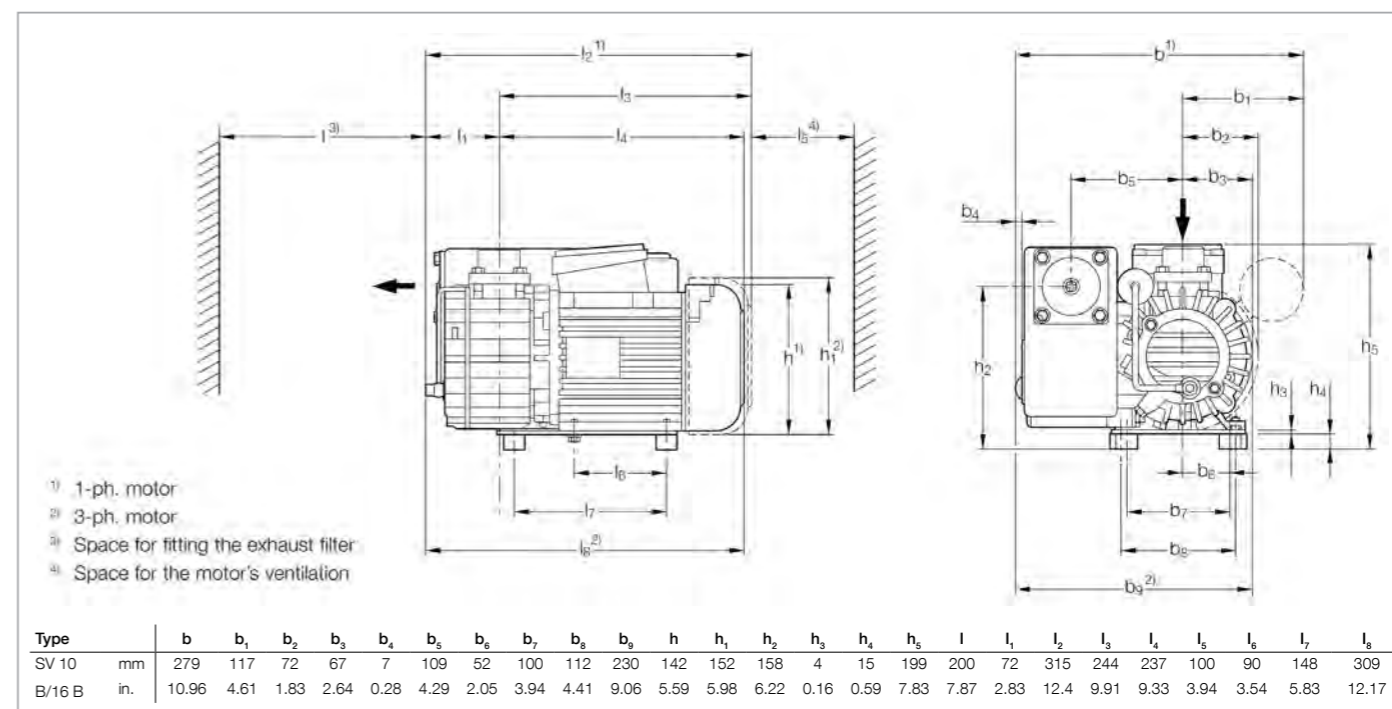

Dimensional drawing for the SOGEVAC SV 10 B and SV 16 B

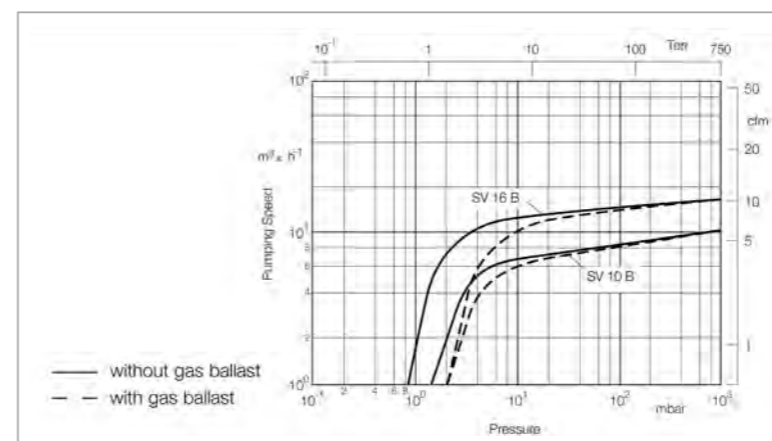

Pumping speed characteristics of the SOGEVAC SV 10 B and SV 16 B at 50 Hz (60 Hz curves at the end of the chapter)

### Technical Data

		SOGEVAC SV 10 B		SOGEVAC SV 16 B	
		50 Hz	60 Hz	50 Hz	60 Hz
Nominal speed <sup>1)</sup>	m <sup>3</sup> /h (cfm)	11.0 (6.5)	13.0 (7.7)	16.0 (9.4)	19.0 (11.2)
Pumping speed <sup>1)</sup>	m <sup>3</sup> /h (cfm)	9.5 (5.6)	11.5 (6.8)	15.0 (8.8)	17.0 (10.0)
Ultimate total pressure without gas ballast <sup>1)</sup>	mbar (Torr)	≤ 1.5 (≤ 1.1)	≤ 1.5 (≤ 1.1)	≤ 1.0 (≤ 0.8)	≤ 1.0 (≤ 0.8)
Ultimate total pressure with gas ballast <sup>1)</sup>	mbar (Torr)	≤ 2.5 (≤ 1.9)	≤ 2.5 (≤ 1.9)	≤ 2.0 (≤ 1.5)	≤ 2.0 (≤ 1.5)
Water vapor tolerance <sup>1)</sup>	mbar (Torr)	10.0 (7.5)	15.0 (11.3)	10.0 (7.5)	15.0 (11.3)
Water vapor capacity	g/h (qt/hr)	20 (0.02)	30 (0.03)	30 (0.03)	50 (0.05)
Oil capacity	l (qt)	0.5 (0.53)			
Noise level <sup>2)</sup>	dB(A)	62 (1-ph.) – 60 (3-ph.)	66 (1-ph.) – 64 (3-ph.)	62 (1-ph.) – 60 (3-ph.)	66 (1-ph.) – 64 (3-ph.)
Admissible ambient temperature	°C (°F)	12 to 40 (54 to 104)			
Motor power	kW (hp)	0.55 (0.75)	0.75 (1.02)	0.55 (0.75)	0.75 (1.02)
Nominal speed	min <sup>-1</sup> (rpm)	3000 (3000)	3600 (3600)	3000 (3000)	3600 (3600)
Type of protection	IP	55-F			
Weight (with oil filling)	kg (lbs)	20.0 (41.55)	20.0 (41.55)	20.5 (45.25)	20.5 (45.25)
Dimensions (L x W x H)	mm (in.)	315 x 281 x 199 (12.4 x 11.06 x 7.83)			
Connections intake (Inside thread) <sup>3)</sup>	G	3/4" + 1/2"			

### Ordering Information

	SOGEVAC SV 10 B		SOGEVAC SV 16 B	
	50 Hz	60 Hz	50 Hz	60 Hz
	Part No.		Part No.	
SOGEVAC SV 10 B/SV 16 B with three-phase motor, with permanent gas ballast 220–240/380–415 V, 50 Hz and 220–266/380–460 V, 60 Hz (CEI)	960 100		960 160	
200 V, 50/60 Hz	-		960 175	
with single-phase motor <sup>4)</sup> , with permanent gas ballast 230 V, 50/60 Hz (CEI)	960 105		960 165	
110–120 V, 60 Hz	960 110		960 170	
100 V, 50/60 Hz	960 114		-	
Other voltages/frequencies <sup>5)</sup>	upon request		upon request	
Filling with special oil	upon request		upon request	
<b>Accessories</b>				
Exhaust filter cartridge AFE SV10B/16B	714 13 280		714 13 280	
Exhaust connection G 3/4"	971 433 140		971 433 140	
<b>Spare Parts</b>				
Repair kit	714 22 230		714 22 230	
Maintenance kit	971 444 430		971 444 430	
Seal kit FPM (FKM)	714 22 220		714 22 220	

<sup>1)</sup> To DIN 28 400 and following numbers

<sup>2)</sup> Operated at the ultimate pressure without gas ballast, free-field measurement at a distance of 1 m (3.5 ft)

<sup>3)</sup> 1/2" adapter supplied. Basic port is 3/4"

<sup>4)</sup> Single-phase motors do not have plugs, cords or ON/OFF switches

<sup>5)</sup> Please indicate when ordering a pump

Materials (materials in contact with the process gas) Steel cast iron, Aluminium, Bronze, FPM (FKM), Glass, Polyamid 6.6, Filter material, (Polymers, Paper) Epoxy resin and Glass fibre

**Remark:** The SV 10 B and SV 16 B cannot work continuously above 150 mbar. Please consult Leybold for this application

# SOGEVAC SV 16 D / SV 16 DI / SV 25 D



SOGEVAC SV 16 D / 16 DI / 25 D

### Advantages to the User

- Good pump temperature due to optimized air cooling. Add water cooling possible, ideal for harsh applications and optimal oil life time thus reached
- 4 times more oil than on comparable pumps allow long oil life times
- Optimized integrated lubrication without external pipes
- Integrated oil recovery system and anti suckback valve
- Low noise level due to low pump speed
- Variant concept
- 3 phase wide range motors
- Different single phase motors with overload protection in accordance to EN 61010-1
- Compact and nice design

### Typical Applications

- Oil purification, drying and de gassing
- Plastic and rubber injection presses
- O<sub>2</sub> applications
- Analytical Instruments
- and more ...

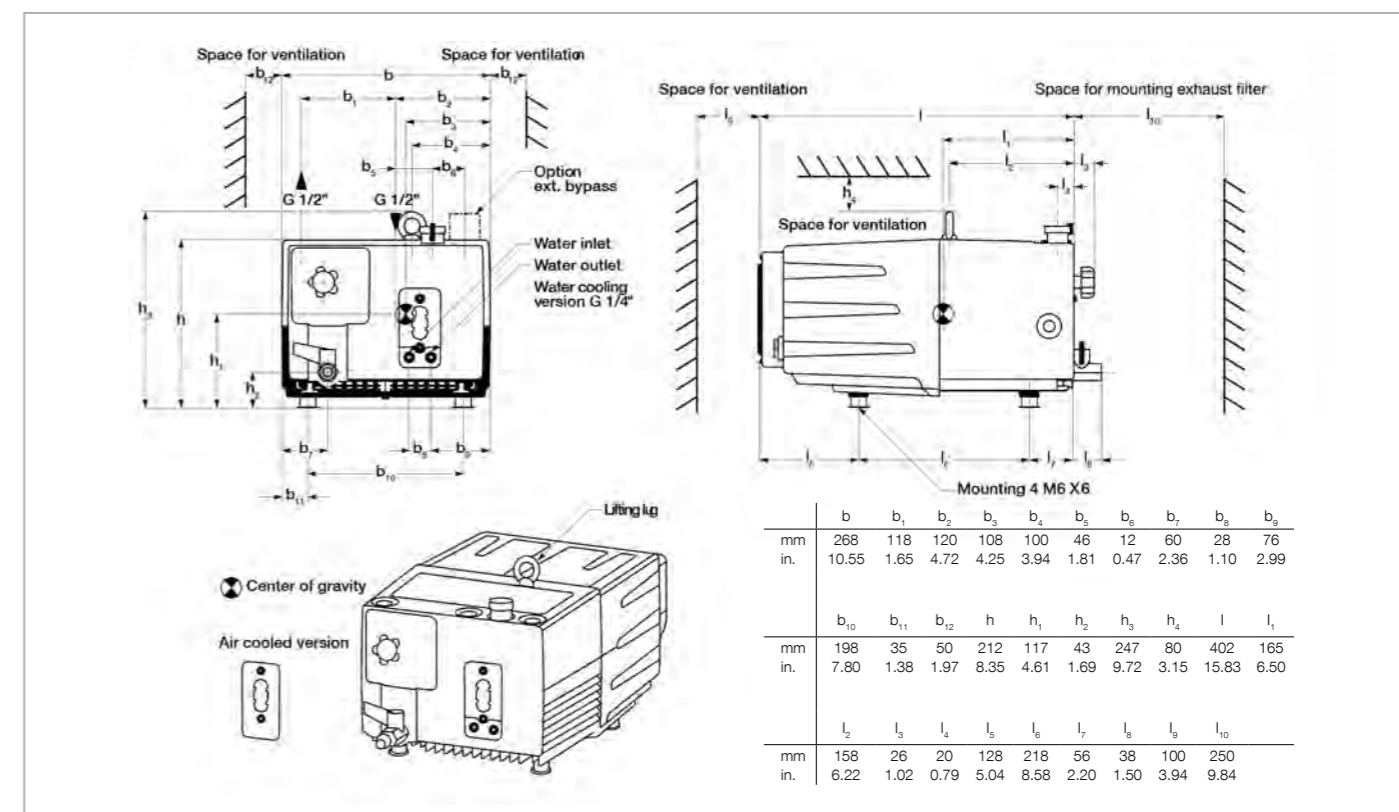

Dimensional drawing for the SOGEVAC SOGEVAC SV 16 D / 16 DI / 25 D

Technical Data		SOGEVAC SV 16 D		SOGEVAC SV 16 DI		SOGEVAC SV 25 DI	
		50 Hz	60 Hz	50 Hz	60 Hz	50 Hz	60 Hz
Nominal speed <sup>1)</sup>	m <sup>3</sup> /h (cfm)	16.0 (9.4)	18.7 (11.0)	16.0 (9.4)	18.7 (11.0)	25.0 (14.7)	29.0 (17.0)
Pumping speed <sup>1)</sup>	m <sup>3</sup> /h (cfm)	14.5 (8.5)	17.0 (10.0)	14.5 (8.5)	17.0 (10.0)	22.5 (13.3)	25.5 (15.0)
Ultimate total pressure without gas ballast <sup>1)</sup>	mbar (Torr)	≤ 0.5 (≤ 0.4)		≤ 0.1 (≤ 0.08)		≤ 0.5 (≤ 0.4)	
Ultimate total pressure with gas ballast <sup>1)</sup>	mbar (Torr)	≤ 1.5 (≤ 1.1)		≤ 1.0 (≤ 0.8)		≤ 1.5 (≤ 1.1)	
Water vapor tolerance <sup>1)</sup>	mbar (Torr)	15.0 (11.3)					
Water vapor capacity	kg/h (qt/hr)	0.05 (0.05)	0.15 (0.16)	0.05 (0.05)	0.15 (0.16)	0.05 (0.05)	0.15 (0.16)
Oil capacity	l (qt)	2.0 (2.1)					
Noise level <sup>2)</sup>	dB(A)	≤ 59					
Type of protection	IP	21-F					
Admissible ambient temperatur							
1~ (oil: 32 cSt, approx.)	°C (°F)	+18 to +40 (+64 to 104)					
3~	°C (°F)	+12 to +40 (+54 to 104)					
Motor power (1~ and 3~), approx.	kW (hp)	0.75 (1.01)	0.90 (1.21)	0.75 (1.01)	0.90 (1.21)	0.75 (1.01)	0.90 (1.21)
Nominal speed	min <sup>-1</sup> (rpm)	1440 (1440)	1750 (1750)	1440 (1440)	1750 (1750)	1440 (1440)	1750 (1750)
Weight (with oil filling)	kg (lbs)	25 (55.1)					
Connections, Intake and Exhaust <sup>3)</sup>		1/2" NPT/G		25 ISO-KF		1/2" NPT/G	

<sup>1)</sup> To DIN 28 400 ff  
<sup>2)</sup> Operated at the ultimate pressure without gas ballast, free-field measurement at a distance of 1 m (3.5 ft)  
<sup>3)</sup> Please indicate when ordering a pump

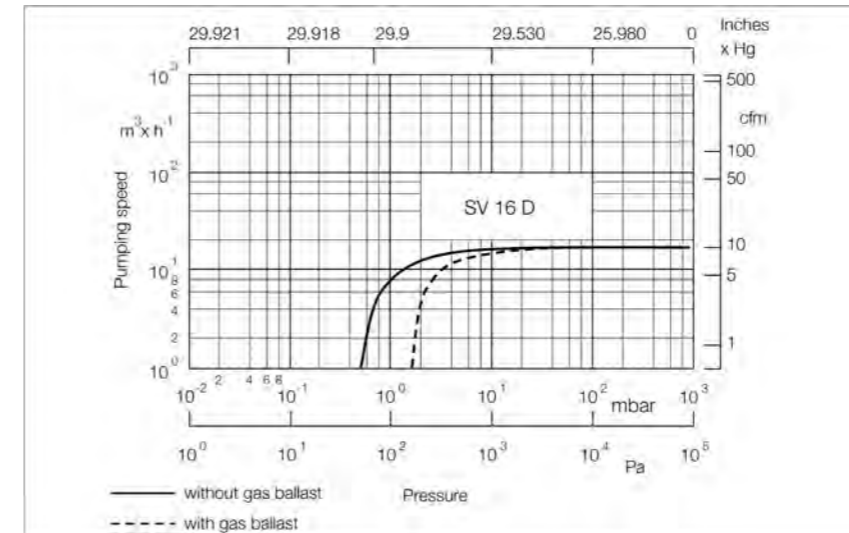

Pumping speed characteristics of the SOGEVAC SV 16 D at 50 Hz\*

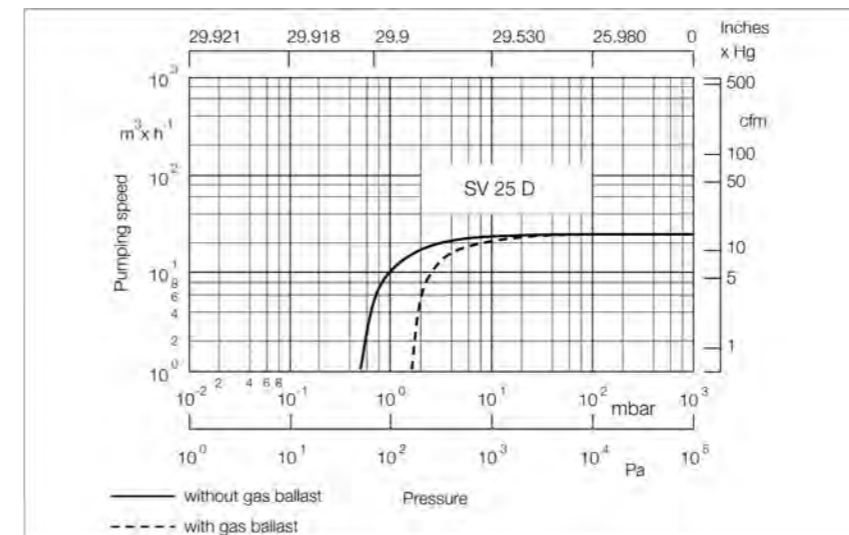

Pumping speed characteristics of the SOGEVAC SV 25 D at 50 Hz\*

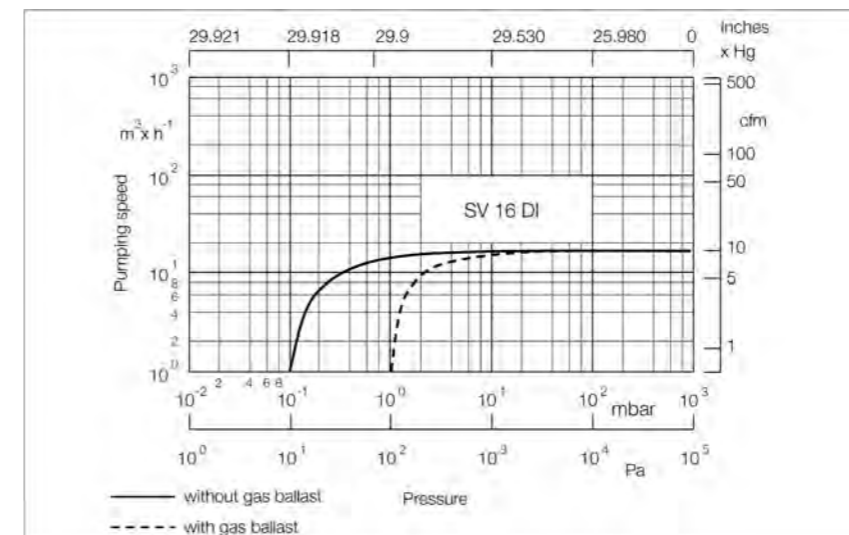

Pumping speed characteristics of the SOGEVAC SV 16 DI at 50 Hz\*

\* 60 Hz curves at the end of the chapter

### Ordering Information

### SOGEVAC SV 16 D(I)

### SOGEVAC SV 25 D

	Part No.	Part No.
<b>SOGEVAC SV 16 D / SV 25 D</b> with UL/CSA world three-phase motor and integrated gas ballast valve 200 – 240 V ±10% and 380 – 415 V ±10%, 50 Hz / 200 – 240 V ±10% and 380 – 460 V ±10%, 60 Hz <sup>1)</sup>	<b>960 181V</b>	<b>960 211V</b>
with single phase motor and integrated gas ballast valve 200 – 240 V ±10%, 50/60 Hz	<b>960 185V</b>	-
230 V ±10%, 50/60 Hz	-	<b>960 215V</b>
100 V -15% and 100 V +10%, 50/60 Hz	<b>960 184V</b>	-
110 – 115 V ±10% and 220 – 230 V ±10%, 50/60 Hz (switchable manually)	<b>960 186V</b>	-
Other voltages/frequencies	<b>upon request</b>	<b>upon request</b>
Filling with special oil	<b>upon request</b>	<b>upon request</b>
<b>SOGEVAC SV 16 DI</b> with UL/CSA world three-phase motor and integrated gas ballast valve 200 – 240 V ±10% and 380 – 415 V ±10%, 50 Hz / 200 – 240 V ±10% and 380 – 460 V ±10%, 60 Hz <sup>1)</sup>	<b>960 191V3001</b>	-
with single phase motor and integrated gas ballast valve 200 – 240 V ±10%, 50/60 Hz	<b>960 195V3001</b>	-
100 V -15% and 100 V +10%, 50/60 Hz	<b>960 194V3001</b>	-
110 – 115 V ±10% and 220 – 230 V ±10%, 50/60 Hz (switchable manually)	<b>960 196V3001</b>	-
<b>Accessories</b>		
Exhaust filter monitoring gauge, mechanical G 3/4" <sup>2), 3)</sup>	<b>951 93</b>	<b>951 93</b>
Temperature switch conversion kit with plug, for three-phase version only <sup>2), 3)</sup>	<b>upon request</b>	<b>upon request</b>
<b>Spare Parts</b>		
Exhaust filter cartridge AFE	<b>712 32 023</b>	<b>712 32 023</b>
Maintenance kit (filter, O-Ring, filling plug)	<b>EK 971 473 420</b>	<b>EK 971 473 420</b>
Seal kit FPM (FKM) SV 16 D / SV 25 D	<b>EK 971 473 430</b>	<b>EK 971 473 430</b>
Repair kit complete SV 16 D / SV 25 D	<b>EK 971 473 440</b>	<b>EK 971 473 440</b>

<sup>1)</sup> Pumps are delivered in high voltage connection.

For an operation at low voltage, the connections at motor terminal board must be changed

<sup>2)</sup> Please indicate when ordering a pump

<sup>3)</sup> Can be retrofitted

# SOGEVAC SV 25 B



SOGEVAC SV 25 B

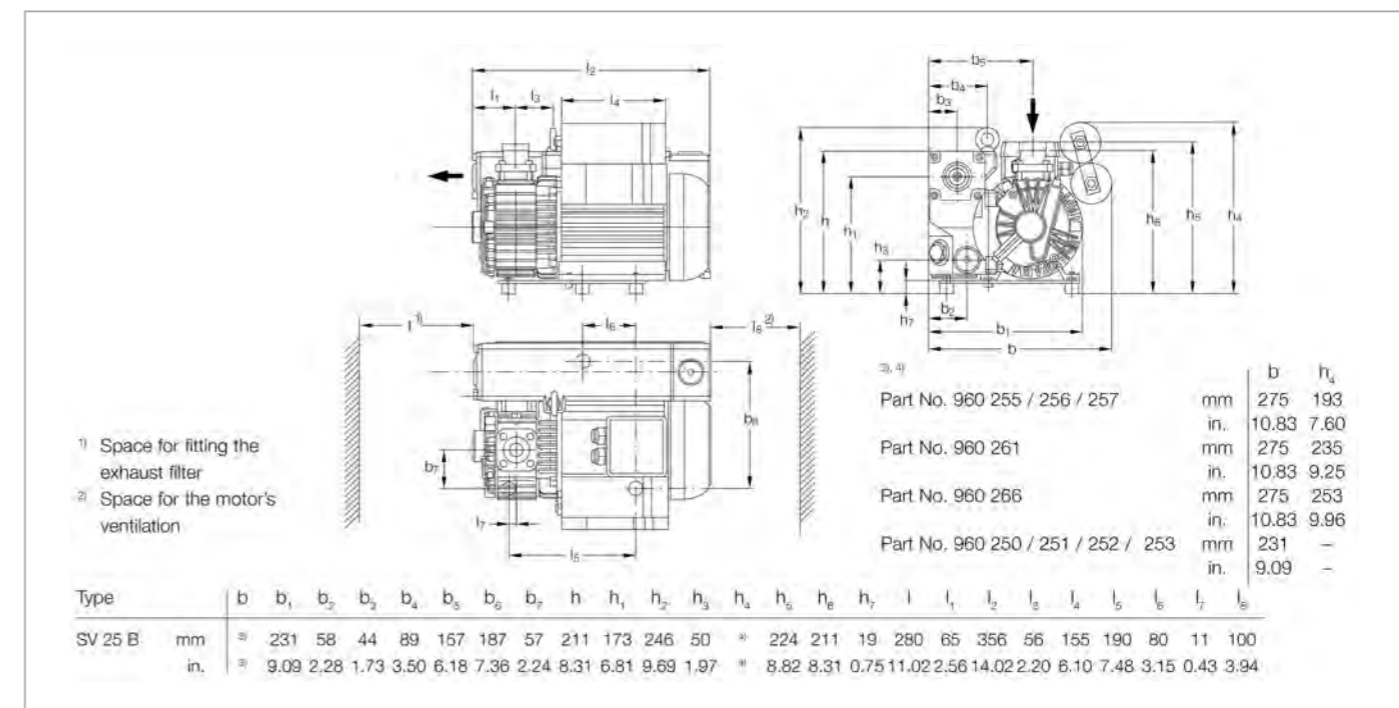

Dimensional drawing for the SOGEVAC SV 25 B

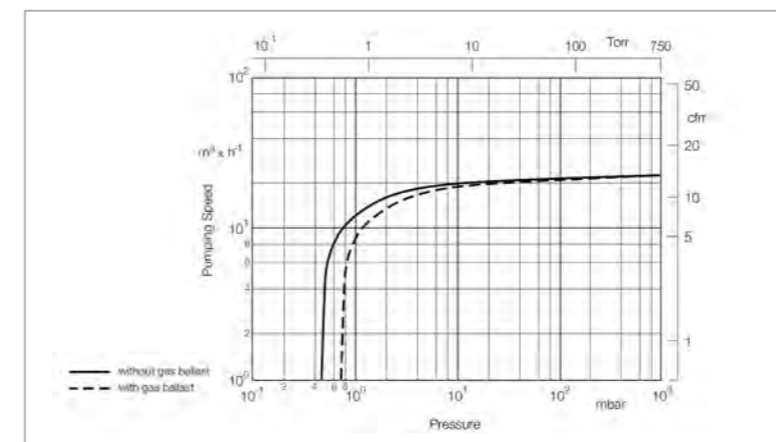

Pumping speed characteristics of the SOGEVAC SV 25 B at 50 Hz  
(60 Hz curves at the end of the chapter)

**Technical Data**

		<b>SOGEVAC SV 25 B</b>	
		<b>50 Hz</b>	<b>60 Hz</b>
Nominal speed <sup>1)</sup>	m <sup>3</sup> /h (cfm)	26.0 (15.3)	31.0 (18.3)
Pumping speed <sup>1)</sup>	m <sup>3</sup> /h (cfm)	22.5 (13.3)	25.0 (14.7)
Ultimate total pressure without gas ballast <sup>1)</sup>	mbar (Torr)	≤ 0.5 (≤ 0.4)	
Ultimate total pressure with gas ballast <sup>1)</sup>	mbar (Torr)	≤ 0.8 (≤ 0.6)	
Water vapor tolerance <sup>1)</sup>	mbar (Torr)	10.0 (7.5)	
Water vapor capacity	g/h (qt/hr)	85 (0.09)	100 (0.11)
Oil capacity	l (qt)	0.5 (0.53)	
Noise level <sup>2)</sup>	dB(A)	64	67
Admissible ambient temperature	°C (°F)	12 to 40 (54 to 104)	
Motor power	kW (hp)	0.9 (1.2)	1.1 (1.5)
Nominal speed	min <sup>-1</sup> (rpm)	3000 (3000)	3600 (3600)
Type of protection	IP	55-F	
Weight (with oil filling)	kg (lbs)	26 (57.4) [three-phase] 27 (60.0) [single-phase]	
Dimensions (L x W x H)	mm (in.)	315 x 281 x 199 (12.4 x 11.06 x 7.83)	
Connections <sup>3)</sup>			
Intake <sup>4)</sup>	G or NPT	3/4" + 1/2"	
Exhaust	G or NPT	3/4"	

**Ordering Information**

		<b>SOGEVAC SV 25 B</b>	
		<b>50 Hz</b>	<b>60 Hz</b>
		<b>Part No.</b>	
SOGEVAC SV 25 B with three-phase motor, without gas ballast 200-240/346-415 V, 50 Hz and 200-277/346-480 V, 60 Hz (CEI)		<b>960 250</b>	
with three-phase motor, with permanent gas ballast 200-240/346-415 V, 50 Hz and 200-277/346-480 V, 60 Hz (CEI)		<b>960 251</b>	
200-240/346-415 V, 50 Hz and 200-277/346-480 V, 60 Hz (CEI), NPT flanges		<b>960 253</b>	
with single-phase motor, without gas ballast 230 V, 50/60 Hz (CEI)		<b>960 255</b>	
with single-phase motor, with permanent gas ballast 230 V, 50/60 Hz (CEI)		<b>960 256</b>	
230 V, 50/60 Hz, NPT flanges (CEI)		<b>960 257</b>	
110-120 V, 60 Hz		<b>upon request</b>	
100 V, 50/60 Hz		<b>upon request</b>	
Other voltages/frequencies <sup>5)</sup>		<b>upon request</b>	
Filling with special oil		<b>upon request</b>	
<b>Accessories</b>			
Exhaust filter cartridge AFE SV25B		<b>714 16 340</b>	
<b>Spare Parts</b>			
Maintenance kit		<b>971 423 450</b>	
Repair kit		<b>971 423 100</b>	
Seal kit FPM (FKM)		<b>714 19 490</b>	

<sup>1)</sup> To DIN 28 400 and following numbers

<sup>2)</sup> Operated at the ultimate pressure without gas ballast, free-field measurement at a distance of 1 m (3.5 ft)

<sup>3)</sup> Pumps with European and Japanese motors have G, pumps with NEMA motors have NPT

<sup>4)</sup> 1/2" adapter supplied. Basic port is 3/4"

<sup>5)</sup> Please indicate when ordering a pump

Materials (materials in contact with the process gas) Steel cast iron, Aluminium, Bronze, FPM (FKM), Glass, Polyamid 6.6, Filter material, (Polymers, Paper) Epoxy resin and Glass fibre

# SOGEVAC SV 40 B / SV 65 B



SOGEVAC SV 65 B

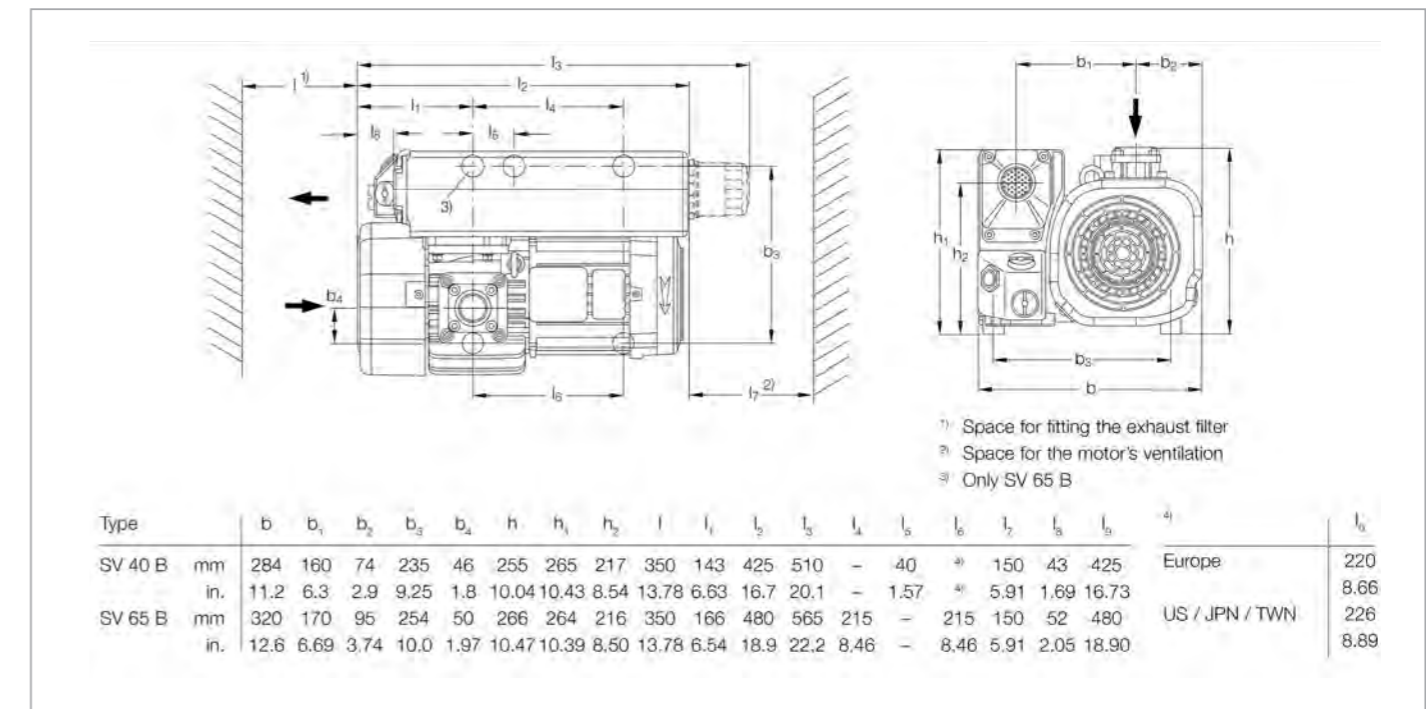

Dimensional drawing for the SOGEVAC SV 40 B and SV 65 B with standard motor, European version

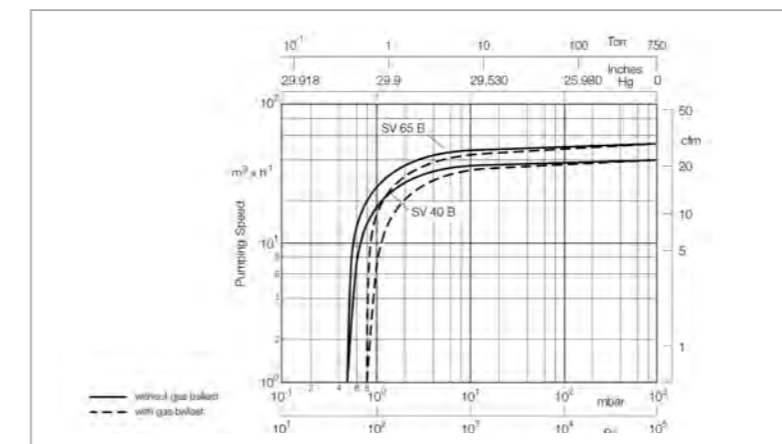

Pumping speed characteristics of the SOGEVAC SV 40 B and SV 65 B at 50 Hz (60 Hz curves at the end of the chapter)

## Technical Data

		SOGEVAC SV 40 B		SOGEVAC SV 65 B	
		50 Hz	60 Hz	50 Hz	60 Hz
Nominal speed <sup>1)</sup>	m <sup>3</sup> /h (cfm)	44.0 (25.9)	53.0 (31.2)	59.0 (34.8)	71.0 (41.8)
Pumping speed <sup>1)</sup>	m <sup>3</sup> /h (cfm)	38.5 (22.7)	47.0 (27.7)	54.0 (31.8)	64.0 (37.7)
Ultimate total pressure without gas ballast <sup>1)</sup>	mbar (Torr)	≤ 0.5 (≤ 0.4)			
Ultimate total pressure <sup>1)</sup> with standard gas ballast <sup>2)</sup> with small gas ballast <sup>2)</sup>	mbar (Torr)	≤ 1.5 (≤ 1.1)			
	mbar (Torr)	≤ 0.8 (≤ 0.6)			
Water vapor tolerance <sup>1)</sup> with standard gas ballast <sup>2)</sup> with small gas ballast <sup>2)</sup>	mbar (Torr)	30.0 (22.5)			
	mbar (Torr)	10.0 (7.5)			
Water vapor capacity with standard gas ballast <sup>2)</sup> with small gas ballast <sup>2)</sup>	kg/h (qt/hr)	0.76 (0.80)	0.90 (0.95)	1.0 (1.1)0,36	1.25 (1.32)
	kg/h (qt/hr)	0.28 (0.30)	0.34 (0.36)	0.36 (0.38)	0.42 (0.44)
Oil capacity	l (qt)	1.0 (1.05)	1.0 (1.05)	2.0 (2.1)	2.0 (2.1)
Mean noise level <sup>3)</sup>	dB(A)	58	60	60	64
Admissible ambient temperature	°C (°F)	12 to 40 (54 to 104)			
Motor power	kW (hp)	1.1 (2.0)	1.5 (2.0)	1.5 (3.0)	1.8 (3.0)
Nominal speed	min <sup>-1</sup> (rpm)	1500 (1500)	1800 (1800)	1500 (1500)	1800 (1800)
Type of protection	IP	55-F			
Weight (with oil filling)	kg (lbs)	43 (94.9)	45 (99.3)	49 (108.2)	52 (114.8)
Dimensions (L x W x H)	mm (in.)	425 x 284 x 265 (16.7 x 11.2 x 10.4)	425 x 284 x 265 (16.7 x 11.2 x 10.4)	480 x 320 x 264 (18.9 x 12.6 x 10.4)	480 x 320 x 264 (18.9 x 12.6 x 10.4)
Connection (inside thread) <sup>4)</sup>					
	Intake Exhaust	G or NPT G or NPT	1 1/4" 1 1/4"		

<sup>1)</sup> To DIN 28 400 and following numbers

<sup>2)</sup> Ordering Information, see next page

<sup>3)</sup> Operated at the ultimate pressure without gas ballast, free-field measurement at a distance of 1 m (3.5 ft)

<sup>4)</sup> Pumps with European and Japanese motors have G, pumps with US motors have NPT

Materials (materials in contact with the process gas) Steel cast iron, Aluminium, Bronze, FPM (FKM), Glass, Polyamid 6.6, Filter material, (Polymers, Paper) Epoxy resin and Glass fibre

## Ordering Information

	SOGEVAC SV 40 B		SOGEVAC SV 65 B	
	50 Hz	60 Hz	50 Hz	60 Hz
	Part No.		Part No.	
SOGEVAC SV 40 B, SV 65 B <sup>1)</sup> with three-phase motor, without gas ballast, without oil filter 230/400 V, 50 Hz and 460 V, 60 Hz (CEI) wide range motor (CEI) <sup>2)</sup>	960 300		960 420 <sup>2)</sup>	
with three-phase motor, without gas ballast, with oil filter 230/400 V, 50 Hz und 460 V, 60 Hz (CEI)	960 302		960 402	
with three-phase motor, with small gas ballast, without oil filter 230/400 V, 50 Hz and 460 V, 60 Hz (CEI) 230/460 V, 60 Hz and 400 V, 50 Hz, NPT flanges (UL/CSA motor) <sup>3)</sup> wide range motor (CEI) <sup>2)</sup>	200 V, 50/60 Hz 960 316		-	
with three-phase motor, with small gas ballast, without oil filter 230/400 V, 50 Hz and 460 V, 60 Hz (CEI) wide range motor (CEI) <sup>2)</sup>	960 303 960 323 <sup>2)</sup>			
with three-phase motor,, with standard gas ballast, without oil filter 230/400 V, 50 Hz and 460 V, 60 Hz (CEI) 230/460 V, 60 Hz and 400 V, 50 Hz (CEI), NPT flanges (UL/CSA motor) <sup>3)</sup> wide range motor (CEI) <sup>2)</sup>	960 305 960 312		960 405 960 412 960 422 <sup>2)</sup>	
200 V, 50/60 Hz			960 417	
with three-phase motor, with small gas ballast, without oil filter 230/400 V, 50 Hz and 460 V, 60 Hz (CEI) 230/460 V, 60 Hz and 400 V, 50 Hz (CEI), NPT flanges (UL/CSA motor) <sup>3)</sup> wide range motor (CEI) <sup>2)</sup>	960 307 960 314 960 324 <sup>2)</sup>		960 407 960 414 960 424 <sup>2)</sup>	
Other voltages/frequencies <sup>4)</sup>	upon request		upon request	
Filling with special oil <sup>4)</sup>	upon request		upon request	

## Accessories

Exhaust filter cartridge AFE SV40B	714 21 180	-
AFE SV65/100B	-	714 17 300

## Spare Parts

Maintenance kit	971 427 660	971 423 440
Repair kit	971 427 650	714 20 420
Seal kit FPM (FKM)	971 427 640	714 20 410
Oil filter <sup>5)</sup>	EK 960 04	EK 960 04
Oil filter bypass	712 30 570	712 30 570

<sup>1)</sup> Pumps with Europe and Japan motors in G, pumps with USA voltage in NPT

<sup>2)</sup> Wide range motor: 210-240 and 360-420 V ±5 %, 50 Hz and 210-260 and 360-460 V ±5 %, 60 Hz

<sup>3)</sup> With NEMA electrical connections without terminal board

<sup>4)</sup> Please specify when ordering pump

<sup>5)</sup> Not included in maintenance kit

# SOGEVAC SV 100 B



SOGEVAC SV 100 B

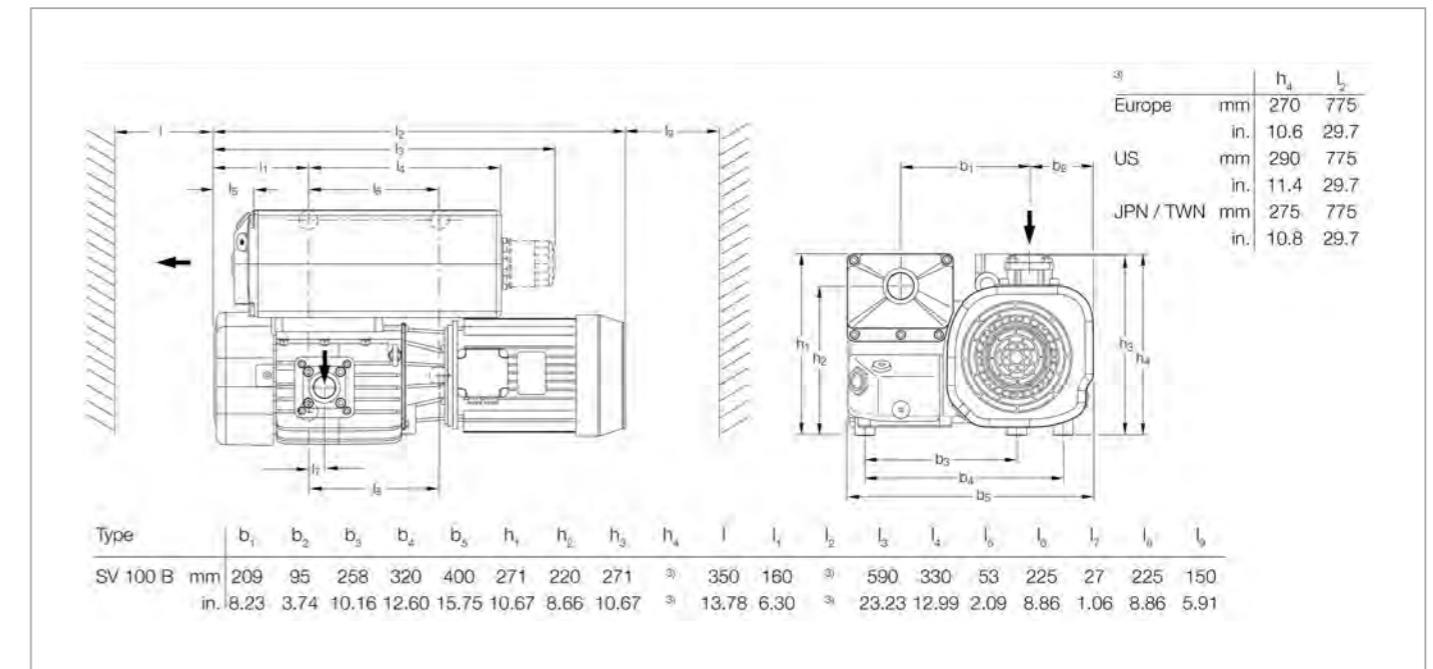

Dimensional drawing for the SOGEVAC SV 100 B

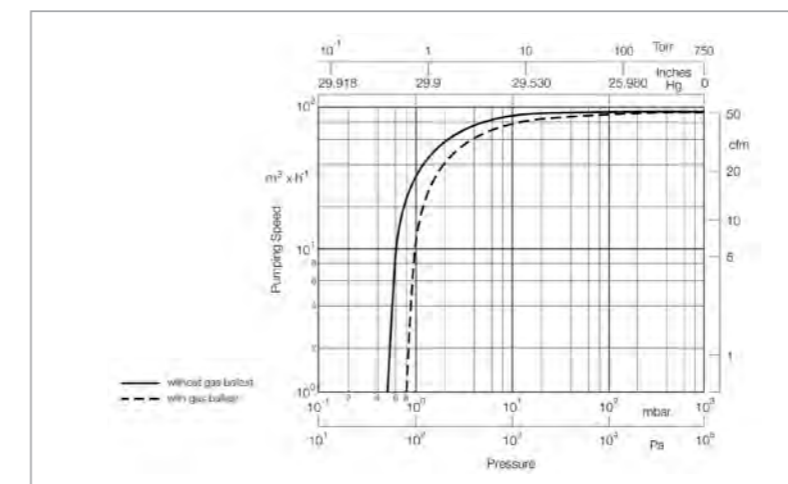

Pumping speed characteristics of the SOGEVAC SV 100 B at 50 Hz  
(60 Hz curves at the end of the chapter)

**Technical Data**

		<b>SOGEVAC SV 100 B</b>	
		<b>50 Hz</b>	<b>60 Hz</b>
Nominal speed <sup>1)</sup>	m <sup>3</sup> /h (cfm)	97.5 (57.4)	117.0 (68.9)
Pumping speed <sup>1)</sup>	m <sup>3</sup> /h (cfm)	87.5 (51.5)	105.0 (61.8)
Ultimate total pressure without gas ballast <sup>1)</sup>	mbar (Torr)	≤ 0.5 (≤ 0.4)	
Ultimate total pressure <sup>1)</sup> with standard gas ballast <sup>2)</sup>	mbar (Torr)	≤ 1.5 (≤ 1.1)	
Ultimate total pressure <sup>1)</sup> with small gas ballast <sup>2)</sup>	mbar (Torr)	≤ 0.8 (≤ 0.6)	
Water vapor tolerance <sup>1)</sup> with standard gas ballast <sup>2)</sup>	mbar (Torr)	30.0 (22.5)	
Water vapor tolerance <sup>1)</sup> with small gas ballast <sup>2)</sup>	mbar (Torr)	10.0 (7.5)	
Water vapor capacity with standard gas ballast <sup>2)</sup>	kg/h (qt/hr)	1.60 (1.69)	1.70 (1.80)
Water vapor capacity with small gas ballast <sup>2)</sup>	kg/h (qt/hr)	0.45 (0.48)	0.60 (0.63)
Oil capacity	l (qt)	2.0 (2.1)	
Mean noise level <sup>3)</sup>	dB(A)	61	64
Admissible ambient temperature	°C (°F)	12 to 40 (54 to 104)	
Motor power	kW (hp)	2.2 (3.5)	3.5 (5.0)
Nominal speed	min <sup>-1</sup> (rpm)	1500 (1500)	1800 (1800)
Type of protection	IP	55-F	
Materials (materials in contact with the gas)		Steel, cast iron, Aluminium, Bronze, FPM (FKM), Glass, Polyamid 6.6, Filter material (Polymers, Paper), Epoxy resin & Glass fibre	
Weight (with oil filling)	(lbs)	92 (203)	93 (205)
Dimensions (L x W x H)		755 x 400 x 270 (29.7 x 15.7 x 10.6)	
Europe	mm (in.)	755 x 400 x 290 (29.7 x 15.7 x 11.4)	
US	mm (in.)	755 x 400 x 275 (29.7 x 15.7 x 10.8)	
JPN / TWN	mm (in.)		
Connection (inside thread) <sup>4)</sup>			
Intake	G or NPT	1 1/4"	
Exhaust	G or NPT	1 1/4"	

<sup>1)</sup> To DIN 28 400 and following numbers

<sup>2)</sup> Ordering Information, see next page

<sup>3)</sup> Operated at the ultimate pressure without gas ballast, free-field measurement at a distance of 1 m (3.5 ft)

<sup>4)</sup> Pumps with European and Japanese motors have G, pumps with US (NEMA) motors have NPT

**Ordering Information**

		<b>50 Hz</b>	<b>60 Hz</b>
		<b>Part No.</b>	
<b>SOGEVAC SV 100 B <sup>1)</sup></b>			
with three-phase motor, without gas ballast, without oil filter	230/400 V, 50 Hz and 460 V, 60 Hz (CEI)	<b>960 500</b>	
with three-phase motor, without gas ballast, without oil filter	230/400 V, 50 Hz and 460 V, 60 Hz (CEI)		
with three-phase motor, with small gas ballast, without oil filter	230/400 V, 50 Hz and 460 V, 60 Hz (CEI)		
	230/460 V, 60 Hz and 400 V, 50 Hz (NEMA)	<b>960 511</b>	
	230/400 V, 50/60 Hz and 460 V, 60 Hz (CEI)	<b>960 521 <sup>2)</sup></b>	
with three-phase motor, with small gas ballast, with oil filter	230/400 V, 50 Hz and 460 V, 60 Hz (CEI)	<b>960 503</b>	
	230/460 V, 60 Hz and 400 V, 50 Hz (NEMA)	<b>960 523 <sup>2)</sup></b>	
with three-phase motor, with standard gas ballast, without oil filter	230/400 V, 50 Hz and 460 V, 60 Hz (CEI)	<b>960 505</b>	
	230/460 V, 60 Hz and 400 V, 50 Hz (NEMA)	<b>960 512</b>	
	230/400 V, 50/60 Hz and 460 V, 60 Hz (CEI)		
	200 V, 50/60 Hz (JIS)		
with three-phase motor, with standard gas ballast, without oil filter	230/400 V, 50 Hz and 460 V, 60 Hz (CEI)	<b>960 507</b>	
	230/460 V, 60 Hz and 400 V, 50 Hz (NEMA)	<b>960 514</b>	
	230/400 V, 50/60 Hz and 460 V, 60 Hz (CEI)	<b>960 524 <sup>2)</sup></b>	
Other voltages/frequencies <sup>2)</sup>		<b>upon request</b>	
Filling with special oil <sup>2)</sup>		<b>upon request</b>	
<b>Accessories</b>			
RUVAC adapter (WA/WS 251/501)		<b>971 448 740</b>	
Exhaust filter cartridge AFE SV65/100B <sup>3)</sup>		<b>714 17 300</b>	
<b>Spare Parts</b>			
Maintenance kit		<b>971 427 690</b>	
Repair kit		<b>971 427 680</b>	
Seal kit FPM (FKM)		<b>971 427 670</b>	
Oil filter <sup>4)</sup>		<b>EK 960 05</b>	
Oil filter bypass		<b>712 30 570</b>	

<sup>1)</sup> Pumps with European and Japanese motors have G, pumps with US voltages motors have NPT without terminal board

<sup>2)</sup> Please indicate when ordering a pump

<sup>3)</sup> 2 cartridges needed per pump

<sup>4)</sup> Not included in maintenance kit

# SOGEVAC SV 120 B



SOGEVAC SV 120 B

### Advantages to the User

- Best effective pumping speed in this class
- Good pump temperature due to the cooling coil, ideal for harsh applications. Optimal oil life time thus reached
- Wide range motor as standard
- Optimized integrated lubrication without external pipes
- Integrated oil recovery system and anti suckback valve
- Low noise level

### Typical Applications

- Oil purification
- Plastic and rubber injection presses
- Lamination
- ATEX and O<sub>2</sub> applications
- and more ...

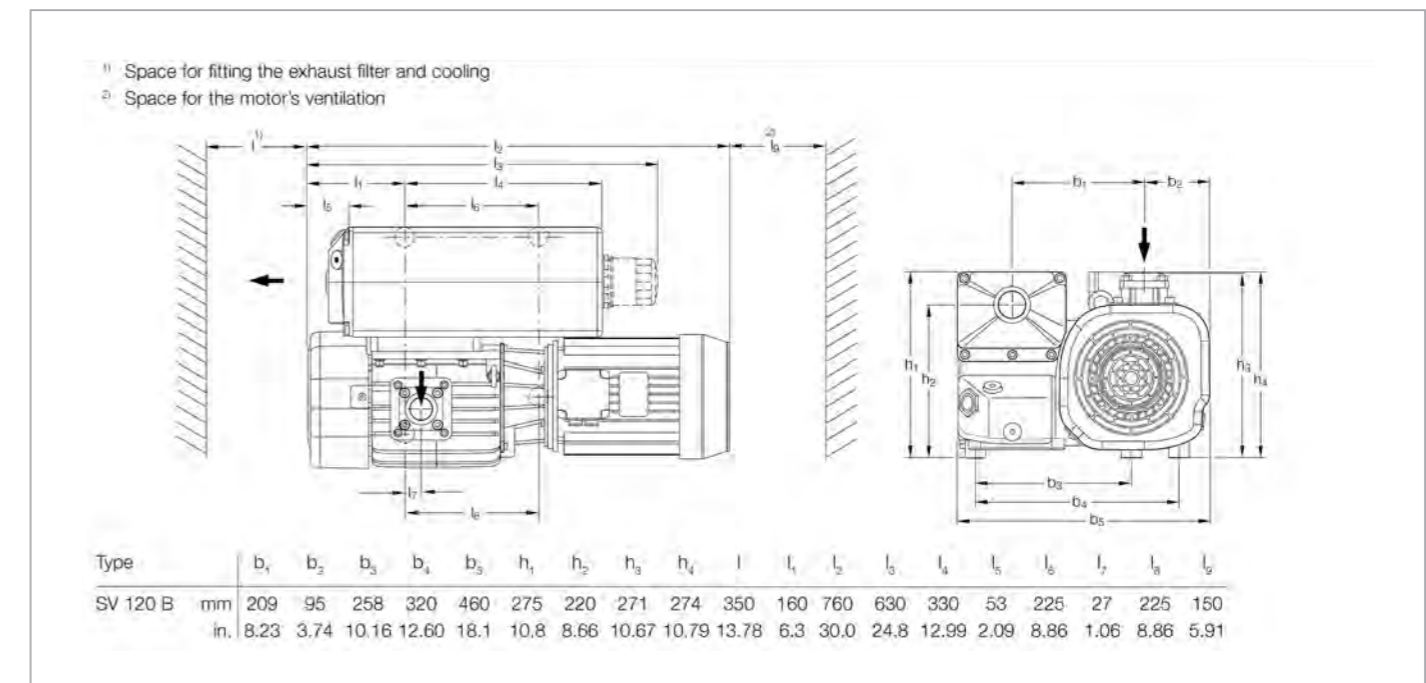

Dimensional drawing for the SOGEVAC SV 120 B

**Technical Data**

		<b>SOGEVAC SV 120 B</b>	
		<b>50 Hz</b>	<b>60 Hz</b>
Nominal speed <sup>1)</sup>	m <sup>3</sup> /h (cfm)	130 (77)	147 (86)
Pumping speed <sup>1)</sup>	m <sup>3</sup> /h (cfm)	110 (65)	122 (72)
Ultimate total pressure without gas ballast <sup>1)</sup>	mbar (Torr)	≤ 0.5 (≤ 0.4)	
Ultimate total pressure with gas ballast <sup>2)</sup>	mbar (Torr)	≤ 1.5 (≤ 1.1)	
Water vapor tolerance <sup>1)</sup> with standard gas ballast <sup>2)</sup>	mbar (Torr)	30.0 (22.5)	
Water vapor capacity with standard gas ballast <sup>2)</sup>	kg/h (qt/hr)	1.60 (1.69)	1.70 (1.80)
Mean noise level <sup>3)</sup>	dB(A)	61	64
Admissible ambient temperature	°C (°F)	12 to 40 (54 to 104)	
Motor power (with IEC Euro (NEMA) motor)	kW (hp)	2.4 (3.3)	3.2 (4.4)
Mains voltage and frequency 3 ~ motor		220–230 and 380–400 V ±10 %, 50 Hz 230 and 400–460 V ±10 %, 60 Hz	
Nominal speed	min <sup>-1</sup> (rpm)	1500 (1500)	1800 (1800)
Type of protection	IP	55-F	
Leak rate	mbar x l/s	≤ 1 x 10 <sup>-3</sup>	
Materials (materials in contact with the gas)		Steel, cast iron, Aluminium, Bronze, FPM (FKM), Glass, Polyamid 6.6, Filter material (Polymers, Paper), Epoxy resin & Glass fibre	
Oil capacity	l (qt)	2.0 (2.1)	
Weight (with oil filling)	(lbs)	94 (207)	
Dimensions (L x W x H)	mm (in.)	755 x 400 x 290 (29.7 x 15.7 x 11.4)	
Connection (inside thread) <sup>4)</sup>			
Intake	G or NPT	1 1/4"	
Exhaust	G or NPT	1 1/4"	

<sup>1)</sup> To DIN 28 400 and following numbers

<sup>2)</sup> Ordering Information, see next page

<sup>3)</sup> Operated at the ultimate pressure without gas ballast, free-field measurement at a distance of 1 m (3.5 ft)

<sup>4)</sup> Pumps with European and Japanese motors have G, pumps with US (NEMA) motors have NPT

**Ordering Information**

		<b>50 Hz</b>	<b>60 Hz</b>
		<b>Part No.</b>	
<b>SOGEVAC SV 120 B <sup>1)</sup></b>			
with three-phase motor			
230/400 V ±10%, 50 Hz			
and 230/400/460 V ±10%, 60 Hz			
without gas ballast, without oil filter		<b>960 550 V (upon request)</b>	
with small gas ballast, without oil filter			
without gas ballast, with oil filter		<b>960 552 V (upon request)</b>	
with small gas ballast, with oil filter			
with standard gas ballast, without oil filter		<b>960 572</b>	
with standard gas ballast, with oil filter		<b>960 557</b>	
Other voltages/frequencies <sup>2)</sup>		<b>upon request</b>	
Filling with special oil <sup>2)</sup>		<b>upon request</b>	
<b>Accessories</b>			
RUVAC adapter (WA/WS 251/501)		<b>971 448 740</b>	
Exhaust filter cartridge AFE SV65/100B <sup>3)</sup>		<b>714 17 300</b>	
<b>Spare Parts</b>			
Maintenance kit		<b>971 427 690</b>	
Repair kit		<b>EK 971 445 151</b>	
Oil filter <sup>4)</sup>		<b>EK 960 05</b>	
Oil filter bypass		<b>712 30 570</b>	

<sup>1)</sup> Pumps with European and Japanese motors have G, pumps with US voltages motors have NPT without terminal board

<sup>2)</sup> Please indicate when ordering a pump

<sup>3)</sup> 2 cartridges needed per pump

<sup>4)</sup> Not included in maintenance kit

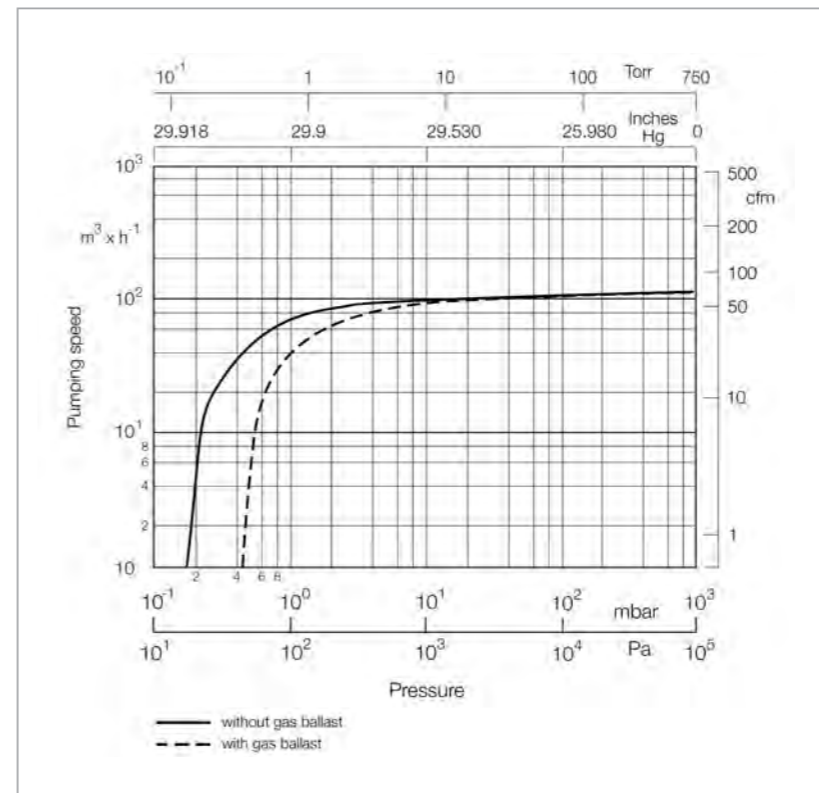

Pumping speed characteristics of the SOGEVAC SV 120 B at 50 Hz (60 Hz curves at the end of the chapter)

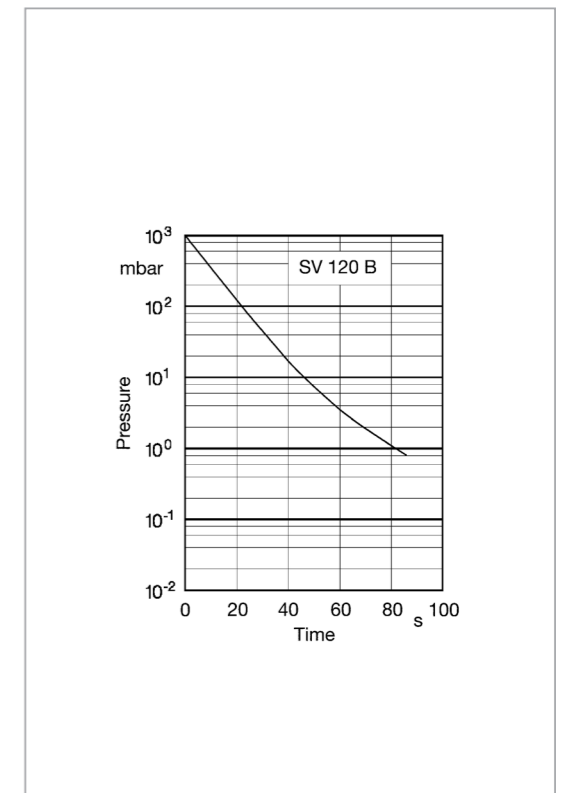

Pump-down characteristics of a 300 l vessel at 50 Hz

# SOGEVAC SV 220 B



SOGEVAC SV 220 B

### Advantages to the User

- Hygienic design
- Quick cycle times: SOGEVAC 220 B provides a very high pumping speed at all pressures
- Ideal for harsh applications:
  - Excellent ultimate pressure
  - Low pump temperature;
  - optimal oil lifetime
  - Optimized integrated lubrication
  - Yellow metal free as standard
- Excellent CoO: Integrated exhaust filters with low oil emissions
- Comfortable use: low and nice noise level
- Adapted to your needs: variant concept with many retrofittable accessories

### Typical Applications

- Coating systems and load locks
- Food packaging and processing
- Oil purification
- Plastic and rubber injection presses
- Heat treatment / Metallurgy
- Lamination
- ATEX Cat 2 or 3

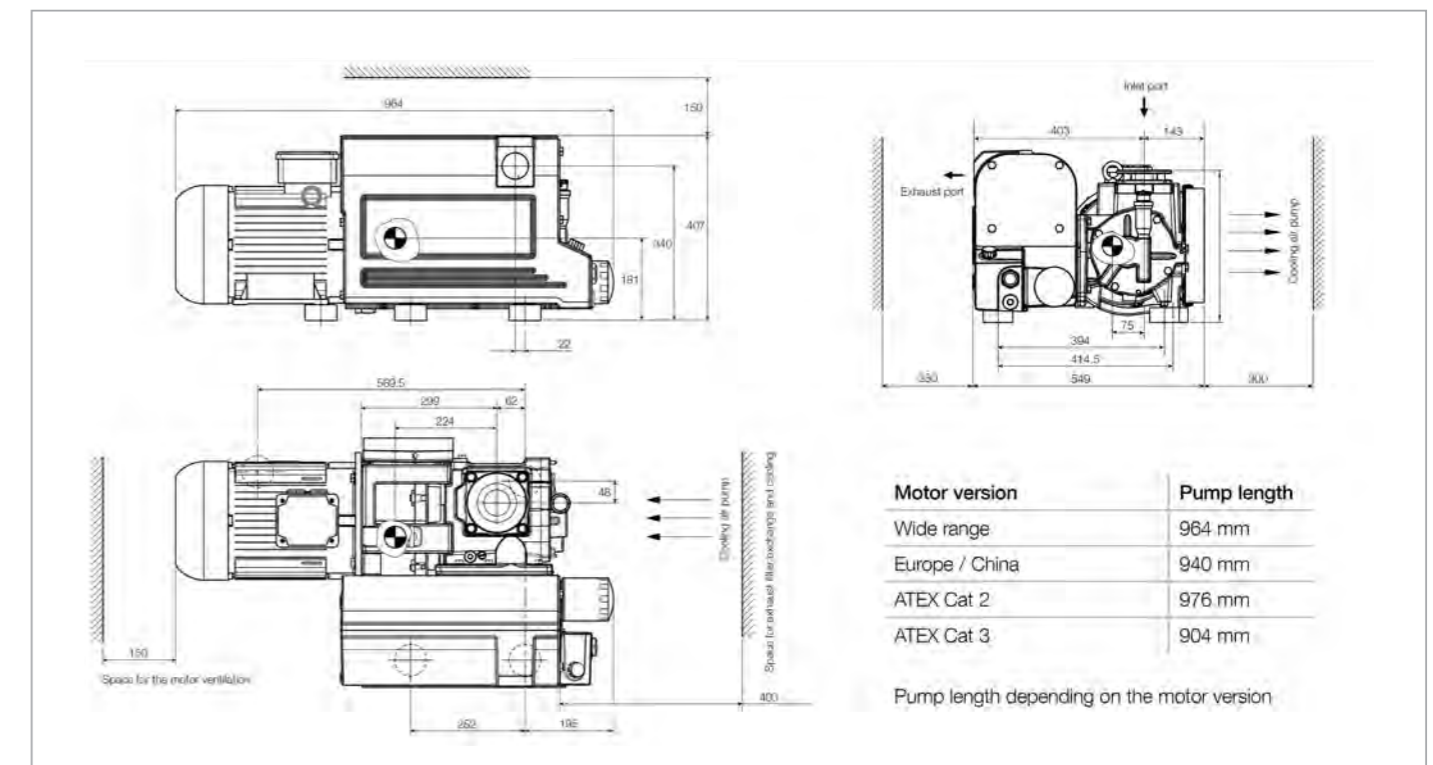

Dimensional drawing for the SOGEVAC SV 220 B

**Technical Data**
**SOGEVAC SV 220 B**

		50 Hz	60 Hz
Nominal speed <sup>1)</sup>	m <sup>3</sup> /h (cfm)	200 (117,7)	240 (141.3)
Pumping speed <sup>1)</sup>	m <sup>3</sup> /h (cfm)	179 (105.3)	214 (126)
Ultimate total pressure without gas ballast <sup>1)</sup>	mbar (Torr)	$\leq 8 \times 10^{-2}$ ( $\leq 6 \times 10^{-2}$ )	
Ultimate total pressure with standard gas ballast electromagnetic, permanent or ATEX 7 Nm <sup>3</sup> /h <sup>1)</sup>	mbar (Torr)	$\leq 0.7$ ( $\leq 0.5$ )	
Ultimate total pressure with big gas ballast 18 Nm <sup>3</sup> /h <sup>2)</sup>	mbar (Torr)	$\leq 4.0$ ( $\leq 3.0$ )	
Water vapor tolerance <sup>1)</sup> with gas ballast 7 Nm <sup>3</sup> /h <sup>2)</sup>	mbar (Torr)	10 (7.6)	10 (7.6)
Water vapor capacity with gas ballast 7 Nm <sup>3</sup> /h <sup>2)</sup>	kg/h (qt/hr)	1.7 (1.8)	2.0 (2.1)
Water vapor tolerance <sup>1)</sup> with big gas ballast 18 Nm <sup>3</sup> /h <sup>2)</sup>	mbar (Torr)	35 (27)	40 (30)
Water vapor capacity with gas ballast 7 Nm <sup>3</sup> /h <sup>2)</sup>	kg/h (qt/hr)	4.2 (4.4)	6.3 (6.6)
Noise level <sup>3)</sup>	dB(A)	69	73
Admissible ambient temperature	°C (°F)	12 to 40 (54 to 104)	
Motor power	kW (hp)	4.5 kW (6 hp at 50 Hz and 4.8 kW (6.5 hp) at 60 Hz	
Mains voltage standard IEC three-phase motor	V	220 - 230 - 240 /380 - 400 - 415 V $\pm$ 10%, 50 Hz and 440 - 460V $\pm$ 10%, 60 Hz - IE3 for other motors please contact Leybold	
Nominal speed	min <sup>-1</sup> (rpm)	1470 (1470)	1765 (1765)
Type of protection	IP	55	
Leak rate	mbar x l/s	$\leq 1 \times 10^{-3}$	
Materials (materials in contact with the process gas)		Steel, cast iron, Aluminium, Bronze, FPM (FKM), Glass, Polyamid 6.6, Filter material (Polymers, Paper), Epoxy resin & Glass fibre	
Oil capacity	l (qt)	7.5 (7.8)	
Weight (with oil filling)	kg (lbs)	180 (396)	
Dimensions (L x W x H)	mm (in.)	tbd	
Connection (inside thread) <sup>4)</sup>			
Intake	G or NPT	2"	
Exhaust	G	2"	

<sup>1)</sup> To DIN 28 400 and following numbers

<sup>2)</sup> Ordering Information see Chapter "Accessories"

<sup>3)</sup> Operated at the ultimate pressure without gas ballast, free-field measurement at a distance of 1 m (3.5 ft)

<sup>4)</sup> Pumps have G threads, NPT screw-in adapters available

**Ordering Information**
**SOGEVAC SV 220 B**

	50 Hz	60 Hz
	<b>Part No.</b>	
SOGEVAC SV 220 B <sup>1)</sup> with oil filter and mineral oil with manual gas ballast up to 7 Nm <sup>3</sup> /h air cooled with IEC three-phase motor, 220 - 230 - 240 /380 - 400 - 415 V $\pm$ 10%, 50 Hz and 440 - 460V $\pm$ 10%, 60 Hz - IE3	<b>960602V</b>	
SOGEVAC SV 220 B <sup>1)</sup> with oil filter and mineral oil with manual gas ballast up to 7 Nm <sup>3</sup> /h air cooled with IEC three-phase motor, 200 V, 220/380 V, 230/400 V, 240/415 V and 200 V, 220/380 V, 230/400 V, 440 V, 460 V, 60Hz - IE3	<b>960617V</b>	

<sup>1)</sup> Pumps with European and Japanese motors have G threads, IEC motors (Europe) 50/60 Hz have IP 55, NEMA motors have TEFC without terminal board

Ordering Information

50 Hz SOGEVAC SV 220 B 60 Hz

	Part No.
<b>Accessories</b>	
Big gas ballast connection 16 KF / G1/2"	71118120V
Gas ballast filter G1/2" for big gas ballast	971442250
Big gas ballast 18 Nm <sup>3</sup> /h with G1/2" connection	9600GBB
Permanent gas ballast 16 KF	GK6704215
Electromagnetic gas ballast 16 KF (24 V DC)	GK6704190
Standard manual gas ballast	GK6703134
Exhaust filter monitoring visual gauge	95193
Exhaust filter monitoring switch	971471210
Low oil level switch, switch type (float valve eg)	EK6542106 (rear plate) and 971458110 (E&H) or 71221992V (Schlemmer)
Oil filter bypass standard and PFPE	E6543592
Oil filter bypass ATEX	E6541596
Oil filter	E6537380
Thermal switch 105 °C	971463930
Temperature sensor PT 100	E6531771
Oil drain valve G 3/4"	71235740
<b>Roots combinations:</b>	
RUVAC WA/WS(U) 501	GK971463861
RUVAC WA/WS(U) 1001	GK971456541
RUVAC WH 700	GK971463861

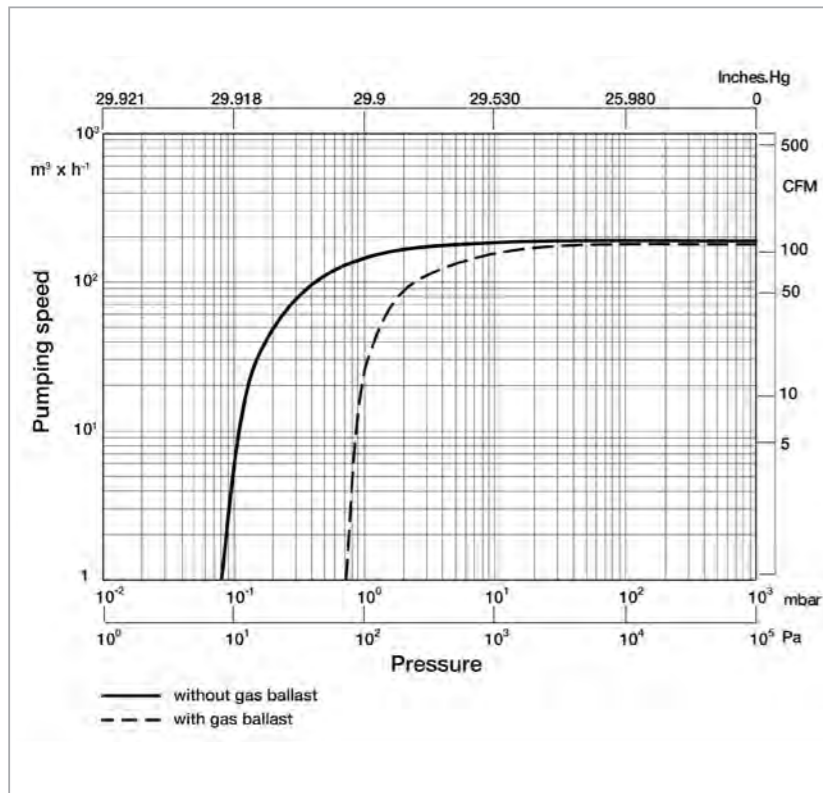

Pumping speed characteristics of the SOGEVAC SV 220 B at 50 Hz (60 Hz curves at the end of the chapter)

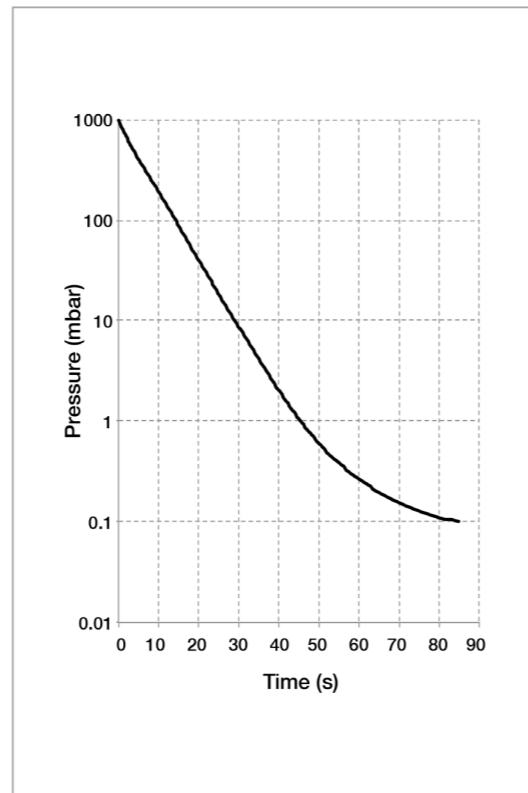

Pump-down characteristics of a 300 l vessel at 50 Hz

SOGEVAC SV 300 B and 320 B



SOGEVAC SV 300 B / SV 320 B

Advantages to the User

- SV 320 B provides highest pumping speed on the market
- Lowest pump temperature on the market: ideal for harsh applications. Optimal oil life time thus reached
- Integrated exhaust filters with low oil mist flow: long filter life time
- Optimized integrated lubrication without external pipes: yellow metal free as standard
- Integrated oil recovery system and anti-suckback valve
- Low noise level
- High reliability due to separate greased ball bearings (30.000 h life)
- Variant concept
- Best ultimate pressure
- Big oil volume for long oil life time

Typical Applications

- Coating systems and load locks
- Oil purification
- Plastic and rubber injection presses
- Heat treatment / Metallurgy
- Lamination
- ATEX and O<sub>2</sub> applications
- and more ...

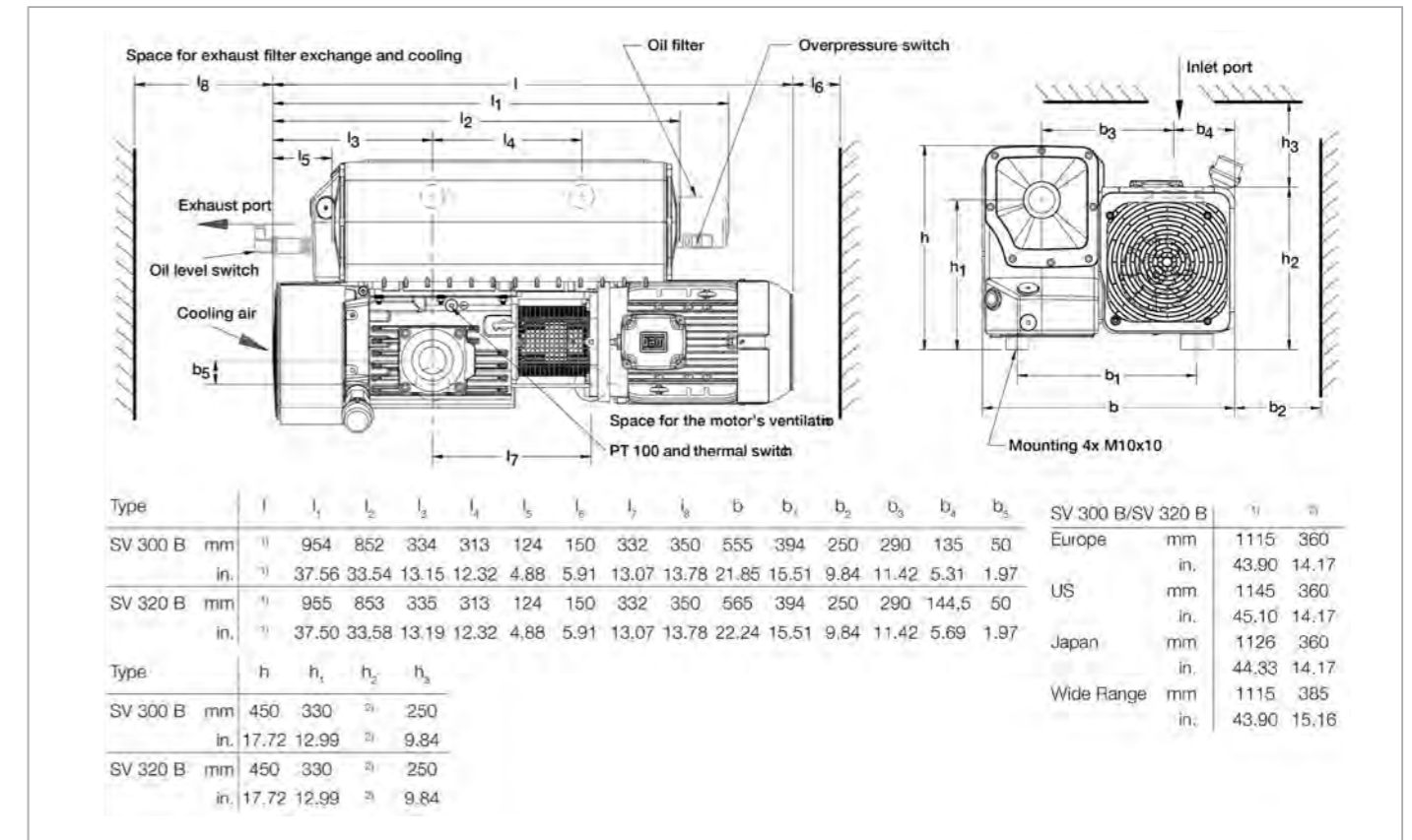

Dimensional drawing for the SOGEVAC SV 300 B/SV 320 B, European version

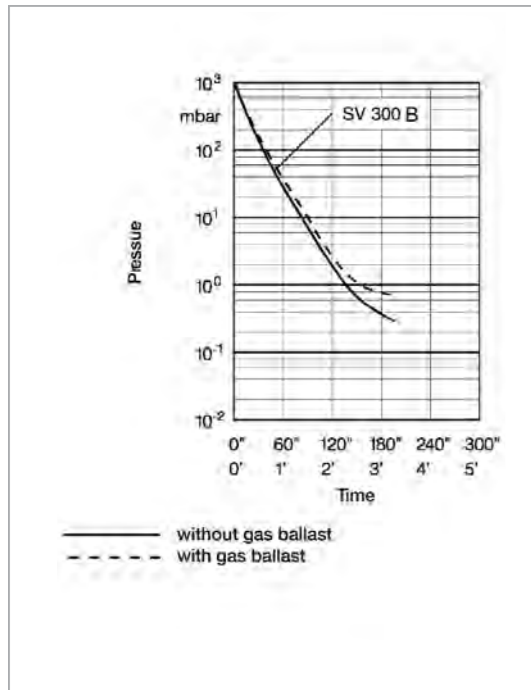

Pump-down characteristics of a 1000 l vessel at 50 Hz

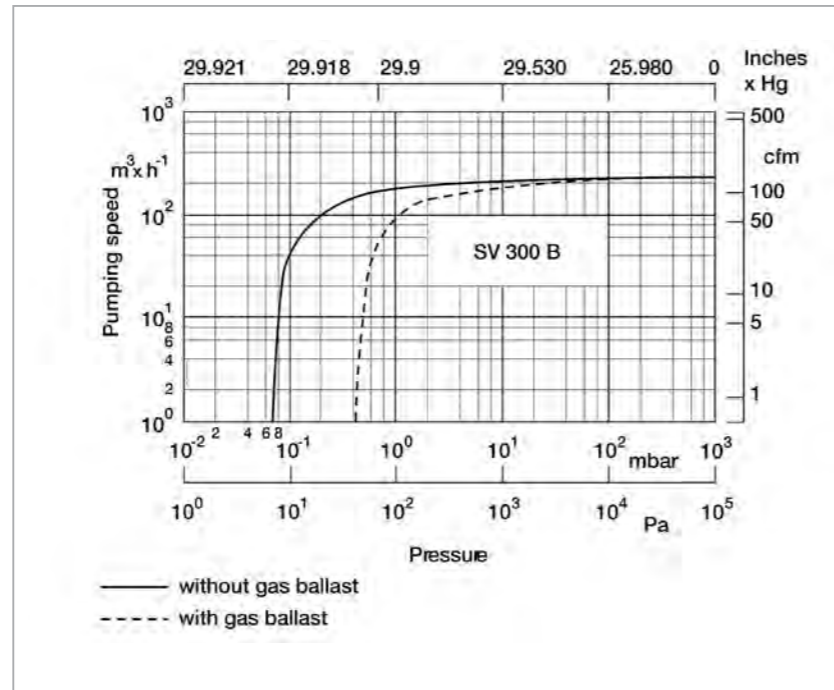

Pumping speed characteristics of the SOGEVAC SV 300 B at 50 Hz (60 Hz curves at the end of the chapter)

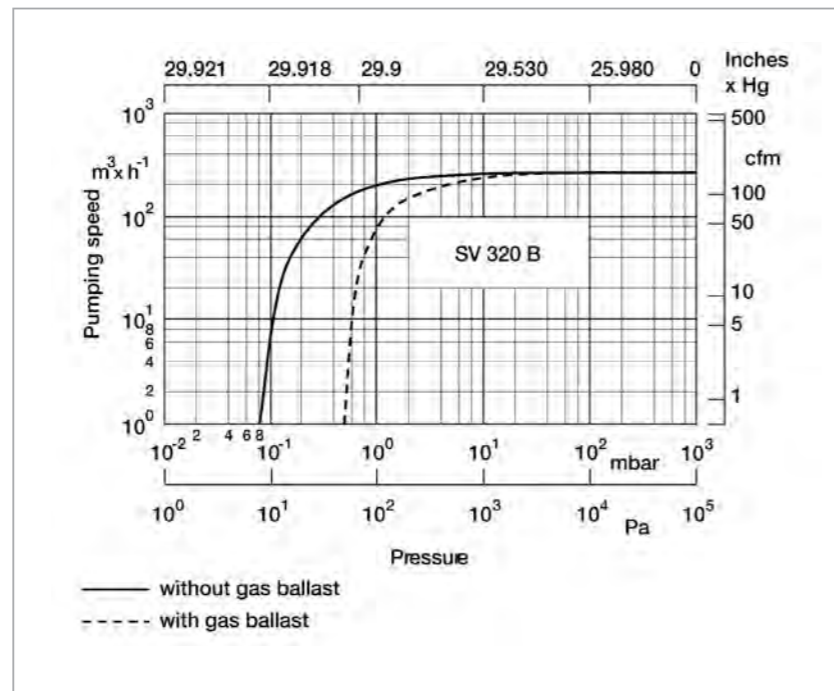

Pumping speed characteristics of the SOGEVAC SV 320 B at 50 Hz (60 Hz curves at the end of the chapter)

**Technical Data**

**SOGEVAC SV 300 B**

		<b>50 Hz</b>	<b>60 Hz</b>
Nominal speed <sup>1)</sup>	m <sup>3</sup> /h (cfm)	280 (165)	340 (200)
Pumping speed <sup>1)</sup>	m <sup>3</sup> /h (cfm)	240 (141)	290 (171)
Ultimate total pressure without gas ballast <sup>1)</sup>	mbar (Torr)	≤ 0.08 (≤ 0.06)	
Ultimate total pressure small gas ballast 4 Nm <sup>3</sup> /h <sup>1)</sup>	mbar (Torr)	≤ 0.5 (≤ 0.4)	
Ultimate total pressure with standard gas ballast 7.5 Nm <sup>3</sup> /h also for electromagnetic gas ballast 10 Nm <sup>3</sup> /h <sup>1)</sup>	mbar (Torr)	≤ 0.7 (≤ 0.5)	
Ultimate total pressure with big gas ballast 15 Nm <sup>3</sup> /h <sup>1)</sup>	mbar (Torr)	≤ 2.0 (≤ 1.5)	
Ultimate total pressure with 2 big gas ballasts 28 Nm <sup>3</sup> /h <sup>1)</sup>	mbar (Torr)	≤ 3.0 (≤ 2.3)	
Water vapor tolerance with small ballast 4 Nm <sup>3</sup> /h	mbar (Torr)	4 (3) with turbine 220 mm	5 (4) with turbine 220 mm
Water vapor capacity with small ballast 4 Nm <sup>3</sup> /h	kg/h (qt/hr)	0.4 (0.4) with turbine 220 mm	0.6 (0.6) with turbine 220 mm
Water vapor tolerance with standard gas ballast 7.5 Nm <sup>3</sup> /h also for electromagnetic gas ballast 10 Nm <sup>3</sup> /h <sup>2)</sup>	mbar (Torr)	10.0 (7.5) with turbine 220 mm 40.0 (30.0) with turbine 150 mm <sup>6)</sup>	12.0 (9.0) with turbine 220 mm 50.0 (37.5) with turbine 150 mm <sup>6)</sup>
Water vapor tolerance with big gas ballast 15 Nm <sup>3</sup> /h <sup>2)</sup>	mbar (Torr)	70.0 (52.5) with turbine 150 mm <sup>6)</sup>	
Water vapor capacity with big gas ballast 15 Nm <sup>3</sup> /h <sup>2)</sup>	kg/h (qt/hr)	11 (12) with turbine 150 mm <sup>6)</sup>	14 (15) with turbine 150 mm <sup>6)</sup>
Water vapor tolerance with 2 big gas ballasts 28 Nm <sup>3</sup> /h <sup>2)</sup>	mbar (Torr)	95 (72) with turbine 150 mm <sup>6)</sup>	
Water vapor capacity with 2 big gas ballasts 28 Nm <sup>3</sup> /h <sup>2)</sup>	kg/h (qt/hr)	15 (16) with turbine 150 mm <sup>6)</sup>	17 (18) with turbine 150 mm <sup>6)</sup>
Noise level (according to DIN 466535) <sup>3)</sup>	dB(A)	72	76
Admissible ambient temperature	°C (°F)	12 to 40 (54 to 104)	
Motor power <sup>4)</sup>	kW (hp)	5.5 (7.5)	6.3 (8.6)
Mains voltage and frequency 3 ~ motor	V	see Ordering Information	
Nominal speed	min <sup>-1</sup> (rpm)	1500 (1500)	1800 (1800)
Type of protection	IP	55	
Isolation class 3 ~ motor		F	
Leak rate	mbar x l/s	≤ 1 x 10 <sup>-3</sup>	
Oil capacity, min. / max.	l (qt)	8.5 (9.0) / 11.5 (12.2)	
Weight (with oil filling)	kg (lbs)	223 (493)	225 (497)
Connections <sup>5)</sup>			
Intake	G or NPT	2"	2"
Exhaust	G or NPT	2"	2"

<sup>1)</sup> To DIN 28 400 and following numbers

<sup>2)</sup> Ordering Information see Chapter "Accessories"

<sup>3)</sup> Operated at the ultimate pressure without gas ballast, free-field measurement at a distance of 1 m (3.5 ft)

<sup>4)</sup> Versions with NEMA motor have 10 hp motors

<sup>5)</sup> Pumps with European and Japanese motors have G, pumps with US (NEMA) motors have NPT

<sup>6)</sup> Standard turbine 220 mm. Special turbine 150 mm can be retrofitted

**Technical Data**
**SOGEVAC SV 320 B**

		50 Hz	60 Hz
Nominal speed <sup>1)</sup>	m <sup>3</sup> /h (cfm)	330 (194)	385 (227)
Pumping speed <sup>1)</sup>	m <sup>3</sup> /h (cfm)	284 (167)	330 (194)
Ultimate total pressure without gas ballast <sup>1)</sup>	mbar (Torr)	≤ 0.08 (≤ 0.06)	≤ 0.08 (≤ 0.06)
Ultimate total pressure with standard gas ballast <sup>1)</sup>	mbar (Torr)	≤ 0.7 (≤ 0.05)	≤ 0.7 (≤ 0.05)
Water vapor tolerance <sup>1)</sup> with standard gas ballast	mbar (Torr)	10 (7.6) with turbine 220 mm	12 (9.1) with turbine 220 mm
	mbar (Torr)	40 (30) with turbine 150 mm	50 (38) with turbine 150 mm
Water vapor capacity with standard gas ballast	kg/h (qt/hr)	1,5 (1.7) with turbine 220 mm	1,8 (2.2) with turbine 220 mm
	kg/h (qt/hr)	7.0 (6.4) with turbine 150 mm	9.5 (10) with turbine 150 mm
Noise level (according to DIN 466535) <sup>2)</sup>	dB(A)	70	73
Admissible ambient temperature	°C (°F)	+10 to +50 (+50 to +122)	+10 to +50 (+50 to +122)
Motor power	kW (hp)	6.0 (8.0)	7.5 (10.2)
Mains voltage and frequency 3 ~ motor	V	see Ordering Information	see Ordering Information
Weight (with oil filling)	kg (lbs)	211 (465.18)	211 (465.18)
<b>Connection</b>			
Intake, Thread	G	2"	2"
Exhaust, Thread	G	2"	2"

<sup>1)</sup> To DIN 28 400 and following numbers

<sup>2)</sup> Operated at the ultimate pressure without gas ballast, free-field measurement at a distance of 1 m (3.5 ft)

**Ordering Information**
**SOGEVAC SV 300 B**

		50 Hz	60 Hz
		<b>Part No.</b>	
SOGEVAC SV 300 B <sup>1)</sup> with oil filter with three-phase motor, without gas ballast, 230/400 V ±10%, 50 Hz and 460 V ±10%, 60 Hz (CEI) <sup>2)</sup>			<b>960 700</b>
with standard gas ballast, 230/400 V ±10%, 50 Hz and 460 V ±10%, 60 Hz (CEI) <sup>2)</sup>			<b>960 702</b>
208 V ±10%, 230/460 V ±10%, 60 Hz and 400 V ±10%, 50 Hz (NEMA) <sup>2)</sup>			<b>960 707</b>
with big gas ballast, 230/400 V ±10%, 50 Hz and 460 V ±10%, 60 Hz (CEI) <sup>2)</sup>			<b>960 703 <sup>3)</sup></b>
with Wide range motor 200 V -15% bis 230 V +10% / 380 bis 400 V ±10%, 50 Hz, CTP; 5,5 kW & 200 V -15% bis 230 V +10% / 380 bis 400 V ±10% and 460 V ±10%, 60 Hz, CTP; 6,6 kW with standard gas ballast			<b>960 717 <sup>4)</sup></b>

<sup>1)</sup> Pumps with European and Japanese motors have G, pumps with US (NEMA) have NPT

<sup>2)</sup> IEC motor (Europe) 50/60 Hz have IP 55, NEMA motor have TEFC without terminal board

<sup>3)</sup> With small 150 mm turbine

<sup>4)</sup> F and P inlet

Full option oil box with connections (bores and plugs) for

- G 3/8" for external oil filtration
- oil level sensor (vibration)
- thermostatic valve
- temperature sensor Pt100 and switch

**Note:** Further pump options upon request (for example, water cooled pumps)

**Ordering Information**

	50 Hz	60 Hz
	Part No.	
<b>Accessories</b>		
Adaptor for Roots pump <sup>1), 2)</sup>		
RUVAC 501 (BR 2)		971 463 880
RUVAC 1001 (BR 2)		971 463 890
Mounting pedestal for fitting to a Roots pump		971 456 590
Oil level monitor <sup>1), 3)</sup>		
(several types are available)	712 21 992V or 971 458 110 (yellow metal free)	
Thermal switch (105 °C) <sup>2), 3)</sup>		971 463 930
Pt100 sensor <sup>2)</sup>		971 464 020
Exhaust filter gauge, mechanical <sup>1), 2)</sup>		951 94
Exhaust filter monitoring switch, electric <sup>1), 3)</sup>		712 22 360
Manual gas ballast kit <sup>2)</sup>		
(incl. small, standard and big)		971 464 130
Gas ballast valve, electromagnetic 24 V DC <sup>1), 2)</sup>		
with end plate		971 465 380
without end plate		971 465 680
Two gas ballast valves <sup>1)</sup>		upon request
Water cooling with thermostatic valve only with all option oil casing <sup>3)</sup>		EK 971 449 111
Oil filter bypass <sup>1), 2)</sup>		712 30 570
<b>Spare Parts</b>		
Oil filter		EK 960 06
Exhaust filter cartridge (3x required)		
AFE SV 300 B – SV 750 B		971 431 120
Set of gaskets FPM (FKM) (standard)		971 464 950
Repair kit		971 464 960
Maintenance kit		971 464 970
Generator kit		
G 2"		971 447 390
NPT 2"		971 458 970
Turbine 150 mm kit <sup>2), 3)</sup>		EK 650 3 195

<sup>1)</sup> Please indicate when ordering a pump  
<sup>2)</sup> Can be retrofitted  
<sup>3)</sup> Can be retrofitted by Leybold Service

**Ordering Information**

	50 Hz	60 Hz
	Part No.	
<b>SOGEVAC SV 320 B</b>		
with three-phase motor IEC, with integrated gas ballast valve, air cooled, mineral oil 230/400 V ±10%, 50 Hz and 460 V ±10%, 60 Hz		960 722V
with integrated gas ballast valve, water cooled, mineral oil 230/400 V ±10%, 50 Hz and 460 V ±10%, 60 Hz		960 722V2002
with wide range motor, with integrated gas ballast valve, air cooled, mineral oil 200V -15% ... 230V +10% / 380 ... 400 V ±10%, 50Hz und 200V -15% ... 230V +10% / 380 ... 400 V ±10% & 460 ±10%, 60Hz		960 732V
with integrated gas ballast valve, water cooled, mineral oil 200V -15% ... 230V +10% / 380 ... 400 V ±10%, 50Hz und 200V -15% ... 230V +10% / 380 ... 400 V ±10% & 460 ±10%, 60Hz		960 732V2002
with three-phase motor IEC, with integrated gas ballast valve, air cooled, food grade oil 230/400 V ±10%, 50 Hz and 460 V ±10%, 60 Hz		960 722FP
with integrated gas ballast valve, water cooled, food grade oil 230/400 V ±10%, 50 Hz and 460 V ±10%, 60 Hz		960 722FP2002
<b>Accessories</b>		
Adaptor for Roots pump <sup>1), 2)</sup>		
RUVAC 501 (BR 2)		971 463 880
RUVAC 1001 (BR 2)		971 463 890
Mounting pedestal for fitting to a Roots pump		971 456 590
Oil level monitor <sup>1), 3)</sup>		
(several types are available)	712 21 992V or 971 458 110 (yellow metal free)	
Thermal switch (105 °C) <sup>2), 3)</sup>		971 463 930
Pt100 sensor <sup>2)</sup>		971 464 020
Exhaust filter monitoring switch, mechanical <sup>1), 2)</sup>		951 94
Exhaust filter monitoring switch, electric <sup>1), 2)</sup>		712 22 360
Manual gas ballast kit <sup>2)</sup>		
(incl. small, standard and big)		971 464 130
Gas ballast valve, electromagnetic 24 V DC <sup>1), 2)</sup>		
without end plate		971 465 680
Oil filter bypass <sup>1), 2)</sup>		712 30 570
<b>Spare Parts</b>		
Oil filter		EK 960 06
Exhaust filter cartridge (3x required)		
AFE SV 300 B – SV 750 B		971 431 120
Set of gaskets FPM (FKM) (standard)		EK96022SK
Repair kit		EK96072RES
Maintenance kit		971 464 970

<sup>1)</sup> Please indicate when ordering a pump  
<sup>2)</sup> Can be retrofitted  
<sup>3)</sup> Can be retrofitted by Leybold Service

# SOGEVAC SV 630 B/630 BF/750 B/750 BF



SOGEVAC SV 630 B

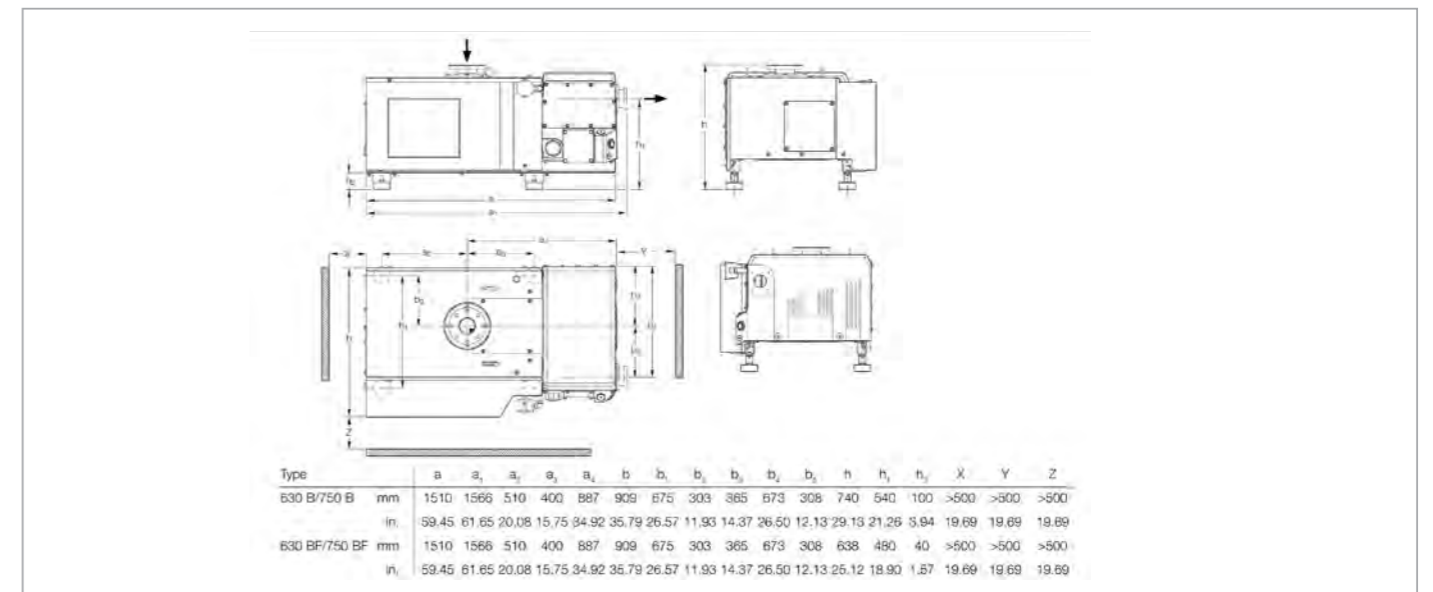

Dimensional drawing for the SOGEVAC SV 630 B, SV 630 BF, 750 B and 750 BF

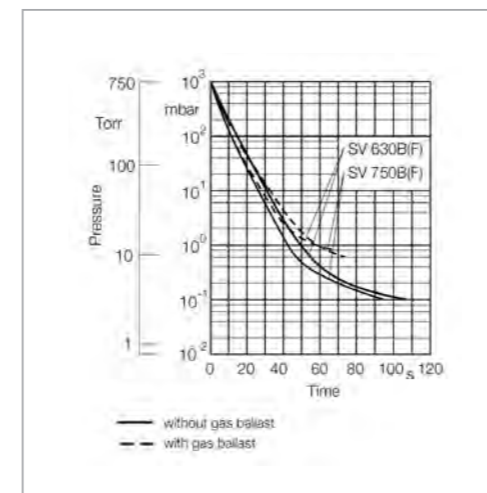

Pumpdown curve for a 1000 l vessel for 50 Hz pump operation

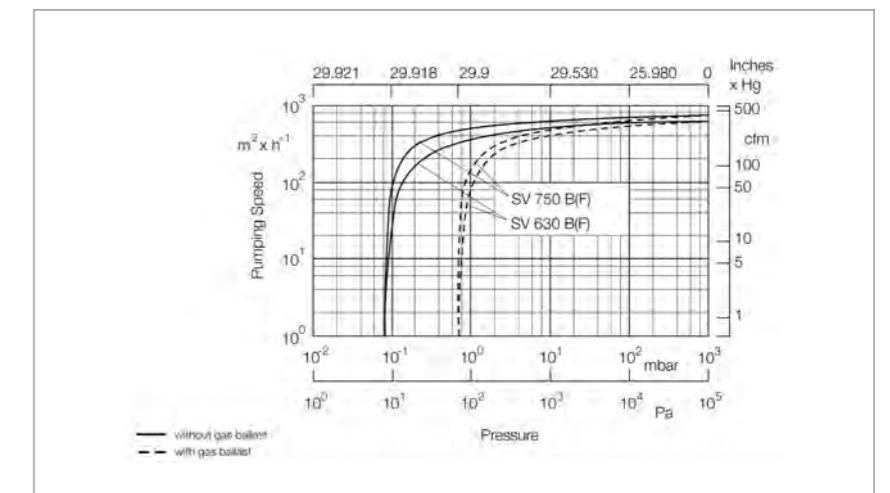

Pumping speed characteristics of the SOGEVAC SV 630 B(F) and 750 B(F) (60 Hz curves at the end of the chapter)

**Technical Data**

		SOGEVAC SV 630 B		SOGEVAC SV 630 BF		SOGEVAC SV 750 B/BF	
		50 Hz	60 Hz	50 Hz	60 Hz	50 Hz	
Nominal speed <sup>1)</sup>	m <sup>3</sup> /h (cfm)	700 (412.0)	840 (494.4)	700 (412.0)	840 (494.4)	840 (494.4)	
Pumping speed <sup>1)</sup>	m <sup>3</sup> /h (cfm)	640 (376.7)	755 (444.4)	640 (376.7)	755 (444.4)	755 (444.4)	
Ultimate total pressure without gas ballast <sup>1)</sup>	mbar (Torr)	$< 8 \times 10^{-2}$ ( $< 6 \times 10^{-2}$ )					
Ultimate total pressure with 1 gas ballast <sup>1)</sup> with 2 gas ballast valves <sup>1)</sup>	mbar (Torr)	$\leq 0,7$ ( $\leq 0.5$ )					
	mbar (Torr)	$\leq 2$ ( $\leq 1.5$ )					
Water vapor tolerance <sup>1)</sup> with 1 gas ballast <sup>1), 2)</sup> with 2 gas ballast valves <sup>1), 2)</sup>	mbar (Torr)	40.0 (30.0)	50.0 (37.5)	25.0 (18.8)	30.0 (22.5)	50.0 (37.5)	
	mbar (Torr)	60.0 (45.0)	70.0 (52.5)	35.0 (26.3)	40.0 (30.0)	70.0 (52.5)	
Max. water vapor capacity with 1 gas ballast <sup>1), 2)</sup> with 2 gas ballast valves <sup>1), 2)</sup>	kg/h (qt/hr)	17.0 (18.0)	24.0 (25.4)	11.0 (11.6)	14.0 (14.8)	24.0 (25.4)	
	kg/h (qt/hr)	26.0 (27.5)	34.0 (35.9)	15.0 (15.9)	19.0 (20.1)	34.0 (35.9)	
Controlled anti suck back valve 24	V DC	-	-	yes	yes	-	
Oil filling min. / max.	l	20 / 23					
Noise level (averaged) <sup>3)</sup>	dB(A)	72	75	72	75	75	
Admissible ambient temperature	°C (°F)	12 to 40 (54 to 104)					
Motor power	kW (hp)	15.0 (20.2)	18.5 (25.0)	15.0 (20.2)	18.5 (25.0)	18.5 (25.0)	
Nominal speed pump	min <sup>-1</sup> (rpm)	820 (820)	1000 (1000)	820 (820)	1000 (1000)	1000 (1000)	
Type of protection	IP	55-F					
Cooling		air	air	water	water	air / water	
Thermostatic valve		no	no	yes	yes	no / yes	
Temperature protection Pump Motor PTC		no	no	yes	yes	no / yes	
		no	no	yes	yes	no / yes	
Water quality	TH	-	-	4 to 8	4 to 8	-	
Water pressure, min. / max.	bar (psig)	-	-	2/8 (29/114)	2/8 (29/114)	-	
Materials (materials in contact with the gas)		Steel, cast iron, Aluminium, FPM (FKM), Glass, Polyamid 6.6, Filter material (Polymers, Paper), Epoxy resin & Glass fibre					
Net weight (with oil filling)	kg (lbs)	730 (1611)	760 (1678)	730 (1611)	760 (1678)	750 (1656)	
Dimensions (L x W x H)	mm (in.)	1510 x 909 x 740	1510 x 909 x 740	1566 x 638 x 909	1566 x 638 x 909	1510 x 909 x 740	
	(in.)	(59.45 x 35.79 x 29.13)	(59.45 x 35.79 x 29.13)	(61.65 x 25.12 x 35.79)	(61.65 x 25.12 x 35.79)	(59.45 x 35.79 x 29.13)	
Connection							
Intake	EUROPE / US	DN	100 PN 10 / 100 ISO-K Option <sup>4)</sup>	100 PN 10 / 100 ISO-K Option <sup>4)</sup>	DIN 160 Roots adapter 100 ISO-K	DIN 160 Roots adapter 100 ISO-K	100 PN 10 / 100 ISO-K Option
Exhaust	EUROPE / US	DN					

<sup>1)</sup> To DIN 28 400 and following numbers, with standard gas ballast

<sup>2)</sup> Please ask Leybold for more information

<sup>3)</sup> Operated at the ultimate pressure without gas ballast, free-field measurement at a distance of 1 m (3.5 ft)

<sup>4)</sup> 77 mm exhaust with 4 x M10 holes on 145 mm circle.

**Ordering Information**

	SV 630 B 50/60 Hz	SOGEVAC SV 630 BF 50/60 Hz	SV 750 B/BF 50 Hz
	Part No.	Part No.	Part No.
SOGEVAC SV 630 B with three-phase motor NEMA) 400 V, 50 Hz and 230/460 V, 60 Hz w/o terminal board	960 865	-	-
380/400/415/690 V, 50 Hz and 440/460 V, 60 Hz	960 863	-	-
200 V, 50 Hz (JIS) and 200 V, 60 Hz	-	-	-
SOGEVAC SV 630 BF with three-phase motor NEMA) 400 V, 50 Hz and 230/460 V, 60 Hz w/o terminal board	-	960 869	-
380/400/415/690 V, 50 Hz and 440/460 V, 60 Hz	-	960 867	-
200 V, 50 Hz (JIS) and 200 V, 60 Hz	-	960 866TE	-
SOGEVAC SV 750 B with three-phase motor NEMA) 380/400/415/690 V, 50 Hz	-	-	960 875
SOGEVAC SV 750 BF with three-phase motor NEMA) 380/400/415/690 V, 50 Hz	-	-	960 877
Other voltages/frequencies	upon request	upon request	upon request
Filling with special oil	upon request	upon request	upon request

## Ordering Information

	SV 630 B 50/60 Hz	SOGEVAC SV 630 BF 50/60 Hz	SV 750 B/BF 50/60 Hz
	Part No.	Part No.	Part No.
<b>Accessories</b>			
Adapter for Roots pump			
RUVAC 1000	971 432 340	971 432 340	971 432 340
RUVAC 2000	971 432 350	Standard	971 432 350
RUVAC 2000	971 43 WH4400	971 43 WH4400	971 43 WH4400
Oil drain valve	711 30 114	Standard	711 30 114
Gas ballast kit			
electromagnetic, 24 V DC	971 438 170	Standard	971 438 170
Gas ballast standard manual	Standard	971 446 490	971 446 490
2nd gas ballast valve			
electromagnetic, 24 V DC	-	971 438 160	-
manual	971 438 340	-	971 438 340
Exhaust filter monitoring gauge	951 94	951 94	951 94
Oil level check	9516 252V	9516 252V	9516 252V
Temperature switch	Standard	Standard	Standard
Water cooling with thermostatic valve	Upon request	Upon request	Upon request
Intake kit DN 100 ISO-K	Standard	971 430 550	Depends of P/N, see sales text
Exhaust filter overpressure switch	712 22 360	712 22 360	712 22 360
Oil filter bypass	712 36 390	712 36 390	712 36 390
Exhaust kit DN 100 PN 10 – 100 ISO-K	971 438 540	Standard	971 438 540 for B version, standard on SV 750 BF
<b>Spare Parts</b>			
Oil filter, standard	EK 960 08	EK 960 08	EK 960 08
Exhaust filter AFE SV630/SV750B/SV300B (8 are required)	971 431 120	971 431 120	971 431 120
Intake filter element			
Paper	710 35 242	710 35 242	710 35 242
Metal	E 710 37 734	E 710 37 734	E 710 37 734
Activated charcoal	710 37 724	710 37 724	710 37 724
Polyester	712 61 508	712 61 508	712 61 508
Seal kit FPM	971 437 310	971 437 310	971 437 310
Repair kit, complete	971 437 320	971 437 320	971 437 320
Generator kit	971 437 330	971 437 330	971 437 330
Maintenance kit	971 437 340	971 437 340	971 437 340

## SOGEVAC SV 28 BI



SOGEVAC SV 28 BI

### Advantages to the User

- 1 decade better ultimate pressure compared to SOGEVAC SV 25 B
- Integrated exhaust filter
- Integrated oil recovery system and anti suckback valve
- Extremely low noise level
- High reliability
- Variant concept
- Customer specific configurations
- High pumping speed stability at low pressure
- 2 oil casings (0.5 and 1.5 l) are available. The bigger oil volume allows longer oil life times

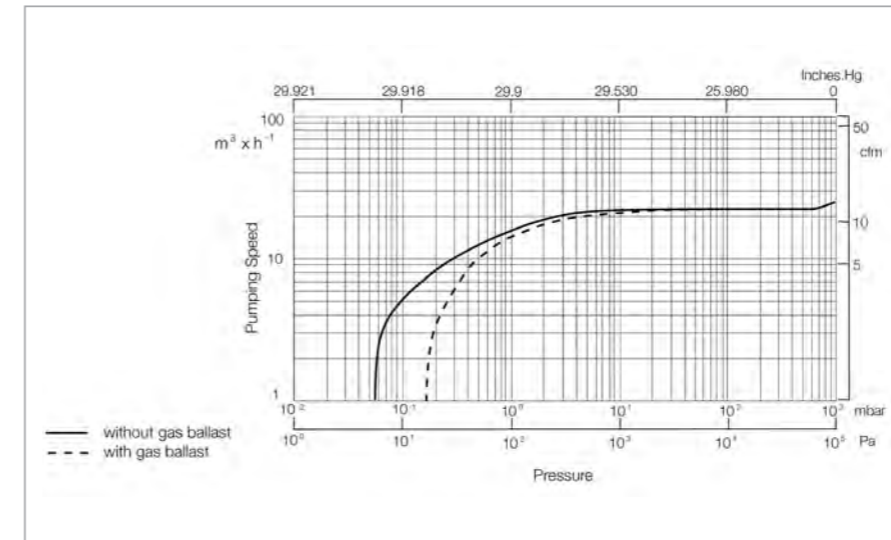

Pumping speed characteristics of the SOGEVAC SV 28 BI at 50 Hz  
(60 Hz curves at the end of the chapter)

### Typical Applications

- Mass spectrometry
- Lyophilisation
- Laboratory
- Refrigeration and air-conditioning
- Lamps and bulbs
- and more ...

**Technical Data**

**SOGEVAC SV 28 BI**

		50 Hz	60 Hz
Nominal pumping speed	m³/h (cfm)	25 (14.8)	30 (17.8)
Pumping speed (according to PNEUROP)	m³/h (cfm)	23 (13.6)	27 (15.9)
Ultimate total pressure without gas ballast	mbar (Torr)	≤ 0.05 (≤ 0.04)	
Ultimate total pressure with gas ballast	mbar (Torr)	≤ 0.5 (≤ 0.4)	
Water vapor tolerable load with gas ballast	mbar (Torr)	10.0 (7.5)	
Noise level (according to DIN 466535)			
3~ motor	dB(A)	54	57
1~ motor	dB(A)	57	60
Motor power			
3~ motor	kW (hp)	0.90 (1.2)	1.1 (1.5)
1~ motor	kW (hp)	0.75 (1.0)	0.9 (1.2)
Mains voltage and frequency 3 ~ motor		see Ordering Information	
3~ motor	V	see Ordering Information	
1~ motor	V	see Ordering Information	
Rated rotational speed	min <sup>-1</sup> (rpm)	1500 (1500)	1800 (1800)
Type of protection	IP	55-F	
Leak rate	mbar x l/s	≤ 1 x 10 <sup>-3</sup>	
Oil capacity (depending on Part No.)	l (qt)	1.5 (1.59)	
Net weight (with oil filling) dependent of oil casing and motor	kg (lbs)	34 (75) to 37 (82)	
Connections			
Intake	DN	25 ISO-KF	
Exhaust	DN	25 ISO-KF	

**Ordering Information**

**SOGEVAC SV 28 BI**

50 Hz

60 Hz

	Part No.
SOGEVAC SV 28 BI with wide range three-phase motor 170–253 / 294–440 V, 50 Hz and 170–292 / 294–506 V, 60 Hz with gas ballast, with 1.5 l oil casing	960 273
with wide range single-phase motor 180–264 V, 50/60 Hz with gas ballast, with 1.5 l oil casing	960 277
with single-phase motor (US and Japan) 100 V +10%/-15%, 50/60 Hz and 115 V +10%/-15%, 60 Hz with gas ballast, with 1.5 l oil casing	upon request
Other voltages/frequencies	upon request
Filling with special oil	upon request
<b>Accessories</b>	
Exhaust filter cartridge	714 16 340
<b>Spare Parts</b>	
Repair kit	971 462 690
Set of seals FPM (FKM)	971 462 670
Generator kit	
three-phase	971 462 620
single-phase	971 462 630
Maintenance kit	971 462 810

For further accessories see Chapter “Accessories TRIVAC” in the Catalog Part “Oil Sealed Vacuum Pumps TRIVAC”

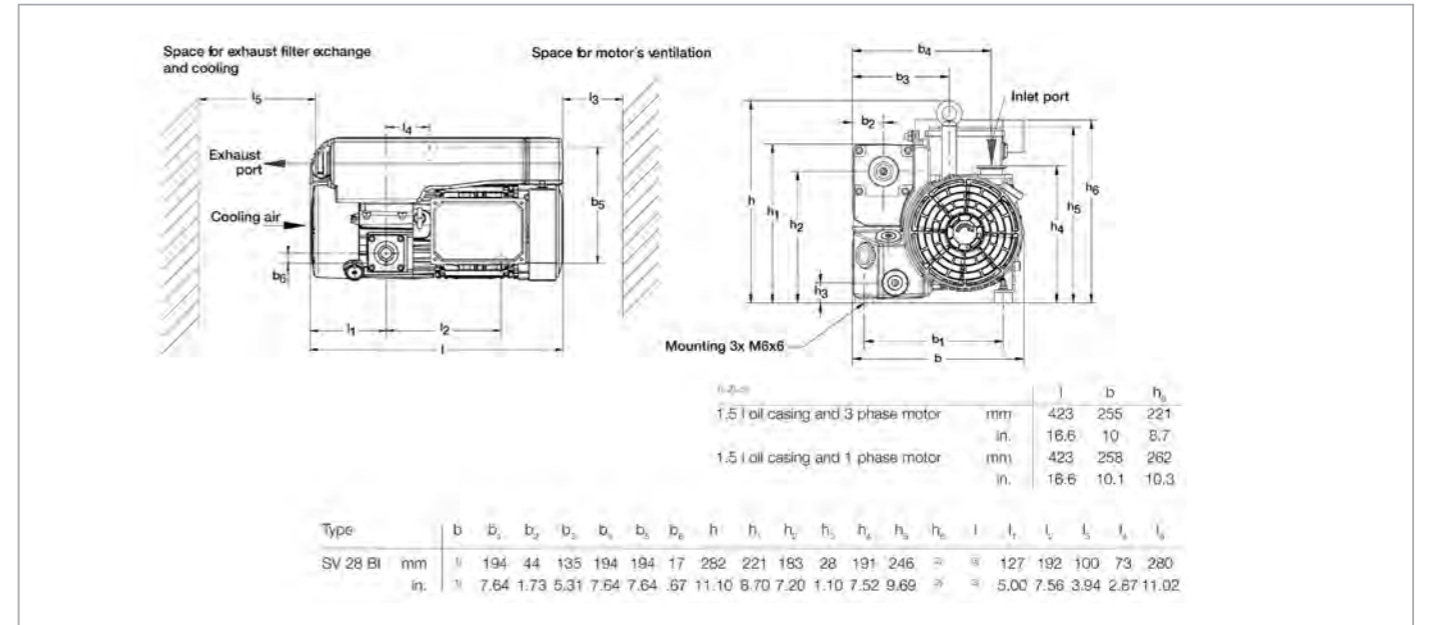

Dimensional drawing for the SOGEVAC SV 28 BI with standard single-phase motor, European version (dimensions for three-phase motor smaller)



## Technical Data

		SOGEVAC SV 40 B	
		50 Hz	60 Hz
Nominal pumping speed	m <sup>3</sup> /h (cfm)	42 (24.8)	50 (29.5)
Pumping speed (according to PNEUROP)	m <sup>3</sup> /h (cfm)	40 (23.6)	48 (28.3)
Ultimate total pressure without gas ballast	mbar (Torr)	$\leq 5 \times 10^{-2}$ ( $\leq 3.75 \times 10^{-2}$ )	
Ultimate total pressure with gas ballast	mbar (Torr)	$\leq 0.5$ ( $\leq 0.4$ )	
Water vapor tolerable load with gas ballast	mbar (Torr)	10.0 (7.5)	
Motor power	kW (hp)	1.1 (1.5)	1.3 (1.8)
Mains voltage and frequency	V	see Ordering Information	
Rated rotational speed	min-1 (rpm)	1500 (1500)	1800 (1800)
Type of protection	IP	55-F	
Leak rate	mbar x l/s	$\leq 1 \times 10^{-3}$	
Oil capacity	l (qt)	1.0 (1.1)	
Net weight (with oil filling)		43 (94.9)	45 (99.3)
Connections intake	DN	40 ISO-KF	
Connections exhaust	DN	40 ISO-KF	

## Ordering Information

		SOGEVAC SV 28 BI	
		50 Hz	60 Hz
		Part No.	
SOGEVAC SV 40 BI with three-phase motor			
with small gas ballast 230/400 V, 50 Hz and 460 V, 60 Hz		960 331	
Other voltages/frequencies or single-phase motors		upon request	
Filling with special oil		upon request	
<b>Accessories</b>			
Exhaust filter cartridge AFE SV40B I		971 471 470	
<b>Spare Parts</b>			
Repair kit		971 443 150	
Set of seals		971 427 640	
Vacuum generator with gas ballast		971 443 160	
Vacuum generator without gas ballast		971 443 170	
Maintenance kit		971 427 660	

For further accessories see Chapter "Accessories TRIVAC" in the Catalog Part "Oil Sealed Vacuum Pumps TRIVAC"

# Pumps Prepared with PFPE for Use with Oxygen

## Application

As soon as oxygen is being pumped at concentrations exceeding 20% (atmospheric air) the SOGEVAC pump needs to be prepared especially for such operation.

## Safety Precautions

As standard, the pumps are equipped with FPM (FKM) seals and an oil filter bypass. Before assembly, all parts are degreased and the pumps are tested with PFPE lubricant (LVO 400). Thereafter the pumps are emptied and delivered without PFPE lubricant (LVO 400).

The pumps are supplied with special Operating Instructions (GA), Spare Parts List (ET) blue colored covers. This special information must be observed.

Due to the use of PFPE lubricant (LVO 400) and grease, also the maintenance schedule has been changed accordingly.

Only degreased accessories (filters and valves) and original spare parts from Leybold Vacuum must be used.

## Product Selection

SOGEVAC pumps of the following sizes are available:  
SV 16, SV 25, SV 65 B, SV 100 B, SV 200, SV 300 B, SV 630 B (F) and SV 750 B.

The use of PFPE lubricant (LVO 400) will also impair the attainable ultimate pressure depending on the size of the pump.

Local safety regulations (handling of O<sub>2</sub> and PFPE (LVO 400)) must be observed!

## Advantages to the User

- High pumping speed down to ultimate pressure
- Operation of the pump at all pressures between 1000 mbar (750 Torr) and ultimate pressure is possible
- Integrated and effective separation of oil mist
- Compact design
- Air or water cooled
- Environment friendly (low noise and low heat radiation, low vibrations)
- Available in many different variants, motor voltages, ports etc.

## Pump

Pump	Part No.	Ultimate pressure (mbar (Torr))	
		without gas ballast	with gas ballast
SV 16 D	960184V2016, 960185V2016, 960186V2016	1.0 (0.75)	3.0 (2.25)
SV 25 D	960211V2016, 960215V2016	1.0 (0.75)	3.0 (2.25)
SV 65 D	960400V2016, 960401V2016, 960412V2016	1.0 (0.75)	2.5 (1.88)
SV 100 D	960500V2016, 960505V2016, 960512V2016	1.0 (0.75)	2.5 (1.88)
SV 300 B	960702V2016	0.5 (0.375)	1.5 (1.13)

# SOGEVAC SV 40 ATEX (Explosion Protected and Pressure Burst Resistant)



IIA version with MR 40 pressure regulator on the suction side and horizontal suction flanges

The SOGEVAC SV 40 ATEX Cat. 1 rotary vane vacuum pumps comply with the European Directive 2014/34/EU regarding "Equipment and protective systems for use in potentially explosive atmospheres".

### Classification

- Equipment group: II
- Categories: 1G inside  
2G outside
- Zone: 0 inside  
1 outside
- Material group: IIB + H<sub>2</sub> or IIA
- Temperature classes:
 

IIB + H <sub>2</sub>	at 50 Hz, T4
	at 60 Hz, 160 °C
IIA	at 50 and 60 Hz, T3

### Applications

These pumps are suited for pumping solvents, for drying, filling applications including IIB + H<sub>2</sub> or IIA material groups.

### Safety Characteristics

- In order to fulfill the requirements of the safety regulations, the SOGEVAC SV 40 ATEX Cat. 1 pumps are equipped with
- 1 flame arrester on their suction and exhaust sides
  - 1 pressure transmitter controlling the pressure in the oil casing
  - 1 temperature sensor controlling the pump temperature
  - 1 inlet gas temperature monitoring on the inlet side of the pump (for IIB + H<sub>2</sub> versions only).

Furthermore, these pumps have an explosion-proof design.

### Advantages to the User

- High pumping speed down to ultimate pressure
- High vapor pumping capability
- Running possible at any pressure, from 1000 mbar (750 Torr) to ultimate pressure
- Integrated and efficient oil mist separation
- Compact design
- Air cooled
- Environment-friendliness (low noise level, no cooling water, low vibration operation)
- Many different designs available

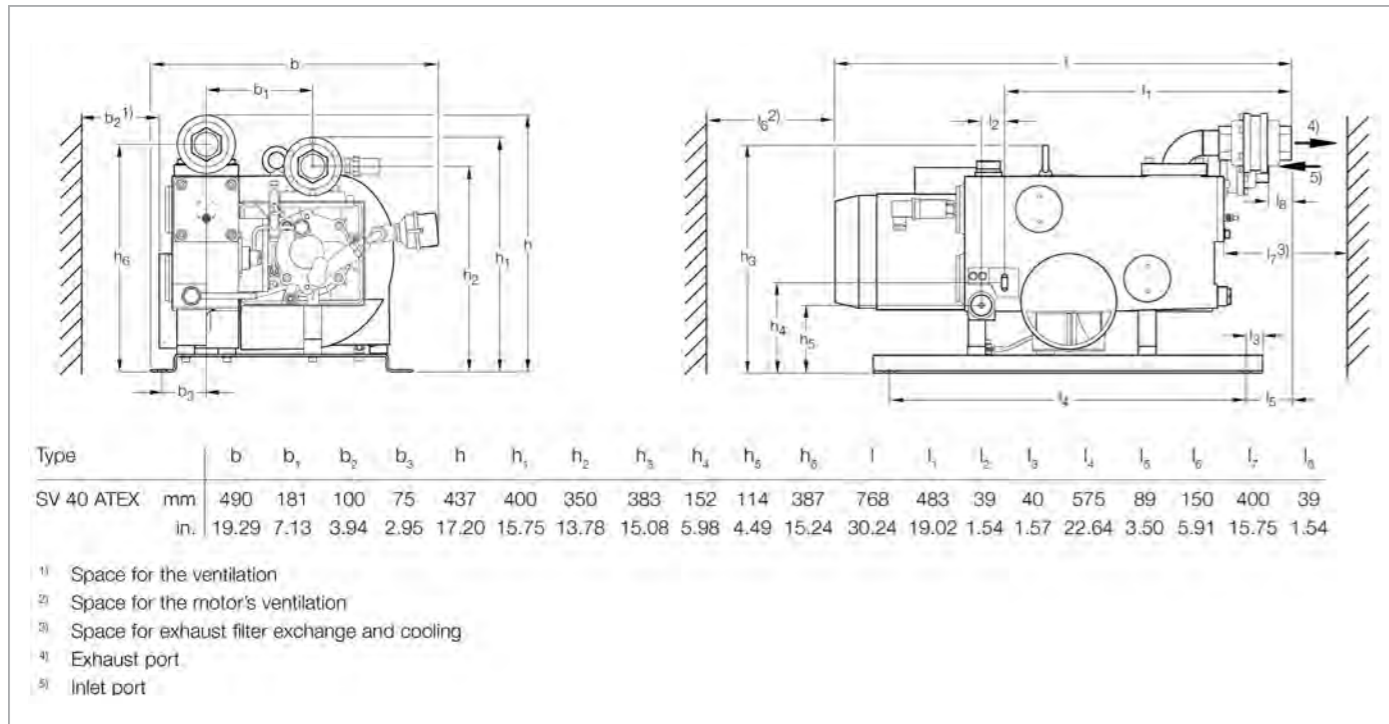

Dimensional drawing for the SOGEVAC SV 40 ATEX with standard motor, European version

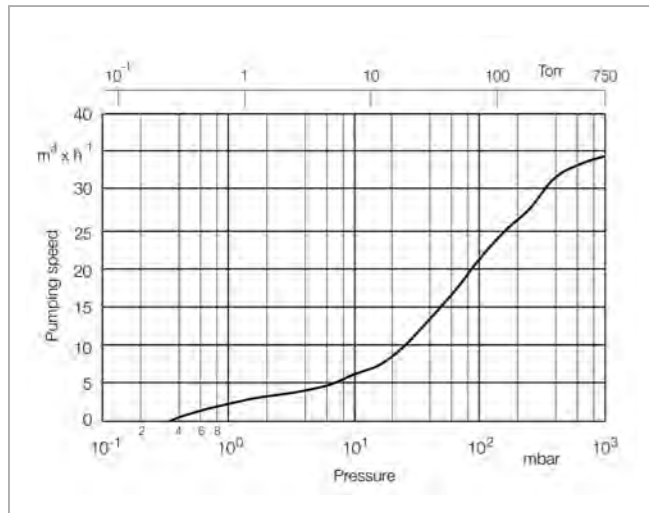

Pumping speed characteristics of the SOGEVAC SV 40 ATEX at 50 Hz for gases of the material group IIB + H<sub>2</sub> (60 Hz curves at the end of the chapter)

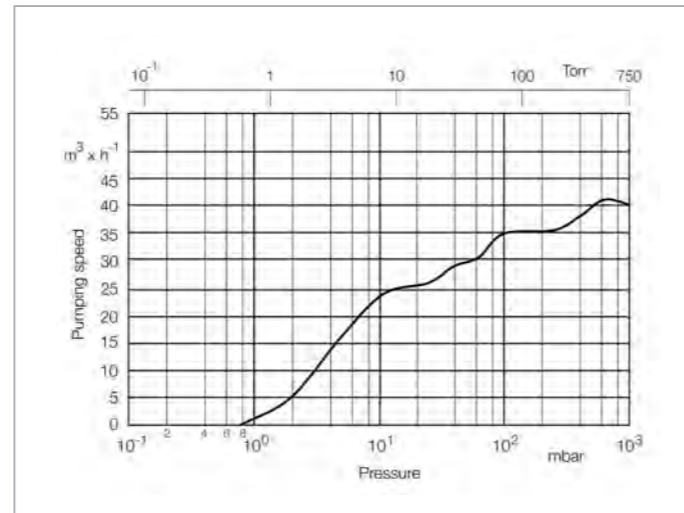

Pumping speed characteristics of the SOGEVAC SV 40 ATEX at 50 Hz for gases of the material group IIA (60 Hz curves at the end of the chapter)







**Technical Data**

**SOGEVAC SV 40 ATEX**

		50 Hz	60 Hz
Nominal pumping speed	m <sup>3</sup> /h (cfm)	46.0 (27.1)	55.2 (32.5)
Pumping speed (according to PNEUROP)			
IIB + H <sub>2</sub>	m <sup>3</sup> /h (cfm)	26 (15.3)	29 (17.1)
IIA	m <sup>3</sup> /h (cfm)	35 (20.6)	42 (24.7)
Ultimate total pressure without gas ballast			
IIA / IIB + H <sub>2</sub>	mbar (Torr)	0.8 (0.6)	
Ultimate total pressure with gas ballast			
II A / IIB + H <sub>2</sub>	mbar (Torr)	1.5 (1.1)	
Noise level (according to DIN 45635)	dB(A)	63	68
Water vapor tolerable load with gas ballast	mbar (Torr)	30 (23)	
Motor power	kW (hp)	1.5 (2.0)	1.8 (2.4)
Rated rotational speed	min <sup>-1</sup> (rpm)	1500 (1500)	1800 (1800)
Standard voltage	V	230/400 (± 10%)	460 (± 10%)
Type of protection	IP	55-F	55-F
Leak rate	mbar x l/s	≤ 1 x 10 <sup>-3</sup>	
Type of oil		LVO 210	
Oil capacity, approx.	l (qt)	2 (2.1)	
Materials (materials in contact with the gas)		Steel, cast iron, Aluminium, Bronze, FPM (FKM), Glass, Polyamid 6.6, Filter material (Polymers, Paper), epoxy resin & glass fibre	
Weight (with oil filling)	kg (lbs)	110 (243)	
Connections			
intake			
IIB + H <sub>2</sub> G	G	1 1/4"	
IIA	G	3/4"	
exhaust	G	1 1/4"	
Maximum gas inlet temperature	°C (°F)	40 (104)	

**Ordering Information**

**SOGEVAC SV 40 ATEX**

	50 Hz	60 Hz
	Part No.	Part No.
SOGEVAC SV 40 ATEX LA IIB + H <sub>2</sub> in accordance with 2014/34/EU [  II 1/2 G Ex h IIB+H2 T4 Ga/Gb (+5°C<Ta<40°C) EC Type Examination Certificate: PTB 04 ATEX 4013 Issue 1 with permanent gas ballast	960 345	-
SOGEVAC SV 40 ATEX LA IIB + H <sub>2</sub> in accordance with 2014/34/EU [  1/2 G Ex h IIB+H2 160C Ga/Gb (+5°C<Ta<40°C) EC Type Examination Certificate: PTB 04 ATEX 4013 Issue 1 without gas ballast	-	960 349 V 3060
SOGEVAC SV 40 ATEX IIB + H2 in accordance with 2014/34/EU [  II 1/2 G Ex h IIB+H2 T4 Ga/Gb (+5°C<Ta<40°C) EC Type Examination Certificate: PTB 04 ATEX 4013 Issue 1 without gas ballast	960 346	-
SOGEVAC SV 40 ATEX IIB + H2 in accordance with 2014/34/EU [  II 1/2 G Ex h IIB+H2 T4 Ga/Gb (+5°C<Ta<40°C) EC Type Examination Certificate: PTB 04 ATEX 4013 Issue 1 with gas ballast and MR40 B pressure regulator	960 343	-
SOGEVAC SV 40 ATEX IIA in accordance with 2014/34/EU [  II 1/2 G Ex h IIA T3 Ga/Gb (+5°C<Ta<40°C) EC Type Examination Certificate: PTB 04 ATEX 4011 Issue 1 without gas ballast	960 344	-
SOGEVAC SV 40 ATEX IIA in accordance with 2014/34/EU [  II 1/2 G Ex h IIA T3 Ga/Gb (+5°C<Ta<40°C) EC Type Examination Certificate: PTB 04 ATEX 4011 Issue 1 with gas ballast and MR40 B pressure regulator	960 342	-
Accessories	upon request	upon request
Spare Parts	upon request	upon request

For all enquiries and orders relating to category 1 and 2 ATEX products please exclusively use our ATEX questionnaire. You can find this questionnaire at the end of the full-line catalog together with the fax forms or on the Internet under "www.leybold.com" under Download Documents in the area Documentation.

# ATEX Category 2 Pumps

**Application**

As soon as gases capable of exploding are being pumped or if such gases are present in the vicinity, then the customer must perform a hazard analysis. In Europe, the ATEX Directives 2014/34/EU need to be observed in this regard. For equipment in Zone 1, ATEX Category 3 SOGEVAC pumps are available.

**Classification**

As in the table below.

**Safety Precautions**

As standard, the pumps are equipped with FPM (FKM) seals, oil filter bypass and oil LEYBONOL LVO 210. Special ATEX exhaust filters, coupling components, motors, floats and final inspections are used, respectively performed. A DN 16 ISO-KF connection for the gas ballast is supplied. All pumps are equipped with Pt100 temperature, oil level and oil casing pressure sensors. The motors are equipped with PTC thermistors.

SOGEVAC pumps of the following sizes are available:  
SV 40 B, SV 65 B, SV 100 B, SV 200, SV 300 B, SV 630 B and SV 750 B

The pumps are supplied with special Operating Instructions (GA), Spare Parts List (ET) and include a CE declaration. This special information must be observed.

LV Restrictions apply for Service and Repairs: please consult us.

Only special accessories (filters, valves, taps) and original spare parts from Leybold must be used.

**Advantages to the User**

- High pumping speed down to ultimate pressure
- Operation of the pump at all pressures between 1000 mbar (750 Torr) and ultimate pressure is possible
- Integrated and effective separation of oil mist
- Compact design
- Air or water cooled
- Different gas ballast variants: without, manual and permanent upon request
- Available in many different variants, motor voltages, ports etc.

**The pumping speed curves for ATEX Category 2 pumps are the same as for non ATEX standard SOGEVAC pumps.**

**Pump**

	Part No.	Ultimate pressure, mbar (Torr)	
		without gas ballast	with gas ballast
SV 40 B air cooled Ex II (i) 2G h IIB + H <sub>2</sub> T3 Gb / (o) 2G IIC T4 Gb (10 °C ≤ T <sub>a</sub> ≤ 40 °C) X	<b>960305A22</b>	0.5 (0.38)	1.5 (1.13)
SV 65 B air cooled Ex II (i) 2G h IIB + H <sub>2</sub> T3 Gb / (o) 2G IIC T4 Gb (10 °C ≤ T <sub>a</sub> ≤ 40 °C) X	<b>960405A22</b>	0.5 (0.38)	1.5 (1.13)
SV 100 B air cooled Ex II (i) 2G h IIB + H <sub>2</sub> T3 Gb / (o) 2G IIC T4 Gb (10 °C ≤ T <sub>a</sub> ≤ 40 °C) X	<b>960505A22</b>	0.5 (0.38)	1.5 (1.13)
SV 120 B air cooled Ex II (i) 2G h IIB + H <sub>2</sub> T3 Gb / (o) 2G IIC T4 Gb (10 °C ≤ T <sub>a</sub> ≤ 40 °C) X	<b>upon request</b>	0.5 (0.38)	1.5 (1.13)
SV 220 B air cooled Ex II (i) 2G h IIB + H <sub>2</sub> T3 Gb / (o) 2G IIC T3 Gb (10 °C ≤ T <sub>a</sub> ≤ 40 °C) X	<b>960602A22</b>	0.15 (1.13)	0.7 (0.53)
SV 300 B air cooled Ex II (i) 2G h IIB + H <sub>2</sub> T3 Gb / (o) 2G IIC T3 Gb (10 °C ≤ T <sub>a</sub> ≤ 40 °C) X	<b>960702A22</b>	0.15 (1.13)	0.7 (0.53)
SV 630 B air cooled Ex II (i) 2G h IIB + H <sub>2</sub> T3 Gb / (o) 3GD IIC T3 Gb (150 °C) (10 ≤ T <sub>a</sub> ≤ 40 °C) X	<b>960863A23</b>	0.15 (1.13)	0.7 (0.53)
SV 630 BF water cooled Ex II (i) 2G h IIB + H <sub>2</sub> T3 Gb / (o) 3GD IIC T3 Gb (150 °C) (10 ≤ T <sub>a</sub> ≤ 40 °C) X	<b>upon request</b>	0.15 (1.13)	0.7 (0.53)
SV 750 B air cooled Ex II (i) 2G h IIB + H <sub>2</sub> T3 Gb / (o) 3GD IIC T3 Gb (150 °C) (10 ≤ T <sub>a</sub> ≤ 40 °C) X	<b>upon request</b>	0.15 (1.13)	0.7 (0.53)
SV 750 BF water cooled Ex II (i) 2G h IIB + H <sub>2</sub> T3 Gb / (o) 3GD IIC T3 Gb (150 °C) (10 ≤ T <sub>a</sub> ≤ 40 °C) X	<b>960877A23</b>	0.15 (1.13)	0.7 (0.53)

ATEX outside Dust: upon request. For SV 630 B(F): as on existing Cat 3 pumps.

SV 630 B(F) and SV 750 B(F) are ATEX Cat 3 only outside.

Gas ballast connection: with DN 16 ISO-KF as on Cat 3 pumps. Manual gas ballast is standard.

SV 40 B to SV 120 B with manual gas ballast are T3 inside. Pumps with permanent gas ballast are T4 inside.

Big gas ballast or no gas ballast available upon request.

**For all enquiries and orders relating to category 1 and 2 ATEX products please exclusively use our ATEX questionnaire.**

**You can find this questionnaire at the end of the full-line catalog together with the fax forms or on the Internet under "www.leybold.com" under Download Documents in the area Documentation.**

# ATEX Category 3 Pumps

## Application

As soon as gases capable of exploding are being pumped or if such gases are present in the vicinity, then the customer must perform a hazard analysis. In Europe, the ATEX Directives 2014/34/EU need to be observed in this regard. For equipment in Zone 2, ATEX Category 3 SOGEVAC pumps are available.

## Classification

As in the table below.

## Safety Precautions

As standard, the pumps are equipped with FPM (FKM) seals, oil filter bypass and oil LEYBONOL LVO 210. Special ATEX exhaust filters, coupling components, motors, floats and final inspections are used, respectively performed. A DN 16 ISO-KF connection for the gas ballast is supplied.

All pumps are equipped with Pt100 temperature, oil level and oil casing pressure sensors. The motors are equipped with PTC thermistors.

SOGEVAC pumps of the following sizes are available:

SV 40 B, SV 65 B, SV 100 B, SV 200, SV 300 B, SV 630 B and SV 750 B

The pumps are supplied with special Operating Instructions (GA), Spare Parts List (ET) and include a CE declaration. This special information must be observed.

Only special accessories (filters, valves, taps) and original spare parts from Leybold must be used.

## Advantages to the User

- High pumping speed down to ultimate pressure
- Continuous operation of the pump at all pressures between 1000 mbar (750 Torr) and ultimate pressure is possible
- Integrated and effective separation of oil mist
- Compact design
- Air or water cooled
- Environment friendly (low noise and low heat radiation, low vibrations)
- Available in many different variants, motor voltages, ports etc.

**Pump**

	Part No.	Ultimate pressure, mbar (Torr)	
		without gas ballast	with gas ballast
SV 40 B air cooled Ex II (i) 3G IIC T3 Gb / (o) 3 GDh IIC T3 Gb (150 °C)(10 ≤ T <sub>a</sub> ≤ 40 °C) X	960305A33	0.5 (0.38)	1.5 (1.13)
SV 65 B air cooled Ex II (i) 3 G IIC T3 Gb / (o) 3 GDh IIC T3 Gb (150 °C)(10 ≤ T <sub>a</sub> ≤ 40 °C) X	960405A33	0.5 (0.38)	1.5 (1.13)
SV 100 B air cooled Ex II (i) 3 G IIC T3 Gb / (o) 3 GDh IIC T3 Gb (150 °C)(10 ≤ T <sub>a</sub> ≤ 40 °C) X	960505A33	0.5 (0.38)	1.5 (1.13)
SV 220 B air cooled Ex II (i) 3 G IIC T3 Gb / (o) 3 GDh IIC T3 Gb (150 °C)(10 ≤ T <sub>a</sub> ≤ 40 °C) X	960602A33	0.15 (1.13)	0.7 (0.53)
SV 300 B air cooled Ex II (i) 3 G IIC T3 Gb / (o) 3 GDh IIC T3 Gb (150 °C)(10 ≤ T <sub>a</sub> ≤ 40 °C) X	960702A33	0.15 (1.13)	0.7 (0.53)
SV 630 air cooled Ex II (i) 3 G IIC T3 / (o) 3 GDh IIC T3 (150 °C)(10 ≤ T <sub>a</sub> ≤ 40 °C) X	960863A33	0.15 (1.13)	0.7 (0.53)
SV 630 BF water cooled Ex II (i) 3 G IIC T3 Gb / (o) 3 GDh IIC T3 Gb (150 °C)(10 ≤ T <sub>a</sub> ≤ 40 °C) X	960867A33	0.15 (1.13)	0.7 (0.53)
SV 750 B air cooled Ex II (i) 3 G IIC T3 Gb / (o) 3 GDh IIC T3 Gb (150 °C)(10 ≤ T <sub>a</sub> ≤ 40 °C) X	upon request	0.15 (1.13)	0.7 (0.53)
SV 750 BF water cooled Ex II (i) 3 G IIC T3 Gb / (o) 3 GDh IIC T3 Gb (150 °C)(10 ≤ T <sub>a</sub> ≤ 40 °C) X	upon request	0.15 (1.13)	0.7 (0.53)

**For all enquiries and orders relating to category 1 and 2 ATEX products please exclusively use our ATEX questionnaire. You can find this questionnaire at the end of the full-line catalog together with the fax forms or on the Internet under "www.leybold.com" under Download Documents in the area Documentation.**

## Dust Filters (Suction Side)



SOGEVAC SV 40 with connected F 40 dust filter and different types of filter cartridges

The filters consist of a steel housing and a lid with three quick locking clips

### Advantages to the User

- Same housing for different cartridges
- High separation capacity
- Quickly exchangeable cartridge

### Paper Filter Cartridge (Standard)

- Separates particles down to 5 µm (Dry process: dust, powders, chips etc.)

### Polyester Filter Cartridge

- Separation of particles down to 5 µm (Moist process: dust, powders, chips etc.)

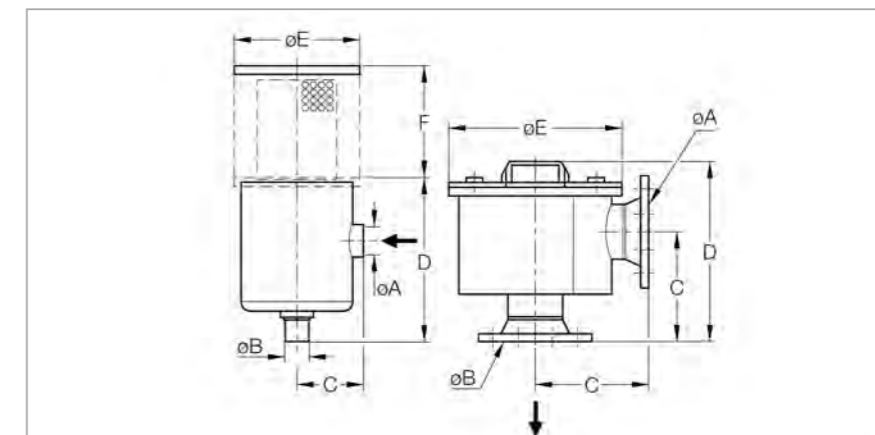

Type		øA	øB	C	D	øE	F	Weight (kg (lbs))
F 16-25	mm	G 1/2"	G 1/2"	54	104	100	70	1
	in.	G 1/2"	G 1/2"	2.13	4.09	3.94	2.76	2.2
F 40	mm	G 1 1/4"	G 1 1/4"	74	115	135	75	1.5
	in.	G 1 1/4"	G 1 1/4"	2.91	4.53	5.31	2.95	3.31
F 65-100	mm	G 1 1/4"	G 1 1/4"	98	172	172	130	2
	in.	G 1 1/4"	G 1 1/4"	3.86	6.77	6.77	5.12	4.4
F 200-300	mm	G 2"	G 2"	118	287	200	230	4.5
	in.	G 2"	G 2"	4.65	11.3	7.87	9.06	9.9
F 200-300	mm	63 ISO-K	63 ISO-K	160	357	258	250	15
	in.	63 ISO-K	63 ISO-K	6.3	14.06	10.16	9.84	33.1
F 630	mm	DN 100 PN 10	DN 100 PN 10	220	358	340	250	33
	in.	DN 100 PN 10	DN 100 PN 10	8.66	14.09	13.39	9.84	72.8
F 630	mm	100 ISO-K	100 ISO-K	220	358	340	250	32
	in.	100 ISO-K	100 ISO-K	8.66	14.09	13.39	9.84	70.6

Dimensional drawing for the dust filters F 16-25 to F 630

### Metal Filter Cartridge

- 0.08 mm (0.003 in.) mesh
- Collects solid particles down to 0.08 mm (0.003 in.) (plastics, paper, packaging materials, foodstuffs)

### Activated Charcoal Cartridge

- Absorbs vapors of high molecular weight (solvent and acid vapors, alkaline solutions etc.)

### Technical Notes

We recommend installing the filters horizontally on a 90° bend. This will prevent separated particles from falling into the intake line when disassembling the filter.

When using an activated charcoal filter it is recommended to also install a paper cartridge filter between the pump and the activated charcoal.

**Technical Data**

**Dust Filter**

Dust Filter	Paper Cartridge	Polyester Filter Cartridge	Metal Cartridge	Active Charcoal Cartridge
Pumping speed reduction through a clean filter	2%	2%	1%	2%
Efficiency for 5 µm particles	98% 99%	98% 99%	- -	- -

**Ordering Information**

**Dust Filter**

	Part No.	Part No.	Part No.	Part No.
Dust Filter	Paper Cartridge	Polyester Filter Cartridge	Metal Cartridge	Active Charcoal Cartridge
F 16-25 for pumps from 10 to 25 m³/h (G 1/2")	951 50	711 27 094	711 27 093	711 27 092
Spare cartridge for F 16-25	710 40 760	712 61 288	E 710 65 813	E 710 65 713
F 40 for SV 40 B (G 1 1/4")	951 55	711 27 104	711 27 103	711 27 102
Spare cartridge for F 40	710 46 118	712 61 298	710 49 083	710 49 103
F 65-100 for SV 65 B, SV 100 B (G 1 1/4")	951 60	711 27 114	711 27 113	711 27 112
Spare cartridge for F 65-100	712 13 283	712 61 308	E 712 13 324	E 712 13 304
F 200-300 for SV 200, SV 300 B (G 2")	951 65	711 27 124	711 27 123	711 27 122
F 200-300 for SV 200, SV 300 B (DN 63 ISO-K)	951 68	711 27 127	711 27 126	711 27 125
Spare cartridge for F 200-300 (G 2" or DN 63 ISO-K)	712 13 293	712 61 318	712 13 334	E 712 13 314
F 630 for SV 630 (B/F), SV 750 (B/F) (DN 100 PN 10)	951 71	711 27 164	711 27 163	711 27 162
F 630 for SV 630 (B/F), SV 750 (B/F) (DN 100 ISO-K)	951 72	711 27 168	711 27 167	711 27 166
Spare cartridge for F 630 (DN 100 PN 10 or DN 100 ISO-K)	710 35 242	712 61 508	E 710 37 734	710 37 724

**Spare Parts**

Set of gaskets for F 16-25	NBR (Buna N)	714 10 820	714 10 820	714 10 820	714 10 820
Set of gaskets for F 40	NBR (Buna N)	714 10 830	714 10 830	714 10 830	714 10 830
Set of gaskets for F 65-100	NBR (Buna N)	714 10 840	714 10 840	714 10 840	714 10 840
Set of gaskets for F 200-300	NBR (Buna N)	714 10 850	714 10 850	714 10 850	714 10 850
O-ring gasket for F 630	NBR (Buna N)	712 41 032	712 41 032	712 41 032	712 41 032

# Only available for purchase in North and South America

## Dust Filters F (Suction Side)



SOGEVAC SV 40 with connected F 40 dust filter and different types of filter cartridges

High efficiency F filters are recommended for use at the inlet of SOGEVAC rotary vane vacuum pumps for protection against process contaminants, e.g., fiberglass particles, plastic dusts, resins and food-processing by-products. The filters are available with easily replaceable cartridge elements for particle filtration of dusts and particulates down to one microns, or activated carbon elements for the adsorption of chemical vapor.

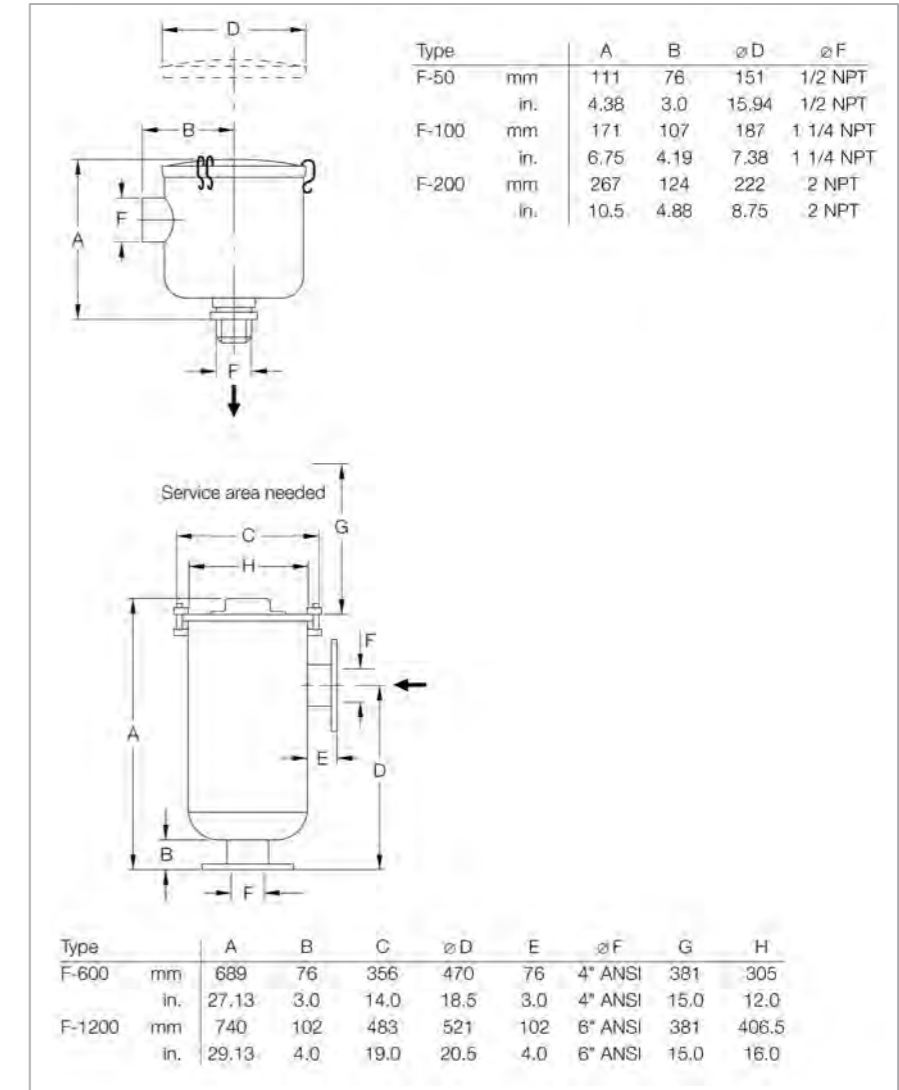

Dimensional drawings for the dust filters F 50 to F 200 (top) and F 600 to F 1200 (bottom)

**Technical Data**

**Dust Filter**

Dust Filter	Polyester Filter Cartridge	Metal Cartridge	Paper Cartridge	Active Charcoal Cartridge
New cartridge pumping speed reduction	2%	1%	2%	2%
Efficiency for 1 µm particulates	98%	-	99%	-
Filter for SV 16 (B), SV 25 (B), UV 25	-	-	F-50	-
Filter for SV 40 (B), SV 65 (B), SV 100 (B)	-	F-100	F-100	F-100
Filter for SV 200, 300 B	-	F-200	F-200	F-200
Filter for SV 500 (B), 630 (B/F)	F-600	-	-	-
Filter for SV 1200	F-1200	-	-	-

**Ordering Information**

**Dust Filter**

Dust Filter	Part No. Polyester Filter Cartridge	Part No. Metal Cartridge	Part No. Paper Cartridge	Part No. Active Charcoal Cartridge
F-50	-	-	<b>899 460</b>	-
Replacement element for F-50	-	-	<b>E 899 461</b>	-
F-100	-	<b>898 527</b>	<b>898 528</b>	<b>898 529</b>
Replacement element for F-100	-	<b>704 44 400</b>	<b>704 13 901</b>	<b>704 13 906</b>
F-200	-	<b>898 530</b>	<b>898 531</b>	<b>898 532</b>
Replacement element for F-200	-	<b>704 45 400</b>	<b>704 14 901</b>	<b>704 14 908</b>
F-600	<b>898 470</b>	-	-	-
Replacement element for F-600	<b>898 471</b>	-	-	-
F-1200	<b>898 475</b>	-	-	-
Replacement element for F-1200	<b>898 476</b>	-	-	-

# LS Separators



SOGEVAC SV 40 with LS 40 separator

The LS 25 separator consists of a collection vessel made of transparent plastic.

Separators LS 40 to LS 750 are welded steel collection vessels acting as liquid traps. These are equipped with connecting threads.

Separators LS 750 are equipped with a cleaning port DN 150 PN 10.

**Advantages to the User**

- Protection of the pumps against liquids which might condense in the intake or the exhaust line when pumping vapors

**Technical Notes**

The separators are equipped with a sight glass tube, so that it is easy to determine when to empty the vessels. The liquid drain is sealed by a screw-in cap. This cap may be replaced by a drain valve.

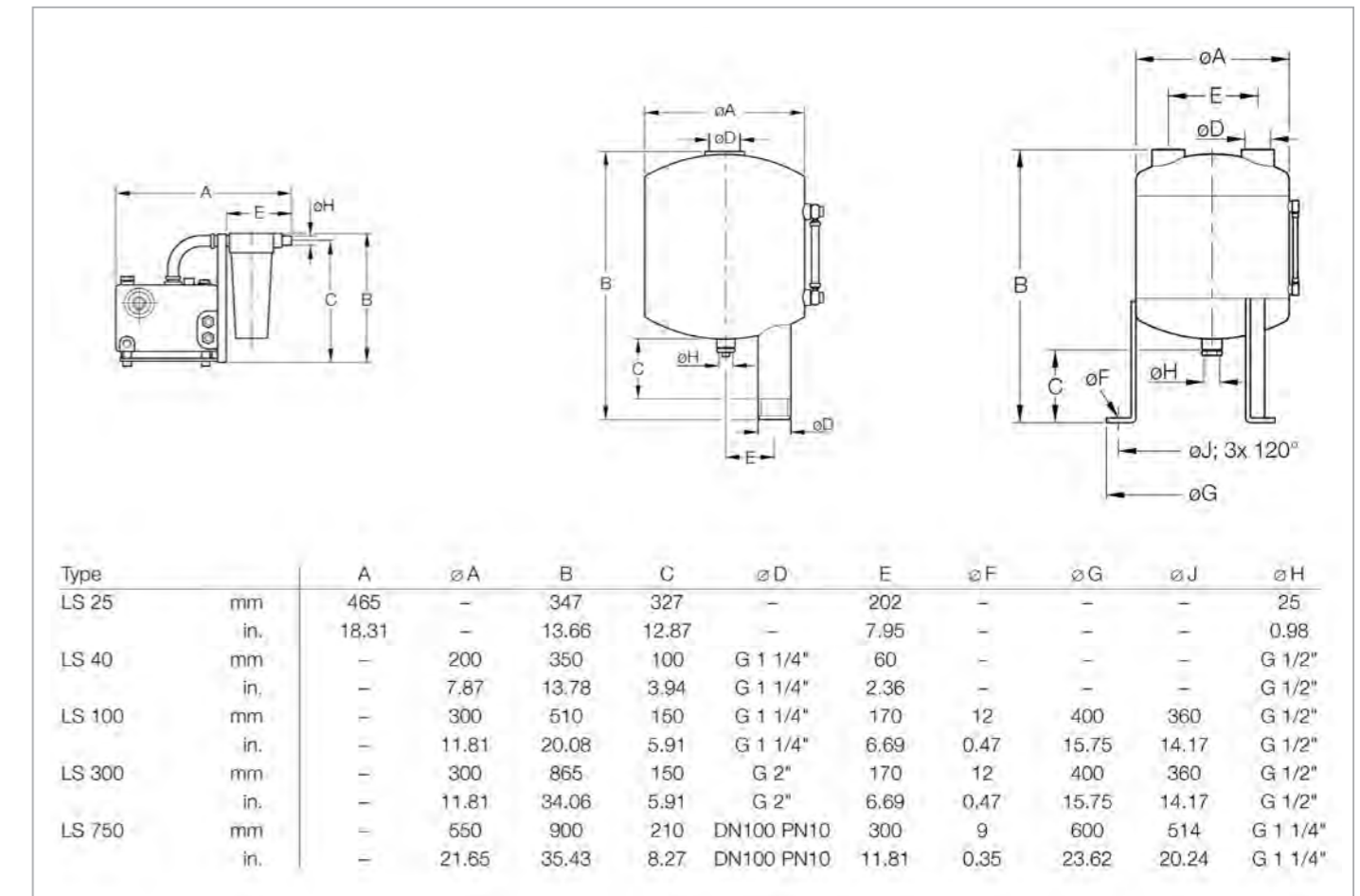

Dimensional drawings for the separators; LS 25 (left), LS 40 (middle) and LS 100 up to LS 750 (right)

**Technical Data**

For pump	SOGEVAC	Separator		
		LS 25	LS 40	LS 100
		for Pumps from 10 to 25 m <sup>3</sup> /h	SV 40 B	SV 40 B/65 B/100 B
Condensate capacity	l (qt)	2.0 (2.1)	4.0 (4.2)	16.0 (16.9)
Weight	kg (lbs)	3.5 (7.7)	5.0 (11.0)	11.0 (24.3)

**Ordering Information**

	Separator		
	LS 25	LS 40	LS 100
	Part No.	Part No.	Part No.
Liquid trap	951 38	951 40	951 42
Liquid trap with electrical level switch	-	-	951 429 901
Drain valve	-	711 30 111	711 30 113

**Technical Data**

For pump	SOGEVAC	Separator	
		LS 300	LS 750
		SV 200/300 B	SV 500/630/750 (B)(F)
Condensate capacity	l (qt)	40.0 (42.3)	80.0 (84.6)
Weight	kg (lbs)	17.0 (37.5)	58.0 (127.9)

**Ordering Information**

	Separator	
	LS 300	LS 750
	Part No.	Part No.
Liquid trap	951 44	951 47
Liquid trap with electrical level switch	951 449 900 001	-
Drain valve		711 30 105
Double spigot for drain valve	-	711 18 033

Only available for purchase in North and South America

**Ordering Information**

	Separator		
	LS 25	LS 40	LS 100
	Part No.	Part No.	Part No.
Liquid trap	951 38 (BSP)	951 40 (NPT)	951 43 (NPT)
Liquid trap with electrical level switch	-	-	951 429 901
Drain valve	-	711 30 111	711 30 113

**Ordering Information**

	Separator	
	LS 300	LS 750
	Part No.	Part No.
Liquid trap	951 45 (NPT)	951 47 (BSP)
Liquid trap with electrical level switch	951 449 900 001	-
Drain valve		711 30 105
Double spigot for drain valve	-	711 18 033

## Gas Ballast Valve

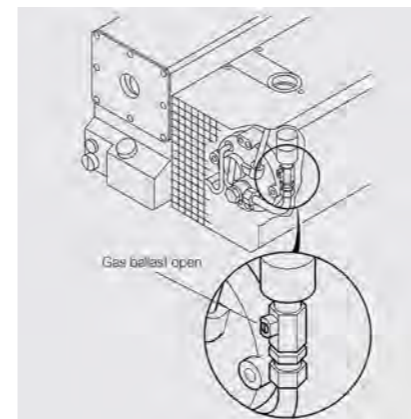

The pumps SOGEVAC SV 10 B, SV 16 B and SV 25 B are equipped depending of their Part No. without or with a permanent gas ballast.

The pumps SOGEVAC SV 16, SV 25, SV 40 B, SV 65 B, SV 100 B, SV 500 B(F), SV 630 B(F) and SV 750 B(F) are equipped depending of their Part No. without or with a manual, permanent or solenoid gas ballast.

The gas ballast valve may also easily be retrofitted to the SV 40, SV 65, SV 100, SV 200 and SV 300 (either standard, large or solenoid).

**Technical Notes**

The gas ballast valve permits pumping of condensable vapors.

The permissible quantities of water are stated in the technical data section.

## Thermal Switch

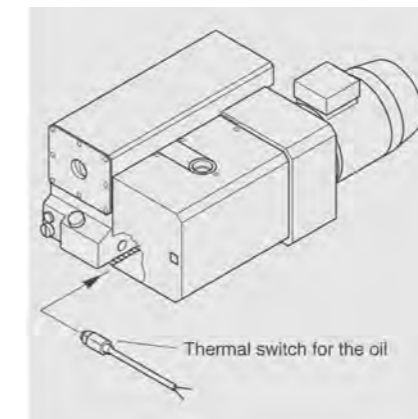

The thermal switch is installed at the hottest point of the pump module. It responds as soon as the temperature of the pump exceeds the maximum operating temperature. This accessory is recommended when operating the pump at high ambient temperatures.

Ratings for the normally closed contact:  
25 V AC, 50 Hz – 5 A  
60 V DC – 3 A

The SV 500, SV 630 and SV 750 B(F) include this switch as a standard.

### Ordering Information

### Accessories

		Part No.	Part No.	Part No.	Part No.
For pump	SOGEVAC	SV 16 (B)/25	SV 25 B	SV 28 BI	SV 40 B
Gas ballast valve (standard)		integrated	integrated	<b>971 462 640</b>	<sup>2)</sup>
Thermal switch		-	<sup>2)</sup>	<b>upon request</b>	<sup>3)</sup>
Oil level monitor		<b>711 19 108</b>	<sup>2)</sup>	-	<b>711 19 110</b>
Gas ballast big		-	<sup>5)</sup>	-	<sup>4)</sup>
Gas ballast, electromagnetic with 24 V DC valve		-	-	<b>upon request</b>	<b>upon request</b>
Exhaust filter monitoring switch		-	-	-	<b>971 425 890</b>

### Ordering Information

### Accessories

		Part No.	Part No.	Part No.	Part No.
For pump	SOGEVAC	SV 40 B	SV 65 B	SV 100/120 B	SV 220 B <sup>3), 8)</sup>
Spare cartridge for F 16-25		<sup>1)</sup>	<sup>1)</sup>	<sup>1)</sup>	<b>GK6703134</b>
Thermal switch		<sup>3)</sup>	<sup>3)</sup>	<sup>3)</sup>	<b>971463930</b>
Oil level monitor		<b>711 19 110</b>	<b>711 19 110</b>	<b>711 19 110</b>	<b>71221992V</b>
Gas ballast big		-	<sup>6)</sup>	<sup>7)</sup>	<b>9600GBB</b>
Gas ballast, electromagnetic with 24 V DC valve		<b>upon request</b>	<b>upon request</b>	<b>upon request</b>	<b>GK6704190</b>
Exhaust filter monitoring switch		<b>971 425 890</b>	<b>971 425 890</b>	<b>971 425 890</b>	<b>971471210</b>

### Ordering Information

### Accessories

		Part No.	Part No.
For pump	SOGEVAC	SV 300 B	SV 630 B(F), SV 750 B(F) <sup>3), 8)</sup>
Gas ballast valve (standard)		<b>971 464 130</b> <sup>9)</sup>	integrated (24 V DC)
Thermal switch		<b>971 463 930</b>	integrated
Oil level monitor		<b>upon request</b>	<b>971 425 760</b>
Gas ballast kit		<b>971 464 130</b> <sup>9)</sup>	-
Gas ballast, electromagnetic with 24 V DC valve		<b>upon request</b>	<b>971 438 170</b>
Exhaust filter monitoring switch		<b>upon request</b>	<b>712 22 360</b>

- <sup>1)</sup> According to variant
- <sup>2)</sup> Can not be retrofitted
- <sup>3)</sup> Please state when ordering the pump
- <sup>4)</sup> See pump with Part No. 960 305 V 2040
- <sup>5)</sup> See pump with Part No. 960 251 V 2040
- <sup>6)</sup> See pump with Part No. 960 405 V 0040
- <sup>7)</sup> See pump with Part No. 960 505 V 2040
- <sup>8)</sup> Second gas ballast possible. Contact Leybold
- <sup>9)</sup> SV 300 B gas ballast kit (Part No. 971 464 130) includes all parts for small, standard and big gas flow

## Mobile Base Frame



Mobile base frame

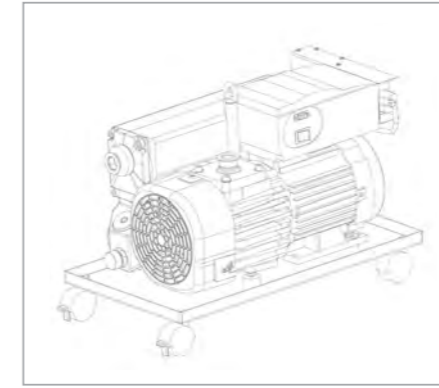

SOGEVAC pump upon mobile base frame

The mobile base frame allows moving easily single and double stage rotary vane pumps up to 65 m<sup>3</sup>/h and facilitates therefore their maintenance.

The oil tight base frame allows to hold up to 2 l (2,1 qt) oil and has swivable casters of which 2 have breaks.

The base frame doesn't alter the pump noise and facilitates oil draining and pump displacement.

Oil Sealed Vacuum Pumps

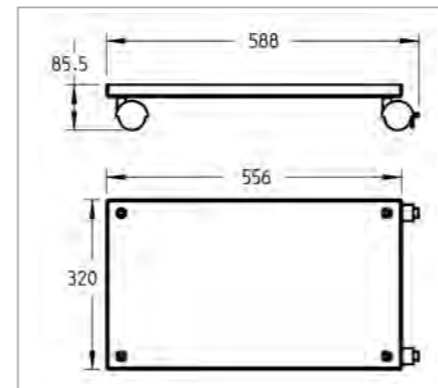

Dimensional drawing for the mobile base frame

### Technical Data

### Mobile Base Frame

Net weight, approx..	kg (lbs)	3 (7)
Max. load	kg (lbs)	90 (200)
Oil recovery volume, max.	l (qt)	2 (2.1)
Caster diameter	mm (in)	50 (2)
Material oil pan		Stainless steel

### Ordering Information

### Mobile Base Frame

		Part No.
For pump	SOGEVAC	Single and double stage pumps up to 65 m <sup>3</sup> /h
Mobile base frame		<b>960 331 BASE</b>
Mobile base frame for pumps bigger than 65 m <sup>3</sup> /h until 120 m <sup>3</sup> /h		<b>960560WB</b>

# Noise Enclosure

Leybold has developed a specific noise enclosure for vacuum pumps, which reduce the noise level by approx. 5 dB(A) and which makes sure the pump doesn't overheat due to the open design on both sides.

A combination with the mobile base frame is possible.

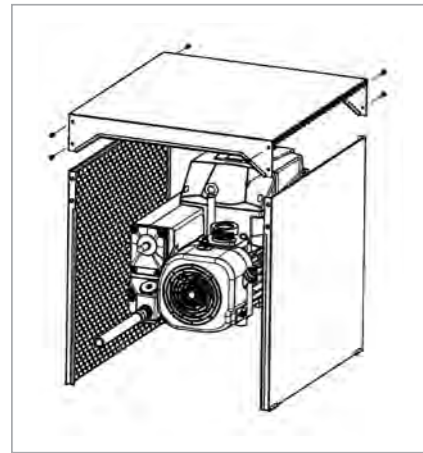

Noise enclosure

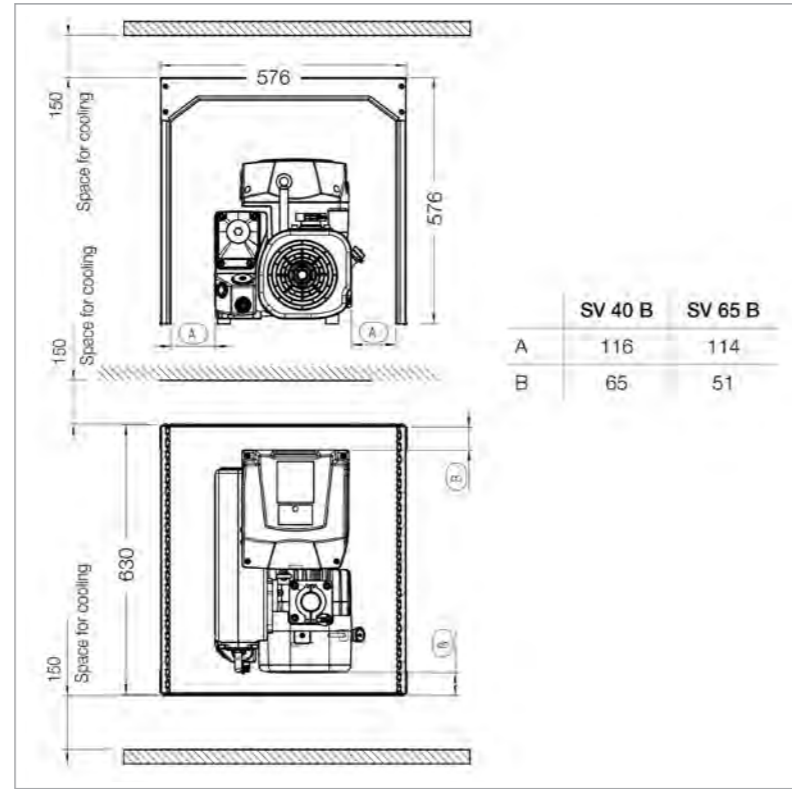

Dimensional drawing for the noise enclosure, dimensions in mm

## Technical Data

		kg (lbs)	12.2 (27)
Net weight, approx.			
Noise reduction, approx..	dB(A)		5
Temperature increase below top, max.	°C (°F)		7 (45)
Ambient temperature , max.	°C (°F)		34 (93)
Material frame absorption foam material		Galvanised steel acc. UL-94 HF1	

## Noise Enclosure

## Ordering Information

		Part No.	Part No.
For pump	SOGEVAC	Single stage rotary vane pumps up to 65 m <sup>3</sup> /h and double stage rotary vane pumps up to 25 m <sup>3</sup> /h	Single stage rotary vane pumps up to 120 m <sup>3</sup> /h and double stage rotary vane pumps up to 65 m <sup>3</sup> /h
Noise enclosure		960 331 NENC	960 560 NENC

# Mounting Accessories

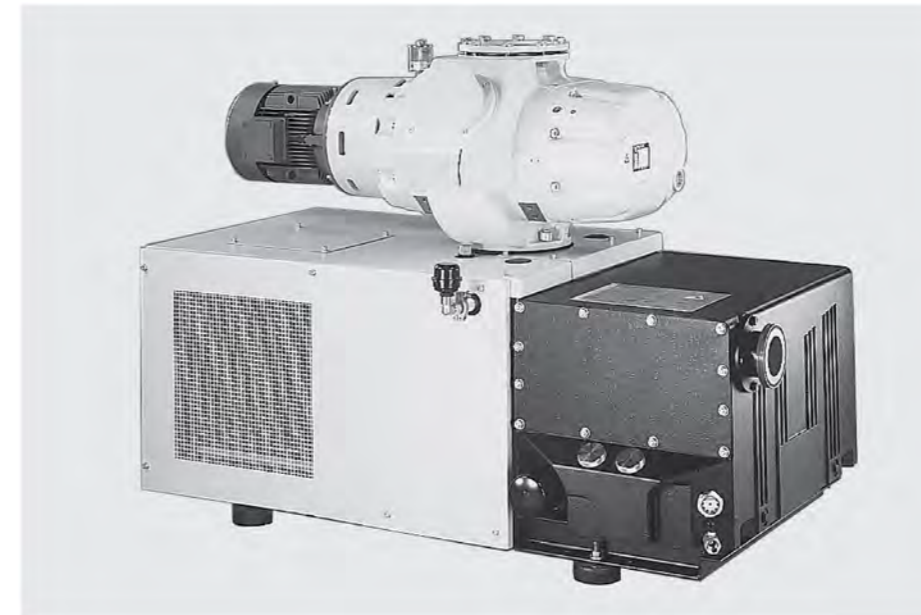

SOGEVAC SV 630 F with RUVAC WAU 2001



SOGEVAC SV 200 with RUVAC WAU 501

## Ordering Information

		Part No.	Part No.	Part No.	Part No.	Part No.
For pump	SOGEVAC	SV 16 BI	SV 25 B	SV 28 BI	SV 40 B	SV 40 BI
Oil drain valve G 3/4"			711 30 114	711 30 114	711 30 114	711 30 114
Base frame for Roots installation						not possible

## Mounting Accessories

## Ordering Information

		Part No.	Part No.	Part No.	Part No.
For pump	SOGEVAC	SV 40/65 B	SV 100 B	SV 220 B	SV 40 B
Base frame		971 453 840	971 434 000	711 19 208	711 19 208
Oil drain valve G 3/4"		711 30 114	711 30 114	711 30 114	711 30 114
Base frame for Roots installation		not possible	971 448 830 <sup>1)</sup>	711 19 209 <sup>2)</sup>	971 456 590

<sup>1)</sup> Mandatory for direct Roots mounting

<sup>2)</sup> Required for mounting the WAU 1001 on to the SV 200

# Exhaust Filter Gauge

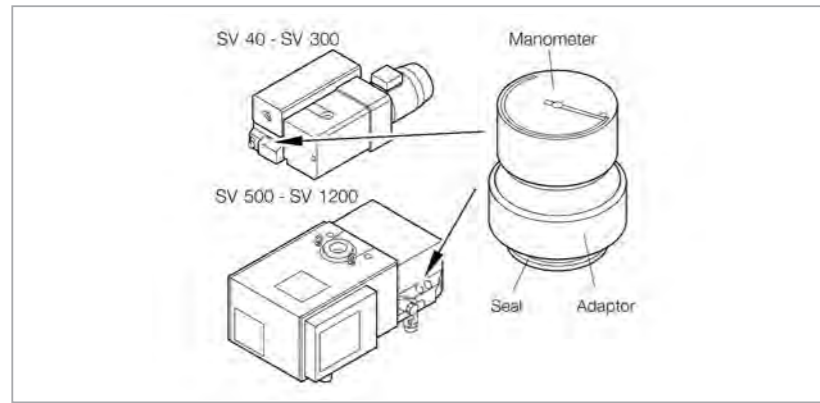

The manometer (40 mm (1.58 in.) dia.), glued in the adapter, is installed instead of the oil filling plug. Dial has 2 colors:

green:  $1000 < p < 1450$  mbar abs.  
( $760 < p < 1090$  Torr abs.)  
Exhaust filter OK

red:  $p > 1450$  mbar abs.  
( $> 1090$  Torr abs.)  
Exhaust filter clogged

## Technical Notes

The reliability of the manometer applies only provided the pump has

attained its operating temperature and when the intake pressure is high.

## Ordering Information

		Exhaust Filter Gauge	
		Part No.	Part No.
For pump	SOGEVAC	SV 10 B to SV 25 B, SV 28 BI	SV 40 B(I) to SV 750 B(F)
Manometer (with adaptor and seal)		951 93	951 94

<sup>1)</sup> Not visible from outside

# Single Phase Power Supply Cables

## Ordering Information

Part No.	Plug pump side	Plug supply side	Length in m
971457EUR	Hirschmann	Euro / Schuko 16 A	2.5
971457GB	Hirschmann	UK plug 13 A	2.5
971457NEMA	Hirschmann	NEMA 6-15P 250 V	2.5
971457CH	Hirschmann	CH plug 10 A	2.5
971457WW	Hirschmann	w/o	2.5
EK6506966	Hirschmann	IEC 309 16 A	5
EK6510715	Hirschmann	C20	2.5
EK6510720	C19	C14	2.5
141103US	C19	NEMA 5-15P 125 V	1.8
161810US	C19	NEMA 6-15P 250 V	1.8
161810EU	C19	Euro / Schuko 16 A	1.8
161810UK	C19	UK plug 13 A	1.8
161810CN	C19	China Australia type I	1.8
E6500825	C19	C20	2.5
E6505883	C13	IEC 309 16 A	5
EK6502798	C13	C14	2.5
971443450	C13	Euro / Schuko 16 A	2
EK6508756	C13	NEMA 6-15P 250 V	2
6534485V	C13	NEMA 5-15P 125 V	
9714434GB	C13	UK plug 13 A	2
9714434CH	C13	CH plug 10 A	2
9714434WW	C13	w/o	2
E6500255	C13	C14	2.5
EK6701862	C13	C20	0.2

## Ball Valves and Valves



Ball valve 1 1/4"

### Advantages to the User

- Leak rate  $< 1 \times 10^{-6}$  mbar x l/s ( $\leq 0.75 \times 10^{-6}$  Torr x l x s<sup>-1</sup>)
- Seals on both sides against the atmosphere
- Opens against atmospheric pressure
- Small size
- Simple and quick to operate
- Pressure range from  $10^{-2}$  to 1000 mbar ( $0.75 \times 10^{-2}$  to 750 Torr)
- Smaller models serve as venting valves

Information on the blocking components is provided in the Catalog Part "Vacuum Valves".

### Material

The housing of the ball valves is made of brass, the ball of hard-chrome plated brass, the valve seat of PTFE.

The housing of the right angle valve is made of aluminium, the spindle and valve plate are sealed with an O-ring and are made of stainless steel.

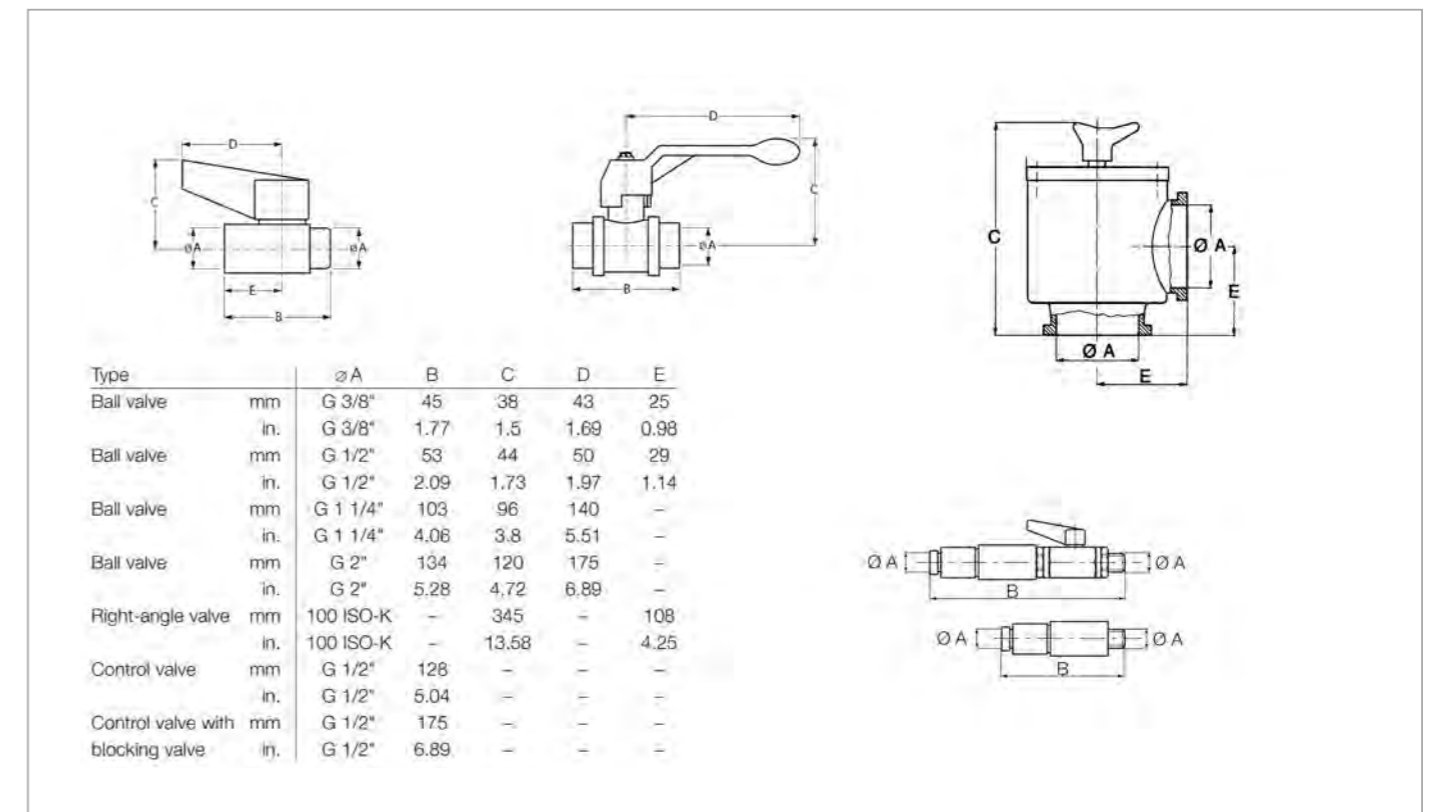

Dimensional drawings for the ball valves; G 3/8" and G 1/2" (left), G 1 1/4" and G 2" (middle), right-angle valves (right) and for the control valves (bottom)

**Technical Data**

**Ball Valves and Valves <sup>1)</sup>**

Type	Ball valve	Ball valve	Ball valve	Ball valve	
Connection	F/M 3/8" BSP	F/M 1/2" BSP	F/F 1 1/4" BSP	F/F 2" BSP	
Weight	kg (lbs)	0.12 (0.3)	0.15 (0.33)	1.24 (2.7)	3.22 (7.1)

**Ordering Information**

**Ball Valves and Valves <sup>1)</sup>**

Type	Ball valve	Ball valve	Ball valve	Ball valve
	971 471 220	711 30 113	711 30 100	711 30 107

<sup>1)</sup> Special versions for oxygen applications are available upon request

Only available for purchase in North and South America

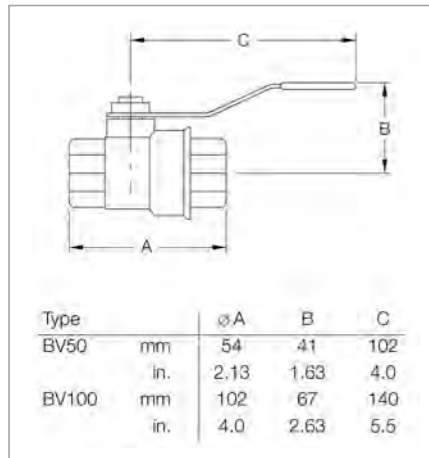

**Technical Data**

**Ball Valves**

Type	Ball valve	Ball valve
Connection	1/2-inch NPT(F)	1 1/4-inch NPT(F)

**Ordering Information**

**Ball Valves**

Type	Ball valve	Ball valve
	899 810	899 800

Dimensional drawing for the ball valves BV

# Bourdon Vacuum Gauges / DIAVAC DV 1000



Oil Sealed Vacuum Pumps

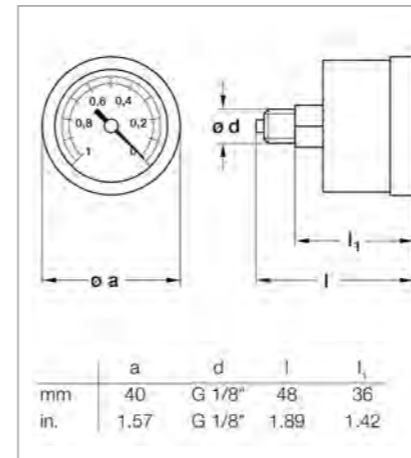

Dimensional drawing for the Bourdon vacuum gauge Part No. 951 90

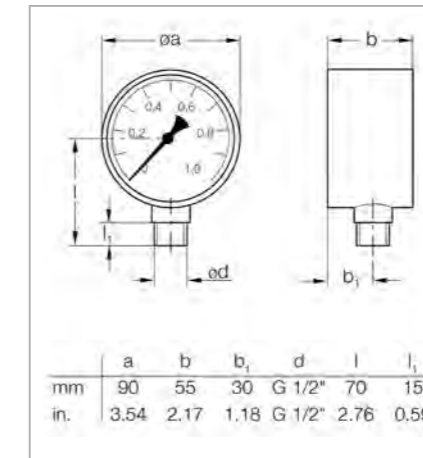

Dimensional drawing for the Bourdon vacuum gauge Part No. 951 92

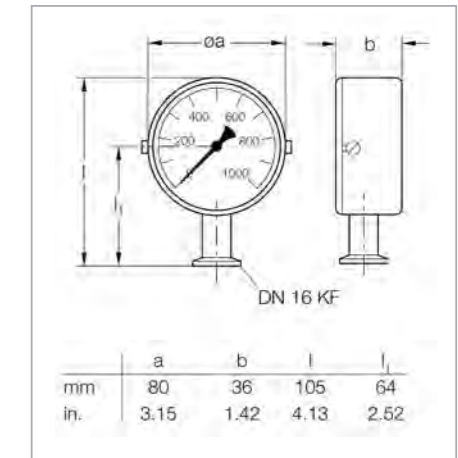

Dimensional drawing for the Bourdon vacuum gauge Part No. 160 40



DIAVAC DV 1000

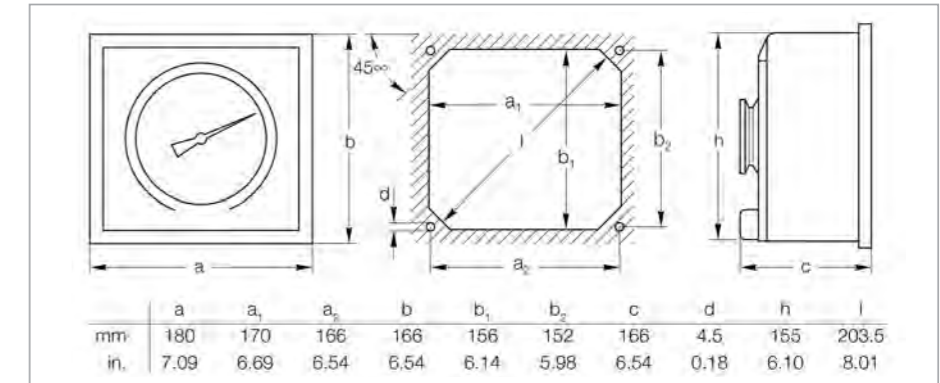

Dimensional drawing and panel cut-out for the DIAVAC DV 1000, Part No. 160 67

### Advantages to the User

- Simple, rugged and vibration insensitive vacuum gauges for the rough vacuum range
- Linear response
- Clear dial which can also be read from a great distance
- Readings independent of atmospheric pressure

### Technical Data

#### Bourdon Vacuum Gauges / DIAVAC DV 1000

Measuring range	0 to 100%	0 to 1 bar	0 to 1020 mbar	1 to 1000 mbar	
Vacuum connection	M 1/8" BSP	M 1/2" BSP	DN 16 ISO-KF	DN 40 ISO-KF	
Scale length	mm (in.)	55 (2.17)	140 (5.51)	140 (5.51)	270 (10.63)
Overall height	mm (in.)	48 (1.89)	115 (4.53)	105 (4.13)	166 (6.54)
Weight	g (lbs)	60 (0.13)	560 (1.24)	300 (0.66)	2700 (5.96)
Indication		low pressure in bar	absolute pressure in mbar	absolute pressure in mbar	absolute pressure in mbar

### Ordering Information

#### Bourdon Vacuum Gauges / DIAVAC DV 1000

	Part No.	Part No.	Part No.	Part No.
Bourdon Vacuum Gauges	951 90	951 92	160 40	-
DIAVAC DV 1000	-	-	-	711 30 107

Standard vacuum gauge for all SOGEVAC pumps is Part No. 951 92.  
Further information on other vacuum gauges is provided in Catalog Part "Vacuum Measuring, Controlling"

## Only available for purchase in North and South America

## Other Accessories

### External Carbon Exhaust Filters

An external type spin-on filter made of activated carbon on a polyester cloth housed in wire mesh. Used for providing additional protection from oil odor or mist expelled from pump exhaust. Requires NPT type nipple and street elbow for preferred vertical mounting. SV 16/25 requires nipple only.

#### Technical Data

#### External Carbon Exhaust Filters

Model	SVXCXF 50	SVXCXF 100	SVXCXF 200
Fits pump	SOGEVAC SV 16 / 25 (B)	SV 40 B / 65 B / SV 100 B	SV 200/300
Thread size	1/2" NPT-M	1 1/4" NPT-M	2" NPT-M

#### Ordering Information

#### External Carbon Exhaust Filters

	Part No.	Part No.	Part No.
Model	SVXCXF 50	SVXCXF 100	SVXCXF 200
External carbon exhaust filters	899 502	899 500	899 498
Replacement element	899 503	899 501	899 499

## Connection Fittings for SOGEVAC SV 10 B, SV 16, SV 16 B, SV 16 D, SV 25, SV 25 B, SV 25 D

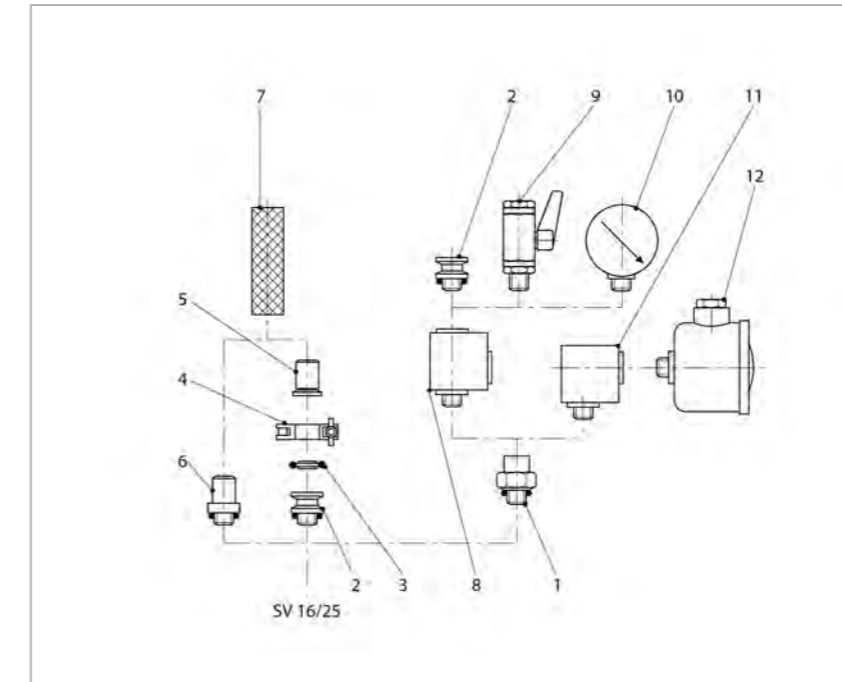

Connection fittings for SOGEVAC SV 10 B, SV 16 B, SV 25 B and SV 16, SV 25

The fittings presented have been specially matched to the SOGEVAC pumps. We recommend to use only these or other components from Leybold for connecting SOGEVAC pumps, so as not to impair the pumping speed of the pumps or the leak tightness of the system.

More information on further fittings is provided in Catalog Part "Flanges and Fittings".

### Technical Data

### Connection Fittings

Item	Description	Connection	Material
1	Screw coupling	G 1/2" M/F	Aluminium
2	Threaded flange adaptor <sup>1)</sup>	G 1/2" M – DN 16 ISO-KF	Aluminium, anodized
3	Centering ring <sup>1)</sup>	DN 16 ISO-KF	Aluminium
4	Clamping ring	DN 10/16 ISO-KF	Aluminium
5	Hose connection	DN 16 ISO-KF – DN 25 mm (0.39 in.)	Aluminium, anodized
6	Hose connection <sup>1)</sup>	G 1/2" M – DN 25 mm (0.39 in.)	Aluminium, anodized
7	PVC tubing	5 mm (0.39 in.) dia., 1 m (3.5 ft) long	PVC
8	Tee piece	G 1/2" M/F/F	Aluminium, anodized
9	Ball valve	G 1/2" M/F	Brass, nickered
10	Bourdon vacuum gauge	G 1/2" M	
11	Elbow 90°	G 1/2" M/F	Aluminium, anodized
12	Dust filter	G 1/2" M/F	
13	Inlet reduction <sup>1)</sup> (not shown)	G 1/2" F – G 3/4" M	galvanised steel

<sup>1)</sup> With NBR-O-Ring

M = Outside thread  
F = Inside thread

## Ordering Information

Item	Description	SV 10 B	Connection Fittings SV 16, 16 B, 16 D	SV 25, 25 B, 25 D
		Part No.	Part No.	Part No.
1	Screw coupling	711 18 020	711 18 020	711 18 020
2	Threaded flange adaptor <sup>1)</sup>	711 18 120	711 18 120	711 18 120
3	Centering ring <sup>1)</sup>	183 26	183 26	183 26
4	Clamping ring	183 41	183 41	183 41
5	Hose connection	711 18 300	711 18 300	711 18 300
6	Hose connection <sup>1)</sup>	711 18 011	711 18 011	711 18 011
7	PVC tubing	711 18 323	711 18 323	711 18 323
8	Tee piece	711 18 250	711 18 250	711 18 250
9	Ball valve	711 30 113	711 30 113	711 30 113
10	Bourdon vacuum gauge	951 92	951 92	951 92
11	Elbow 90°	711 18 210	711 18 210	711 18 210
12	Dust filter <sup>2)</sup>			
	with paper cartridge	951 50	951 50	951 50
	with activated charcoal cartridge	711 27 092	711 27 092	711 27 092
	with metal cartridge	711 27 093	711 27 093	711 27 093
	with polyester filter cartridge	711 27 094	711 27 094	711 27 094
13	Inlet reduction <sup>1)</sup> (not shown)	951 24	951 24	951 24

## Special versions for oxygen applications are available upon request

<sup>1)</sup> With NBR-O-Ring

<sup>2)</sup> See "Dust Filters F (Suction Side)" for other options

# Connection Fittings for SOGEVAC SV 40 B, SV 65 B, SV 100 B

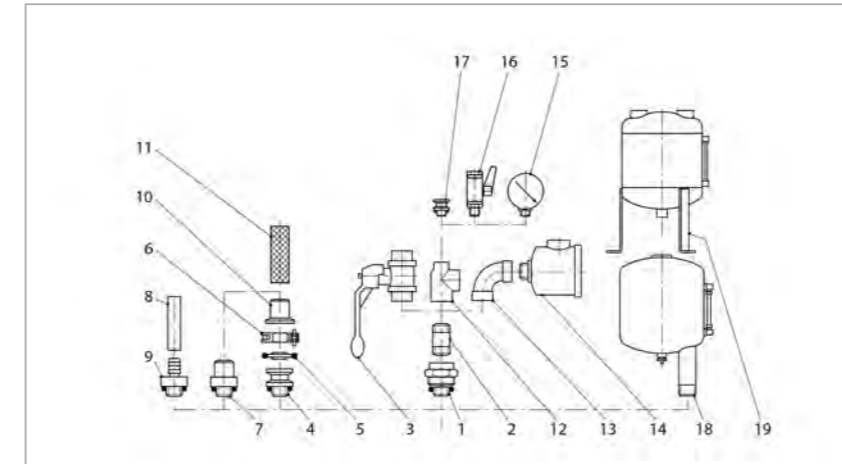

Connection fittings for SOGEVAC SV 40 B, SV 65 B, SV 100 B

## Technical Data

## Connection Fittings

Item	Description	Connection	Material
1	Screw coupling	G 1 1/4" M/F	Aluminium, NBR
2	Double nipple	G 1 1/4" M/M	Steel
3	Ball valve	G 1 1/4" F/F	Brass, nickered
4	Threaded flange adaptor <sup>1)</sup>	G 1 1/4" M – DN 40 ISO-KF	Aluminium, anodized
5	Centering ring	DN 40 ISO-KF	Aluminium
6	Clamping ring	DN 32/40 ISO-KF	Aluminium
7	Hose connection <sup>1)</sup>	G 1 1/4" M / DN 40 mm (1.58 in.)	Aluminium, anodized
8	Rubber hose	dia 10 x 25 mm (0.39 x 0.98 in.), 1 m (3.5 ft) long	
9	Hose connection <sup>1)</sup>	G 1 1/4" M – DN 10	Aluminium, anodized
10	Hose connection	DN 40 ISO-KF/DN 40 mm	Aluminium, anodized
11	PVC tubing	DN 40 ISO-KF/DN 40 mm (1.58 in.)	
12	Tee reducer bush	G 1 1/4" – 1 1/4" – 1/2" F/F/F	Gray cast iron
13	Elbow 90°	G 1 1/4" F/F	Gray cast iron
14	Dust filter	G 1 1/4" M/F	
15	Bourdon vacuum gauge	G 1/2" M	
16	Ball valve	G 1/2" M/F	Brass, nickered
17	Threaded flange adaptor <sup>1)</sup>	G 1/2" M – DN 16 ISO-KF	Aluminium, anodized
18	Liquid trap	G 1 1/4" – 1 1/4" – 3/8" M/F	
19	Liquid trap	G 1 1/4" – 1 1/4" – 1/2" F/F/F	

<sup>1)</sup> inkl. O-Ring

M = Outside thread  
F = Inside thread

## Ordering Information

Item	Description	SV 40 B	Connection Fittings SV 65 B	SV 100 B
		Part No.	Part No.	Part No.
1	Screw coupling	711 18 023	711 18 023	711 18 023
2	Double nipple	711 18 033	711 18 033	711 18 033
3	Ball valve	711 30 105	711 30 105	711 30 105
4	Threaded flange adaptor <sup>1)</sup>	711 18 123	711 18 123	711 18 123
5	Centering ring <sup>1)</sup>	183 28	183 28	183 28
6	Clamping ring	183 43	183 43	183 43
7	Hose connection <sup>1)</sup>	711 18 013	711 18 013	711 18 013
8	Rubber hose	172 03	172 03	172 03
9	Hose connection <sup>1)</sup>	711 18 153	711 18 153	711 18 153
10	Hose connection	711 18 303	711 18 303	711 18 303
11	PVC tubing	711 18 324	711 18 324	711 18 324
12	Tee reducer bush	711 18 263	711 18 263	711 18 263
13	Elbow 90°	711 18 213	711 18 213	711 18 213
14	Dust filter with paper cartridge with activated charcoal cartridge with metal cartridge with polyester filter cartridge	951 55 711 27 102 711 27 103 711 27 104	951 60 711 27 112 711 27 113 711 27 114	951 60 711 27 112 711 27 113 711 27 114
15	Bourdon vacuum gauge	951 92	951 92	951 92
16	Ball valve	711 30 113	711 30 113	711 30 113
17	Threaded flange adaptor <sup>1)</sup>	711 18 120	711 18 120	711 18 120
18	Liquid trap	951 40	-	-
19	Liquid trap	951 42	951 42	951 42

Special versions for oxygen applications are available upon request

<sup>1)</sup> With NBR-O-Ring

<sup>2)</sup> See "Dust Filters F (Suction Side)" for other options

## Connection Fittings for SOGEVAC SV 220 B, SV 300 B, SV 320 B

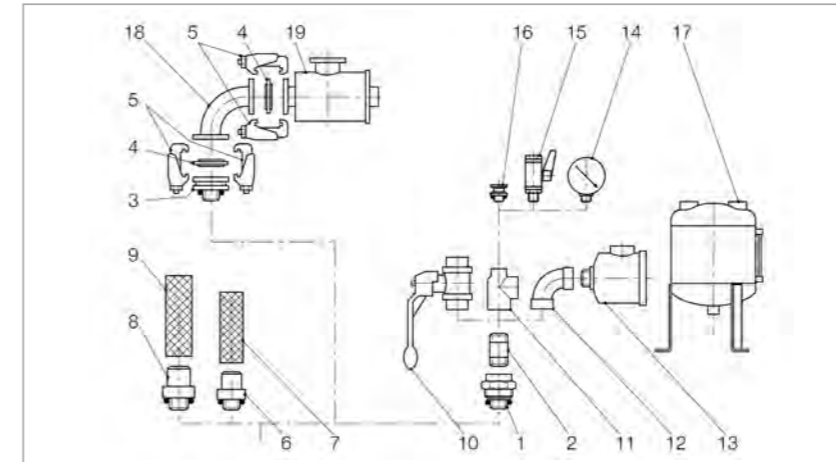

Connection fittings for SOGEVAC SV 200, SV 220B and SV 300 B / SV 320 B

### Technical Data

### Connection Fittings

Item	Description	Connection	Material
1	Screw coupling	G 2" M/F	Aluminium, anodized
2	Double nipple	G 2" M/M – 150 mm (5.9 in.)	Steel
3	Threaded flange adaptor <sup>1)</sup>	G 2" M – DN 63 ISO-K	Steel, zinc coated
4	Centering ring mit Außenring <sup>1)</sup>	DN 63 ISO-K	Aluminium, CR
5	Set of clamping screws DN ISO-K (4 pieces)	M10 x 24	Steel, zinc coated
6	Hose connection <sup>1)</sup>	G 2" M – DN 50 mm (1.97 in.)	Aluminium, anodized
7	PVC tubing	ø 50 mm (1.97 in.), 1 m (3.5 ft) long	PVC
8	Hose connection <sup>1)</sup>	G 2" M – DN 60 mm (2.36 in.)	Aluminium, anodized
9	PVC tubing	ø 60 mm (2.36 in.), 1 m (3.5 ft) long	PVC
10	Ball valve	G 2" F/F	Brass, nickered
11	Tee reducer	G 2" – 2" – 1/2" F/F/F	Gray cast iron
12	Elbow 90°	G 2" F/F	Gray cast iron
13	Dust filter	G 2" M/F	
14	Bourdon vacuum gauge	G 1/2" M	
15	Ball valve	G 1/2" M/F	Brass, nickered/Aluminium
16	Threaded ISO-KF small-flange adapto <sup>1)</sup>	G 1/2" M – DN 16 ISO-KF	Aluminium, anodized
17	Liquid trap	G 2" – 2" – 1/2" F/F/F	
18	Elbow 90°	DN 63 ISO-K	Stainless steel
19	Dust filter with paper cartridge	DN 63 ISO-K	

<sup>1)</sup> inkl. O-Ring

M = Outside thread  
F = Inside thread

## Ordering Information

Item	Description	SV 220 B	Connection Fittings SV 300 B	SV 320 B
		Part No.	Part No.	Part No.
1	Screw coupling	711 18 025	711 18 025	711 18 025
2	Double nipple	11 18 035	11 18 035	11 18 035
3	Threaded flange adaptor <sup>1)</sup>	711 18 126	711 18 126	711 18 126
4	Centering ring mit Außenring <sup>1)</sup>	268 05	268 05	268 05
5	Set of clamping screws DN ISO-K (4 pieces)	267 01	267 01	267 01
6	Hose connection <sup>1)</sup>	711 18 015	711 18 015	711 18 015
7	PVC tubing <sup>2)</sup>	711 18 325	711 18 325	711 18 325
8	Hose connection <sup>1)</sup>	711 18 016	711 18 016	711 18 016
9	PVC tubing	711 18 326	711 18 326	711 18 326
10	Ball valve	711 30 107	711 30 107	711 30 107
11	Tee reducer	711 18 265	711 18 265	711 18 265
12	Elbow 90°	711 18 215	711 18 215	711 18 215
13	Dust filter with paper cartridge with activated charcoal cartridge with metal cartridge with polyester filter cartridge	951 55 711 27 122 711 27 123 711 27 124	951 55 711 27 122 711 27 123 711 27 124	951 55 711 27 122 711 27 123 711 27 124
14	Bourdon vacuum gauge	951 92	951 92	951 92
15	Ball valve	711 30 113	711 30 113	711 30 113
16	Threaded ISO-KF small-flange adapto <sup>1)</sup>	711 18 120	711 18 120	711 18 120
17	Liquid trap	951 44	951 44	951 44
18	Elbow 90°	887 25	887 25	887 25
19	Dust filter with paper cartridge	951 68	951 68	951 68

Special versions for oxygen applications are available upon request

<sup>1)</sup> With NBR-O-Ring

<sup>2)</sup> See "Dust Filters F (Suction Side)" for other options

## Connection Fittings for SOGEVAC SV 630 B(F), SV 750 B(F)

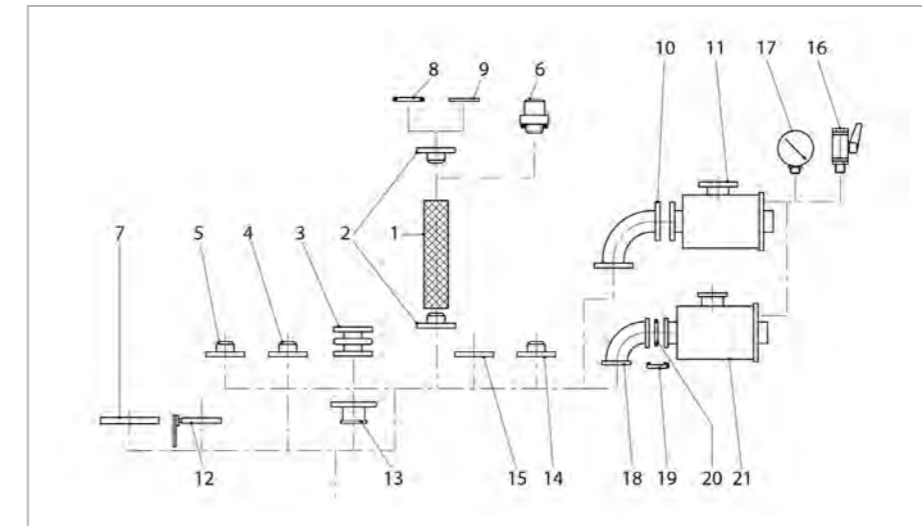

Connection fittings for SOGEVAC SV 630 B(F), SV 750 B(F)

### Technical Data

### Connection Fittings

Item	Description	Connection	Material
1	PVC tubing	90 mm (3.54 in.) dia., 1 m (3.5 ft) long	
2	Hose connection	DN 100 PN 10 – DN 90 mm (3.54 in.)	Steel
3	Coupling	Ø 100 – PN 10	Stainless steel/Aluminium/Rubber
4	Adaptor flange	DN 100 PN 10 – G 4" F	Steel
5	Adaptor flange	DN 100 PN 10 – G 3" F	Steel
6	Adaptor flange	G 4" M – DN 90	Steel/NBR
7	Adaptor for Roots pump	RUVAC 1001 RUVAC 2001 RUVAC WH4400	Steel/NBR Steel/FPM Steel/FPM
8	O-Ring	dia. 110 x 5 (3.94 x 0.2 in.)	NBR
9	Centering ring with O-Ring	DN 100 PN 10 – DN 100 ISO-K	Aluminium/NBR
10	Elbow 90°	DN 100 PN 10	Steel
11	Dust filter F 630	DN 100 PN 10	
12	Manually operated blocking valve	DN 100 PN 10	Gray cast iron
13	Adapter	DN 100 PN 10 – 100 ISO-K	Aluminium
14	Adaptor flange with tubulation	DN 100 PN 10 (tube dia. 108 (4.25 in.))	Steel
15	Collar flange	DN 100 PN 10 – DN 100 ISO-K	Steel
16	Ball valve	G 1/2" M/F	Brass, nickerled/Aluminium
17	Bourdon vacuum gauge	G 1/2" M	
18	Elbow 90°	DN 100 ISO-K	Stainless steel
19	Set of clamps for DN ISO-K Set = 4 pieces	M 10 x 24	Steel, zinc coated
20	Centering ring	DN 100 ISO-K	Aluminium/NBR
21	Dust filter	DN 100 ISO-K	
	Screw set (not drawn) Set = 8 screws and 8 nuts	DN 100 PN 10	Steel, zinc coated

M = Outside thread

F = Inside thread

Ordering Information

Item	Description	Connection Fittings	
		SV 630 B(F)	SV 750 B(F)
		Part No.	Part No.
1	PVC tubing	711 18 329	711 18 329
2	Hose connection	711 18 362	711 18 362
3	Coupling	711 18 342	711 18 342
4	Adaptor flange	711 18 372	711 18 372
5	Adaptor flange	711 18 370	711 18 370
6	Hose connection	711 18 017	711 18 017
7	Adaptor for Roots pump RUVAC 1000 RUVAC 2000 RUVAC WH4400	971 432 340 971 432 350 971 43 WH4400	971 432 340 971 432 350 971 43 WH4400
8	O-ring	712 42 882	712 42 882
9	Centerring ring with O-ring	711 18 391	711 18 391
10	Elbow 90°	711 18 284	711 18 284
11	Dust filter F 630 <sup>1)</sup> with paper cartridge	951 71	951 71
	with activated charcoal cartridge	711 27 162	711 27 162
	with metal cartridge	711 27 163	711 27 163
	with polyester filter cartridge	711 27 164	711 27 164
12	Manually operated blocking valve	711 30 116	711 30 116
13	Adaptor	711 18 336	711 18 336
14	Adaptor flange with tubulation	711 18 351	711 18 351
15	Collar flange	711 18 383	711 18 383
16	Ball valve	711 30 113	711 30 113
17	Bourdon vacuum gauge	951 92	951 92
18	Elbow 90°	887 26	887 26
19	Clamp screws for DN ISO-K Set = 4 pieces	267 01	267 01
20	Centering ring <sup>2)</sup>	268 06	268 06
21	Dust filter <sup>1)</sup> with paper cartridge	951 72	951 72
	with activated charcoal cartridge	711 27 166	711 27 166
	with metal cartridge	711 27 167	711 27 167
	with polyester cartridge	711 27 168	711 27 168
	Screw set (not drawn) Set = 8 screws and 8 nuts	714 12 440	714 12 440

Special versions for oxygen applications are available upon request

<sup>1)</sup> See "Dust Filters F (Suction Side)" for other options

<sup>2)</sup> incl. O-ring

# Only available for purchase in North and South America 60 Hz Curves

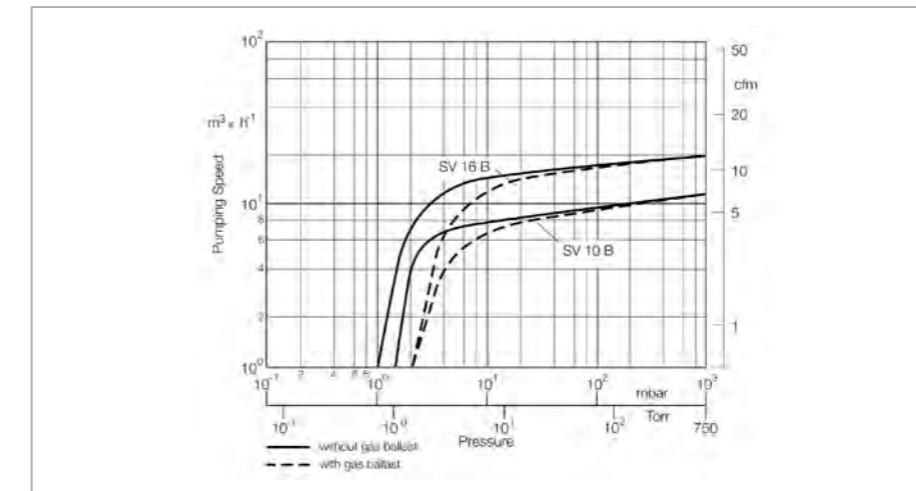

Pumping speed characteristics for the SOGEVAC SV 10 B and SV 16 B at 60 Hz

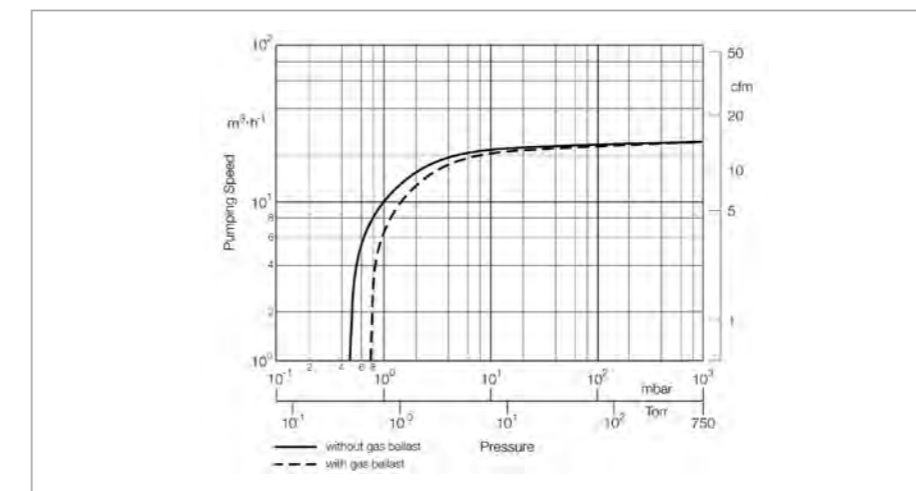

Pumping speed characteristics for the SOGEVAC SV 25 B at 60 Hz

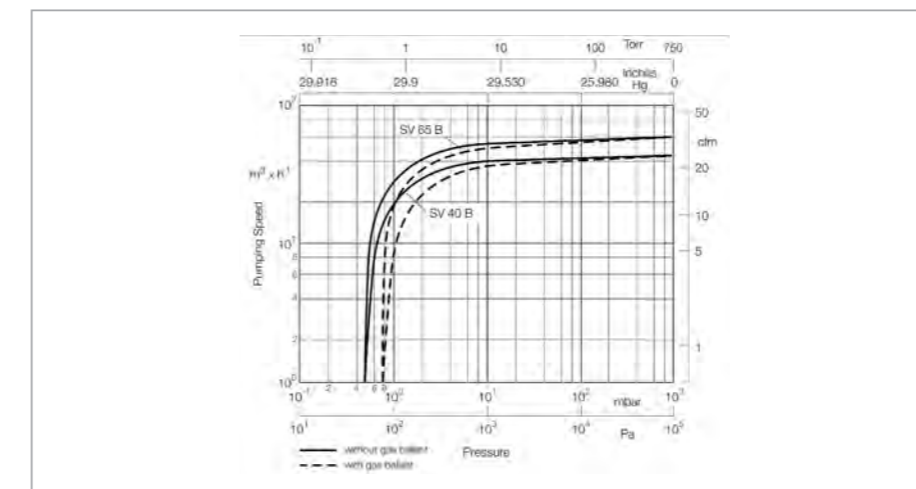

Pumping speed characteristics for the SOGEVAC SV 40 B and SV 65 B at 60 Hz

# Only available for purchase in North and South America

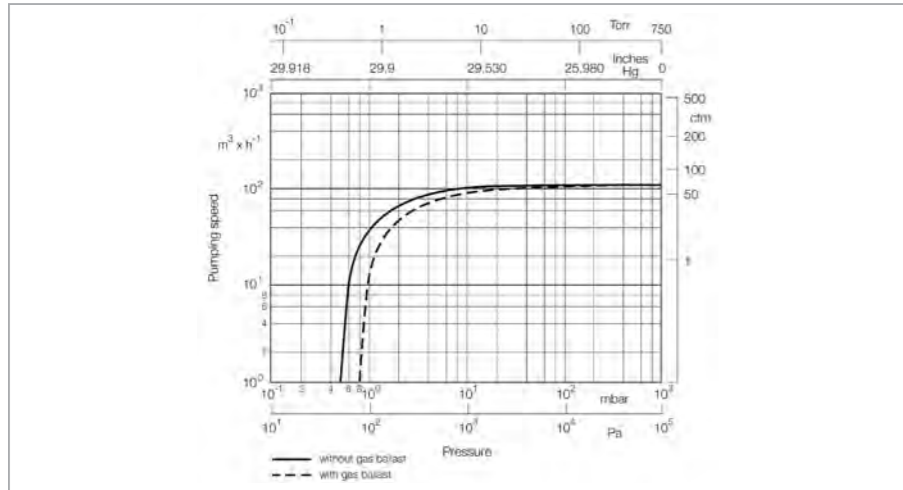

Pumping speed characteristics for the SOGEVAC SV 100 B at 60 Hz

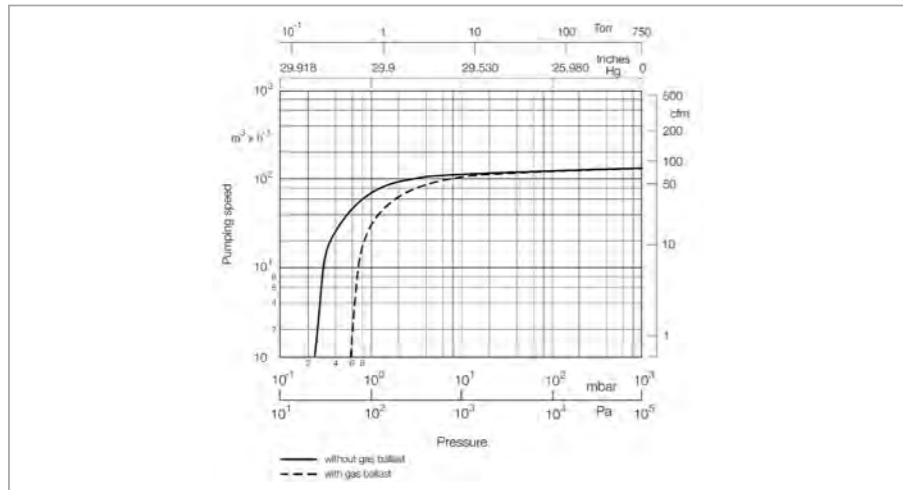

Pumping speed characteristics for the SOGEVAC SV 120 B at 60 Hz

# Only available for purchase in North and South America

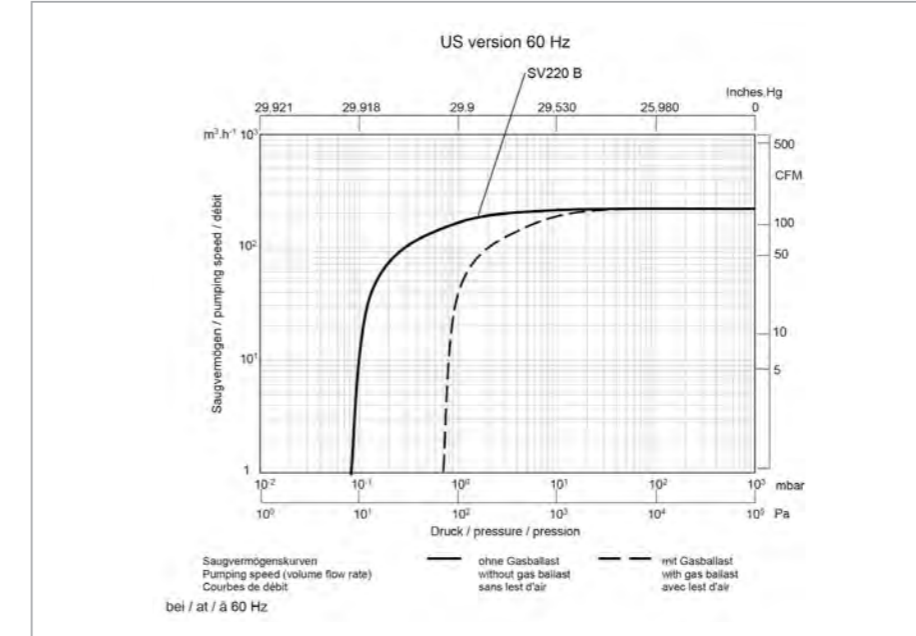

Pumping speed characteristics for the SOGEVAC SV 220 B at 60 Hz

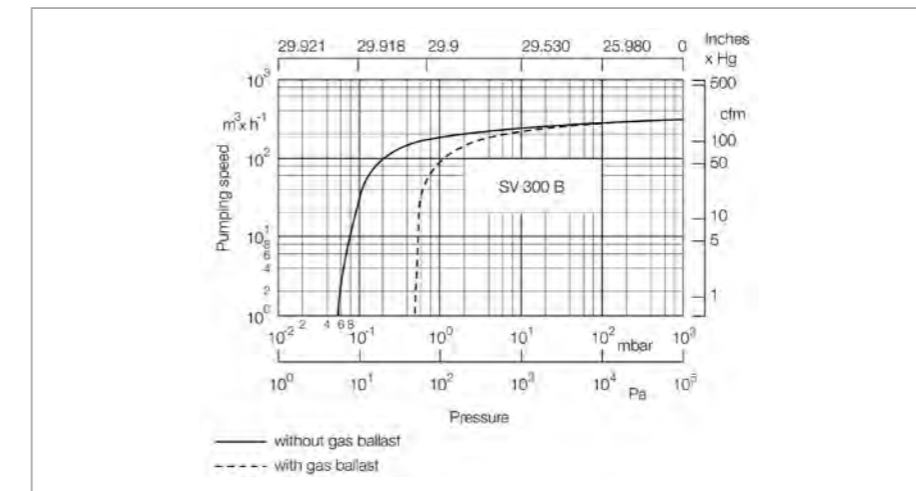

Pumping speed characteristics for the SOGEVAC SV 300 B at 60 Hz

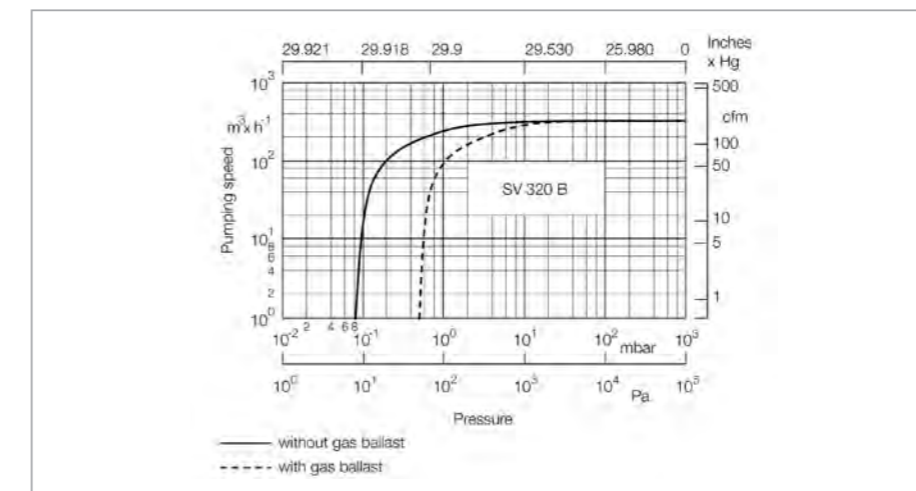

Pumping speed characteristics for the SOGEVAC SV 320 B at 60 Hz

# Only available for purchase in North and South America

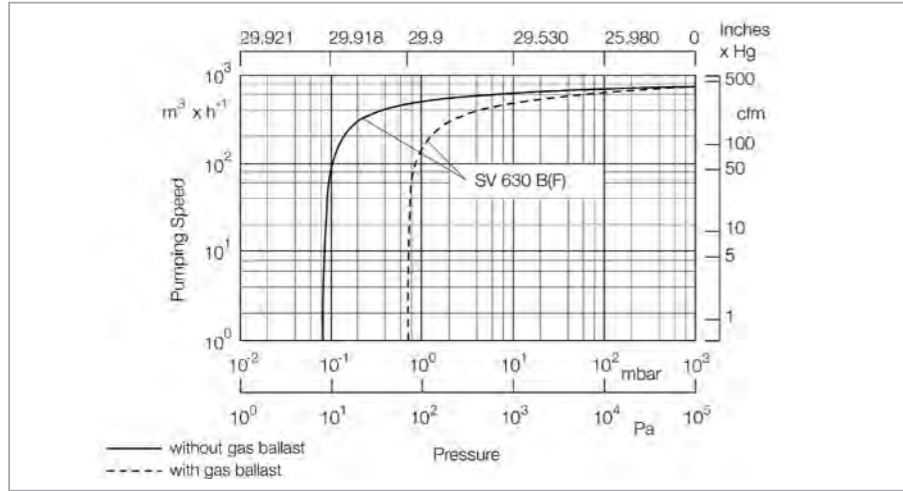

Pumping speed characteristics for the SOGEVAC SV 630 B(F) at 60 Hz

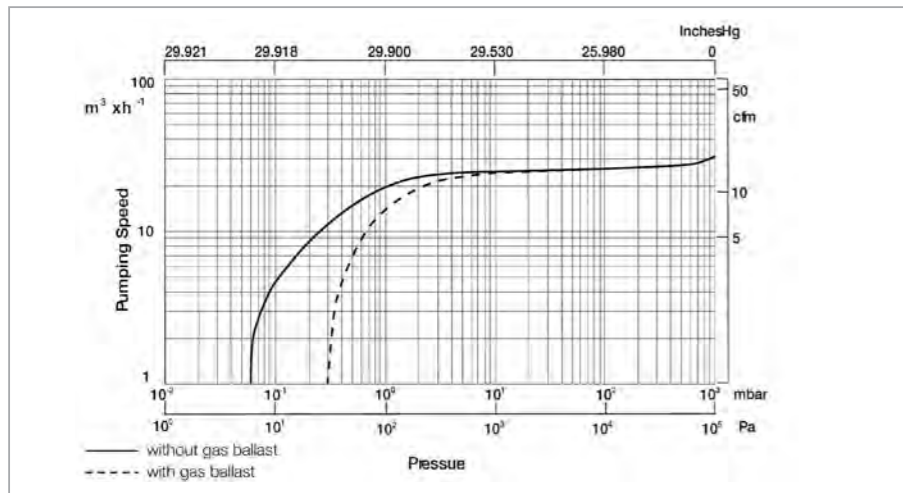

Pumping speed characteristics for the SOGEVAC SV 28 BI at 60 Hz

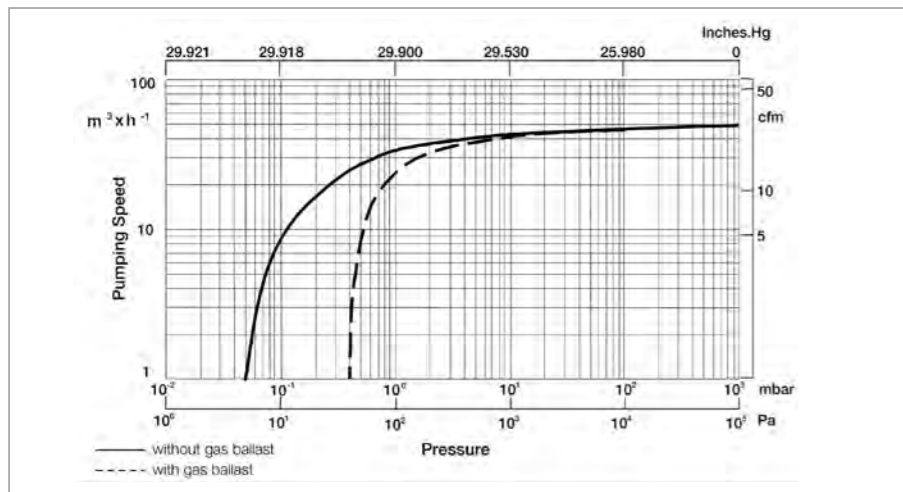

Pumping speed characteristics for the SOGEVAC SV 40 BI at 60 Hz

# Only available for purchase in North and South America

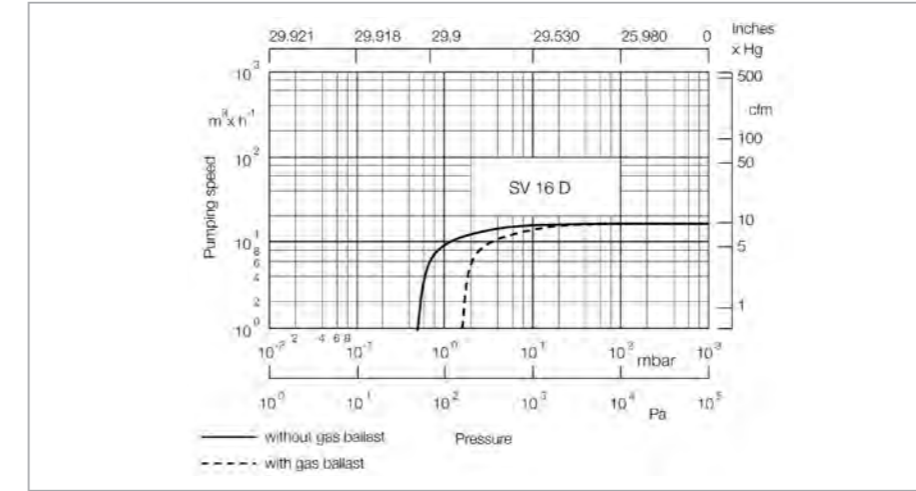

Pumping speed characteristics of the SOGEVAC SV 16 D at 60 Hz

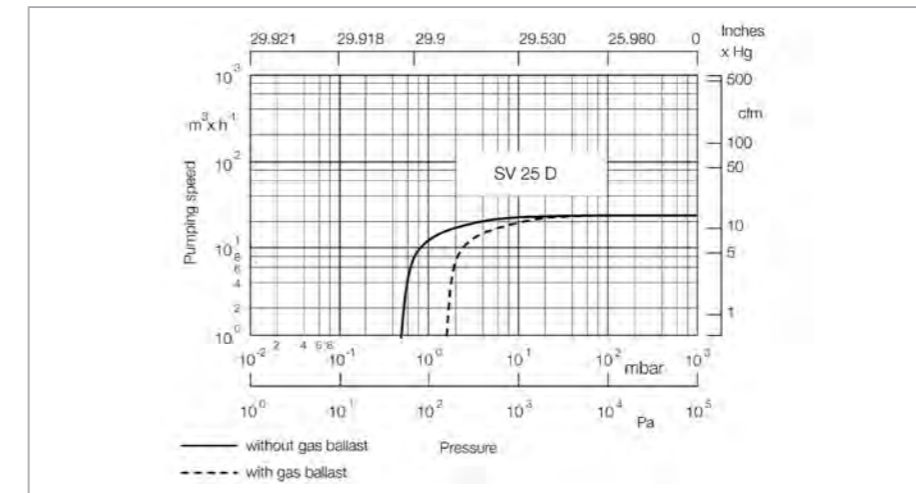

Pumping speed characteristics of the SOGEVAC SV 25 D at 60 Hz

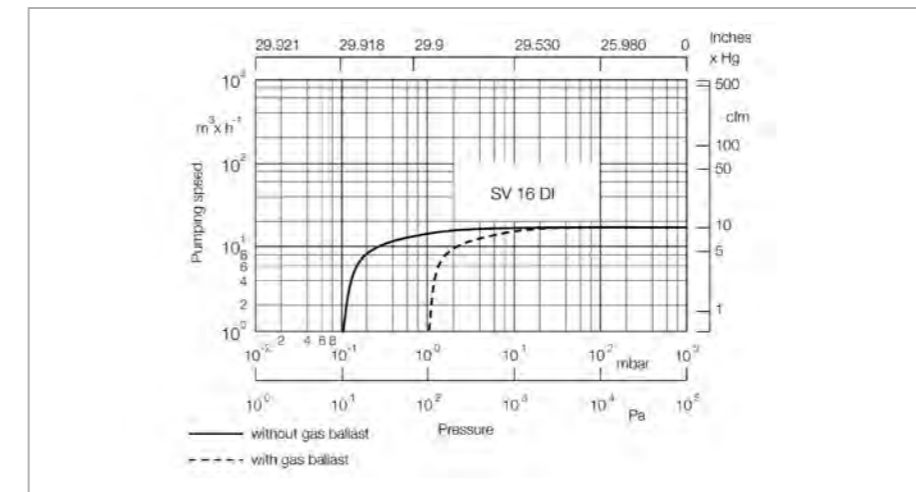

Pumping speed characteristics of the SOGEVAC SV 16 DI at 60 Hz

# Only available for purchase in North and South America

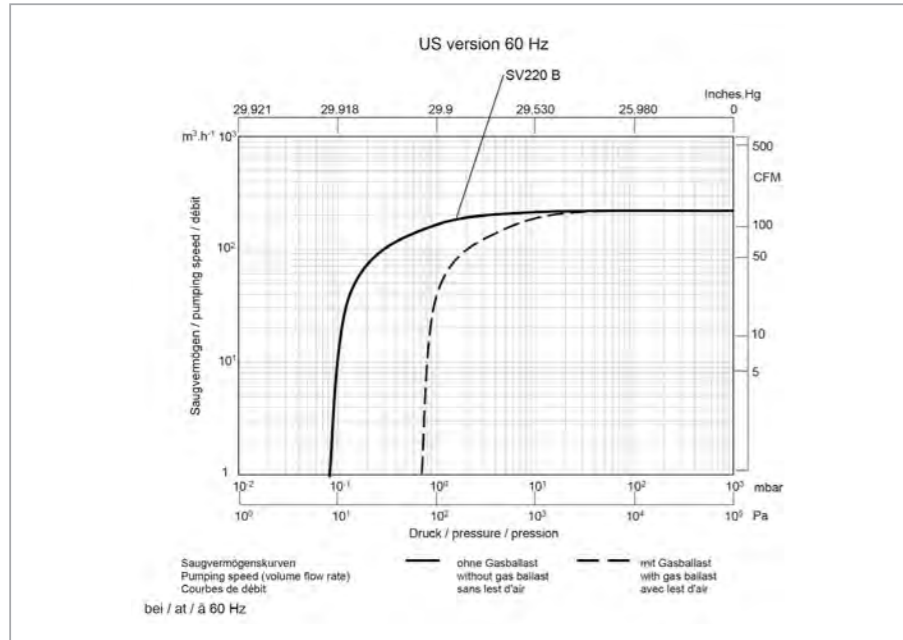

Pumping speed characteristics for the SOGEVAC SV 220 B at 60 Hz

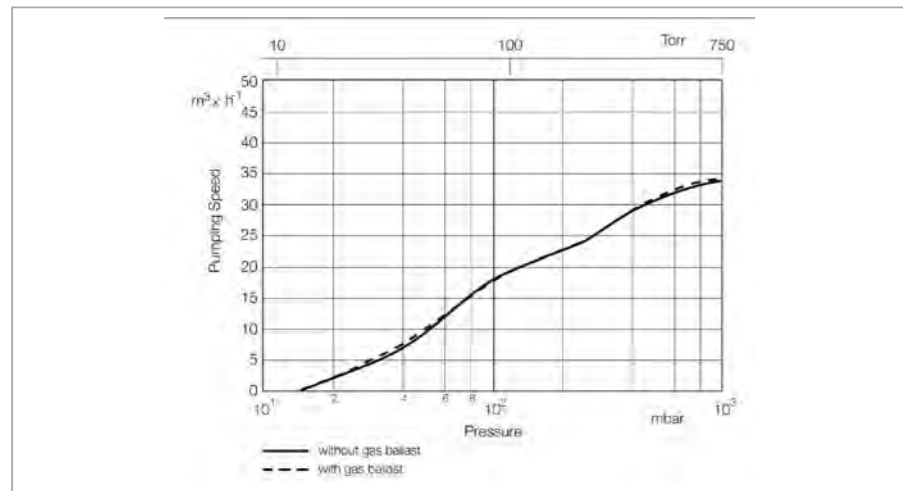

Pumping speed characteristics of the SOGEVAC SV 40 ATEX at 60 Hz for gases of the material group IIB and H<sub>2</sub>

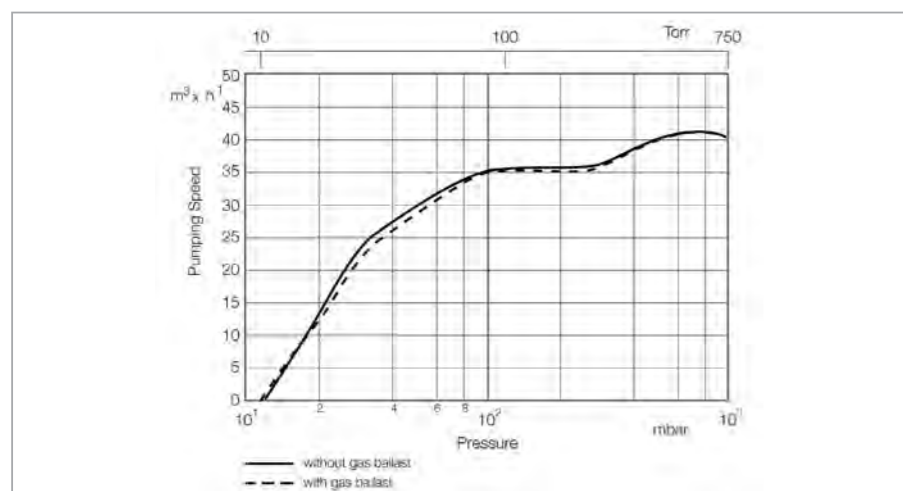

Pumping speed characteristics of the SOGEVAC SV 40 ATEX at 60 Hz for gases of the material group IIA

# Only available for purchase in North and South America

## Combination Filter Vacuum Pump Inlet Filter



Combination filter

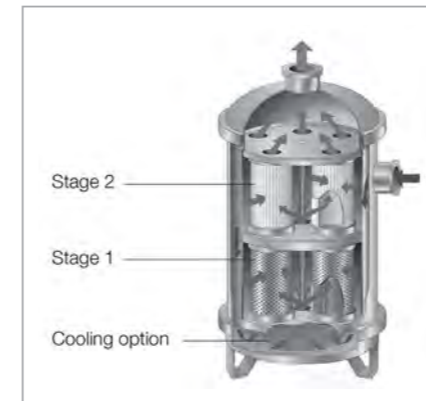

Combination filter: cutaway view

The combination filter is a high efficiency vacuum pump inlet filter designed specifically to condense, absorb, and neutralize process byproducts generated from vacuum applications in the chemical and pharmaceutical industries.

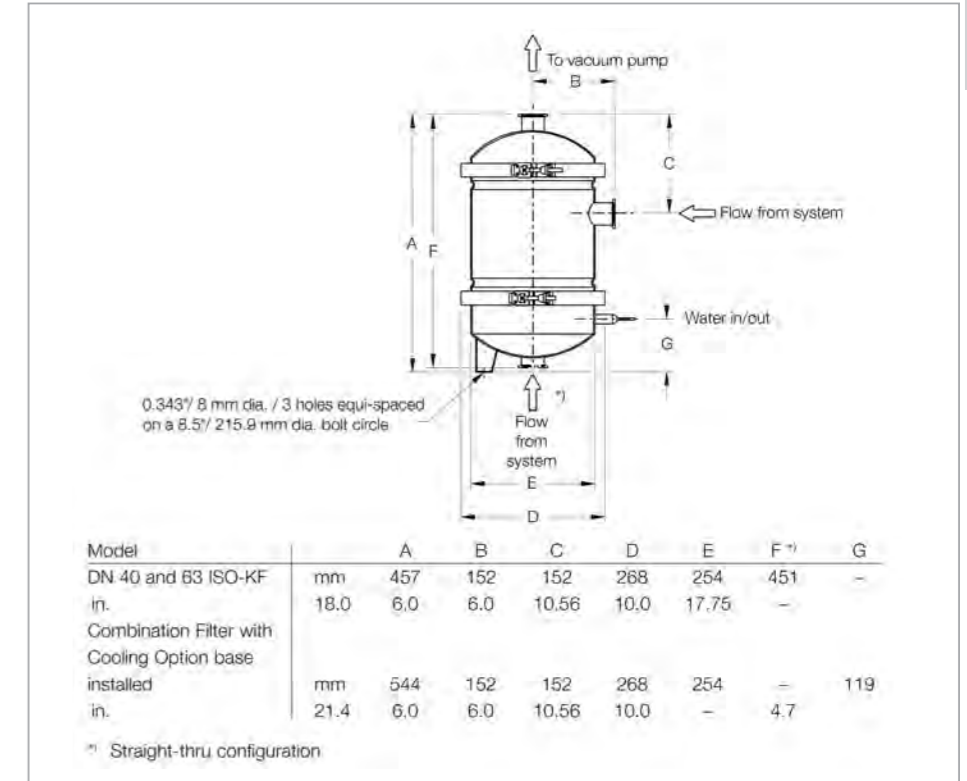

Dimensional drawing for the combination filter

### Advantages to the User

- All stainless steel construction withstands corrosive environments
- Modular design allows for numerous configurations and easy servicing
- Stacking modules available for increased capacity
- Optional drain port for solvent draining and reclamation
- Customizable absorption/neutralization stages for optimal efficiency

- Processes such as distillation, drying, degassing, central lab vacuum protection
- Cooling option: Large cooled surface area for condensing of solvents, acids and water vapor

### Specifications

- Cooling option: Large cooled surface
- Upper and lower seals in Buna N and Viton



Combination filter: cutaway view

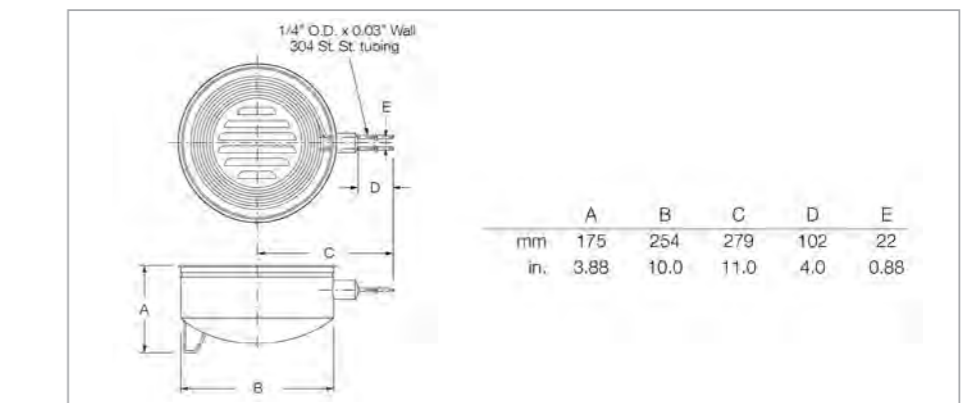

Dimensional drawing for the combination filter Cooling Option

### Ordering Information

### Connection Fittings

DN 40 ISO-KF      DN 63 ISO-K

	Part No.	Part No.
Combination filter 5 filter elements in stage 1 and 5 elements in stage 2 (elements not included)	180497V	180499V
straight-thru configuration, same as above except inlet on bottom	180498V	-
Stacking modules includes 2 stages (5 elements ea.), 11.25" (286 mm) tall, all attachment hardware included (filter elements not included)	180500V	180500V
Cooling Option base, 0.5 – 1.0 GPM (2 – 4 LPM) water flow recommended	180501V	180501V

### Ordering Information

### Filter Elements

	Part No.
Copper gauze	180502V
Stainless steel gauze	180503V
Molecular sieve	180504V
Porous mixture of sodium hydroxide and potassium hydroxide	180505V
Activated charcoal	180506V
Pleated polypropylene 2 micron (99% efficient)	180507V
Pleated polypropylene 5 micron (99% efficient)	180508V
Pleated polypropylene 20 micron (99% efficient)	180509V

### Ordering Information

### Adapters (Stainless Steel)

	Part No.
DN 40 ISO-KF to 1 1/4" NPT (male)	899 627
DN 40 ISO-KF to 2" NPT (male)	899 629
DN 63 ISO-K to 2" NPT (male)	721 03 040

## Products

### Oil-sealed Screw Vacuum Pumps VACUBE VQ 400 i to VQ 4800 iH



VACUBE VQ models

VACUBE is a new generation of intelligent, single-stage, oil sealed screw vacuum pumps with Variable Speed Drive (VSD) technology.

VACUBE generates vacuum on demand. All pumps are controlled and maintained by an internal controller. The systems offer superior performance for a wide range of rough vacuum applications.

#### Models

##### i – model

Ideal for low-vapor free applications as needed in central vacuum systems for holding, lifting and moving of parts and components.

##### iH – model

This variant is best suited for applications with high water vapor ingress. The high water vapor tolerance level makes the iH – model best suited for the humid applications.

##### iC – model

The iC – VACUBE variant is specifically designed to support the special needs in short cycling applications, as for example common in vacuum packaging or assembly lines for electronic equipment.

##### iCH – model

The combination of „iH“ and „iC“ offers high water vapor tolerance and the short cycling ability.

#### Advantages to the User

- **Pump efficiency**
  - Variable speed with on-board frequency controller (FC)
  - Smart controller with intuitive interface
- **Power demand**
  - Sustainable power saving due to on-demand vacuum generation
- **Work space environment**
  - Ultra-high oil retention system
  - Quiet operation, noise level bench mark
  - Small footprint – pallet size dimensions\* (\*up to 790 m<sup>3</sup>/h speed)
  - “Plug and pump” system set up
- **Sustainable productivity**
  - Programable operation modes
  - Long maintenance intervals
- **Typical Applications**
  - **Holding, lifting and moving**
    - Print & Paper
    - Packaging
    - Electronic manufacturing
  - **Woodworking**
  - **Li-Ion cell manufacturing**
  - **Glass manufacturing**
  - **Forming and shaping**
    - Plastics (e.g. bath tubs, shower trays, white goods internals)
    - Packaging materials (e.g. thermoformed parts)
    - Glass items such as bottles and windscreens
    - Wood lamination
  - **Food applications**
    - Meat packaging (skin, modified atmosphere packaging MAP)
    - Poultry packaging
    - Canning
    - Food freeze drying
  - **Dehumidification**
    - Vacuum cooling
    - Roof tile and brick manufacture
    - Pipeline drying
  - **Special demands**
    - Altitude testing
    - Special evacuation duties
    - Coating
    - Clean environments

# On-Board Controllers

## Central Controller Multi-VAControl

Every VACUBE comes with an on-board controller as standard. Two controller platforms are available, MK5 and Leybold VAControl®.



VACUBE with MK5 controller



VACUBE with Leybold VAControl® controller

### Central controller Multi-VAControl

When one pump is not enough, we offer a complete system with multiple VACUBE pumps, all centralized together via the Multi-VAControl central controller.

#### Advantages to the User

- An easy-to-install solution for central vacuum systems: the central controller and the pumps are connected by communication cables
- Pump redundancy: the spare pump can also be connected to the central vacuum, and managed by the Multi-VAControl
- A highly-connected system: we offer local or cloud connectivity
- A future-proof set-up: more pumps can be added easily when your needs increase

### MK5 Controller

The MK5 controller offers 1st generation smart controls to our VACUBES:

- Setpoint pressure control
- Temperature management
- Gas ballast management
- Alarms and warnings
- Timers and work period calendar
- Maintenance intervals follow-up

VACUBES with the MK5 controller can also be connected to a PLC via fieldbus. Moreover, it is possible to look up the screen parameters from a local Ethernet connection.

### Leybold VAControl® Controller

The Leybold VAControl® controller takes VACUBE to another dimension. All features of the MK5 controller remain available. VAControl adds performance and connectivity to help you manage your VACUBE in the most efficient way:

- Check, use or program your VACUBE from remote, whether you want to use local access, Wi-Fi, LAN or Cloud communication
- Your VACUBE records and processes its own performance data, to help you with diagnostics
- Monitor your vacuum performance and your energy efficiency in an intuitive way

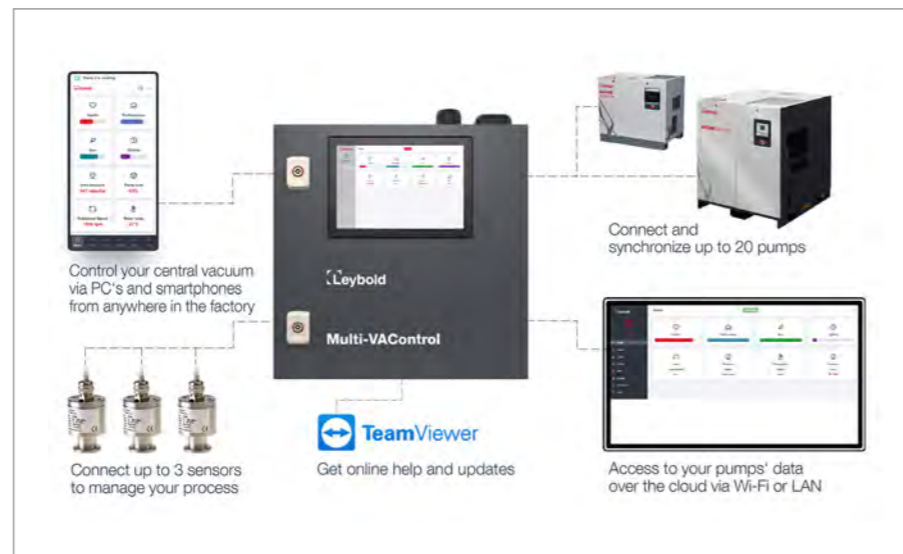

Synchronization example of multiple VACUBE pumps with Multi-VAControl

# VACUBE 400 to 800 m<sup>3</sup>/h

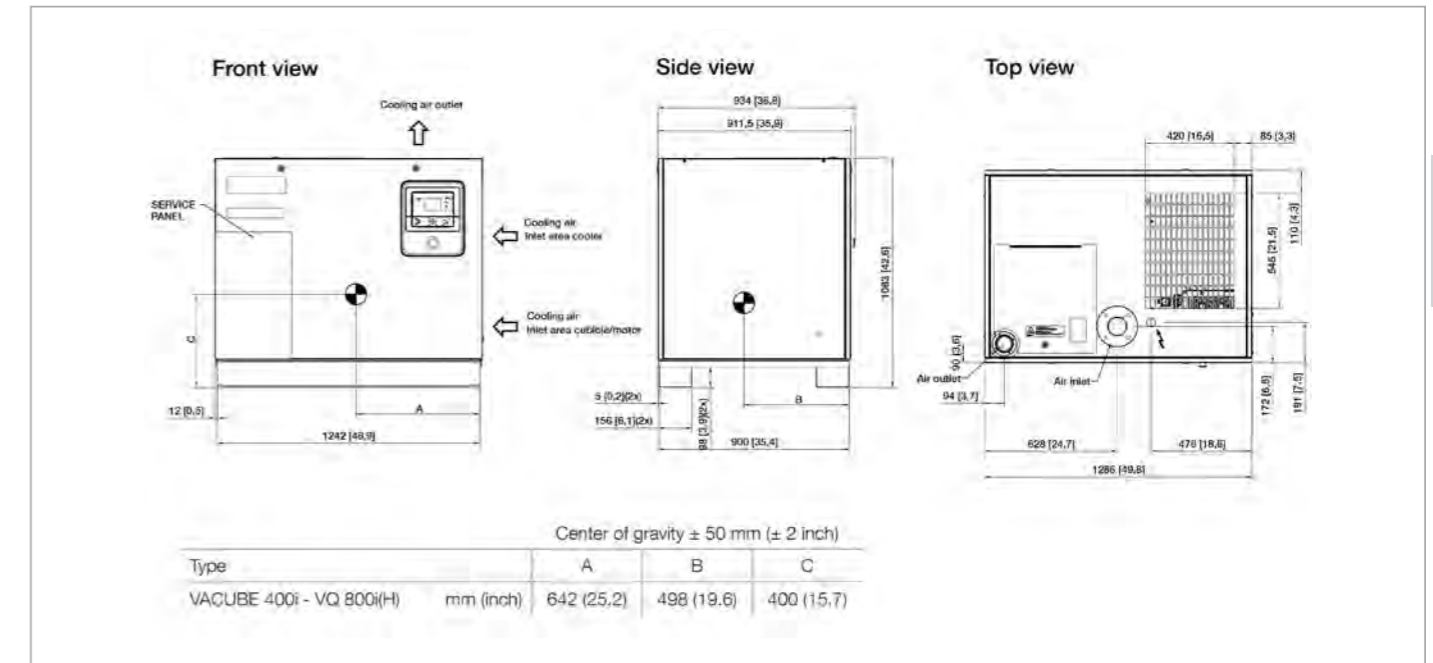

Dimensional drawing VACUBE VQ 400i - VQ 800i(H) - all dimensions in mm

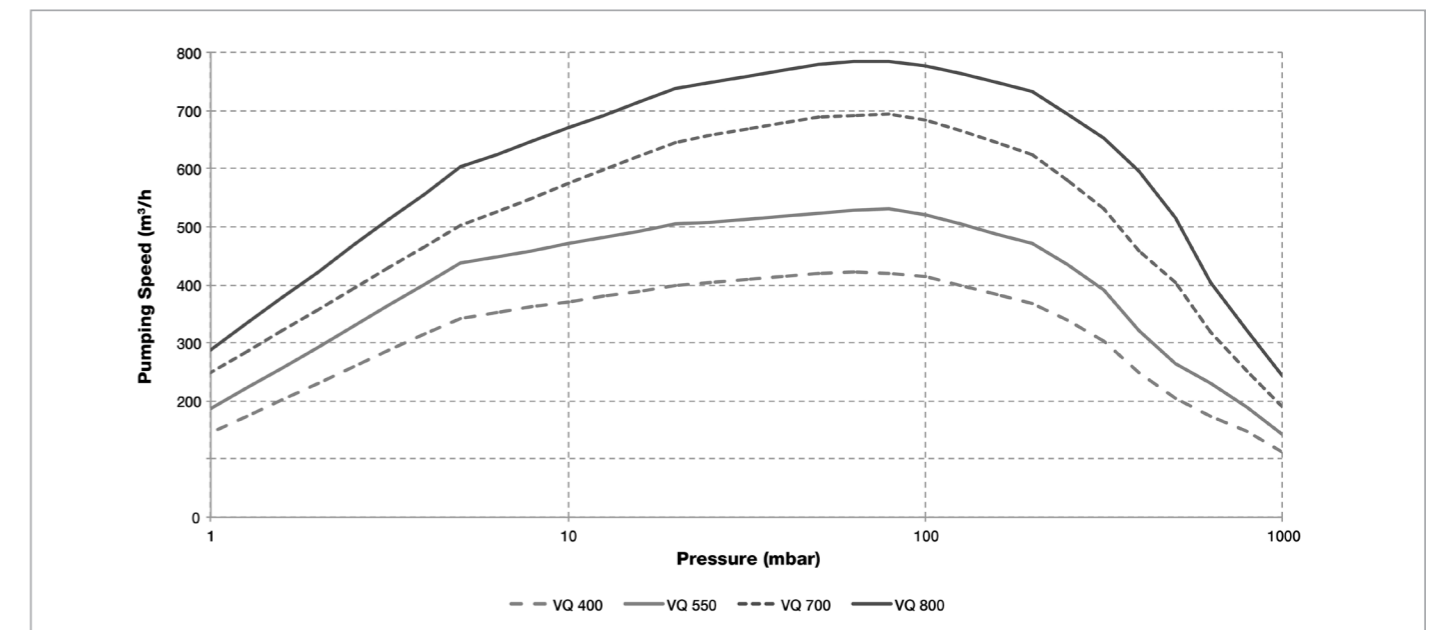

Pumping speed characteristics VACUBE VQ 400i - VQ 800i(H)

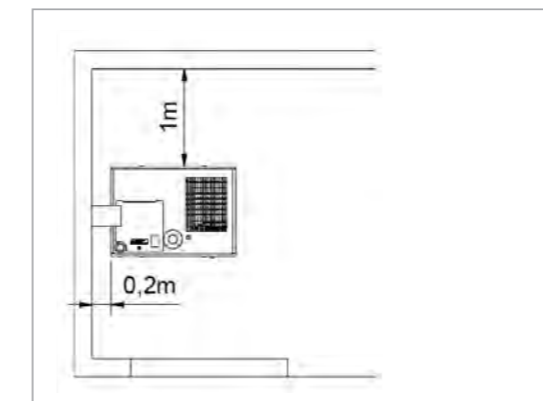

Installation requirements VACUBE VQ 400i - VQ 800i(H)

**Technical Data**

		<b>VACUBE</b>			
		<b>VQ 400</b>	<b>VQ 550</b>	<b>VQ 700</b>	<b>VQ 800</b>
Max. eff. pumping speed <sup>1)</sup>	m <sup>3</sup> /h (cfm)	420 (247)	530 (310)	700 (412)	790 (465)
Ultimate pressure <sup>1)</sup>	mbar (Torr)	0.35 / 0.26			
Optimal pressure range <sup>1)</sup>	mbar (Torr)	5-400 (3.75-300)			
Controller type		VAControl			
Motorshaft power	kW (hp)	5.5 / 7.5	7.5 / 10	11 / 15	15 / 20
Noise level	dB(A)	51 – 65		51 – 73	51 – 76
Ambient temperature	°C (°F)	0 – 46 (32 – 115)			
Weight	kg (lbs)	500 / 1102		510 / 1125	520 / 1147
Protection class	IP	54			
Supply voltages		380 – 460 V, 3ph, 50/60Hz			
Pump cooling		Air-cooled, vertical cooling air flow			
Inlet flange	DN	80 PN 10			
Exhaust flange	DN	65 non std.			

<sup>1)</sup> To DIN 28 400 and following numbers

**Ordering Information**

		<b>VACUBE</b>			
		<b>VQ 400</b>	<b>VQ 550</b>	<b>VQ 700</b>	<b>VQ 800</b>
		<b>Part No.</b>	<b>Part No.</b>	<b>Part No.</b>	<b>Part No.</b>
i - Model with front panel		10770400V01	10770550V01	10770700V01	10770800V01
iH - Model with front panel		10770400V10	10770550V10	10770700V10	10770800V10
i - Model with HMI		10770400V05	10770550V05	10770700V05	10770800V05
iH - Model with HMI		10770400V15	10770550V15	10770700V15	10770800V15

**Accessories**

Multi-VAControl <sup>®</sup> central controller	10430001V01			
Wi-Fi option for VACUBE or Multi-VAControl <sup>®</sup>	3002615051			
NPT 3" threaded inlet	177005A50			
NPT 2-1/2" threaded outlet	177005A60			
Manual inlet valve for VQ400-800	177005A78			
Power transformer 200-230 V	177005A80	177005A82	177005A83	
Power transformer 500-575 V	177005A84	177005A86	177005A87	

# VACUBE 1250 to 1650 m<sup>3</sup>/h

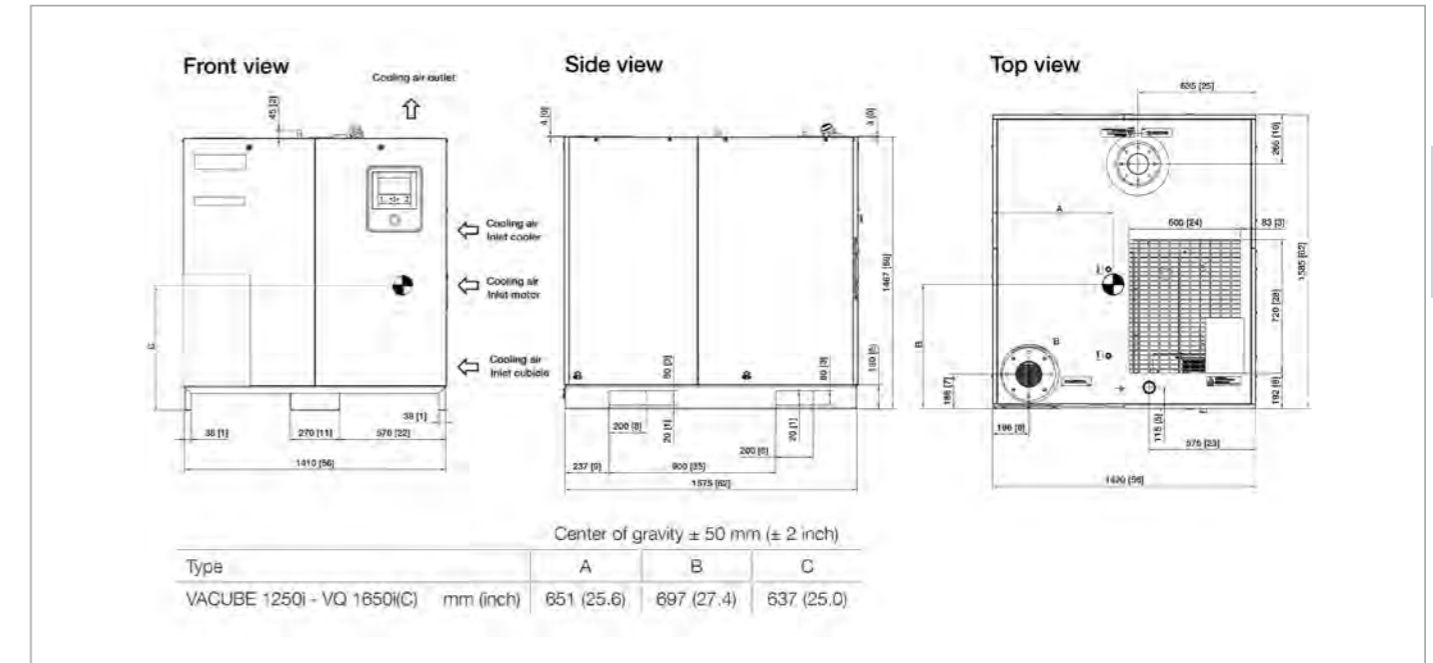

Dimensional drawing VACUBE VQ 1250i - VQ 1650i(C) - all dimensions in mm

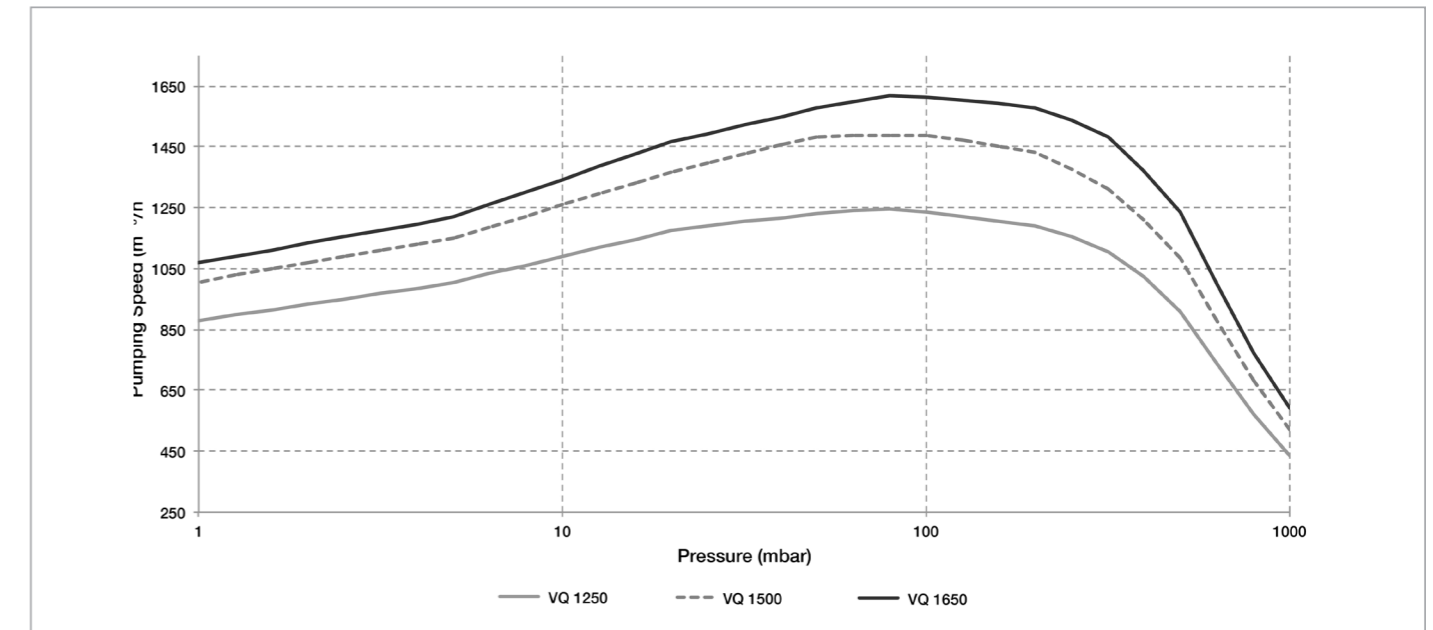

Pumping speed characteristics VACUBE VQ 1250i - VQ 1650i(C)

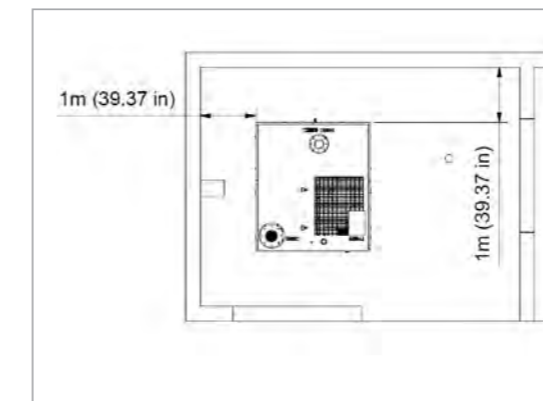

Installation requirements  
VACUBE VQ 1250i - VQ 1650i(C)

**Technical Data**

		VQ 1250	VACUBE VQ 1500	VQ 1650
Max. eff. pumping speed <sup>1)</sup>	m <sup>3</sup> /h (cfm)	1250 (736)	1490 (877)	1620 (955)
Ultimate pressure <sup>1)</sup>	mbar (Torr)	0.35 / 0.26		
Optimal pressure range <sup>1)</sup>	mbar (Torr)	5-400 (3.75-300)		
Controller type		MK5		
Motorshaft power	kW (hp)	22 / 29	30 / 40	37 / 50
Noise level	dB(A)	65 - 75		
Ambient temperature	°C (°F)	0 - 46 (32 - 115)		
Weight	kg (lbs)	1058 / 2333	1073 / 2366	
Protection class	IP	54		
Supply voltages		380 - 460 V, 3ph, 50/60Hz		
Inlet flange	DN	150 PN 10		
Exhaust flange	DN	100 PN 10		

<sup>1)</sup> To DIN 28 400 and following numbers

**Ordering Information**

	VQ 1250	VACUBE VQ 1500	VQ 1650
	<b>Part No.</b>	<b>Part No.</b>	<b>Part No.</b>
i - Model air cooled	177125V01QD	177150V01QD	177165V01QD
iC - Model air cooled	-	177150V05QD	177150V05QD
iH - Model air cooled	177125V10QD	177150V10QD	177165V10QD
iCH - Model air cooled	-	177150V15QD	177165V15QD
i - Model air cooled	177125V02QD	177150V02QD	177165V02QD
iC - Model air cooled	-	177150V06QD	177165V06QD
iH - Model air cooled	177125V11QD	177150V11QD	177165V11QD
iCH - Model air cooled	-	177150V16QD	177165V16QD

**Accessories**

High accuracy pressure transducer	177005A04		
Gateway connection VQ CAN - Profibus	177005A07		
Remote pressure sensor 4-20 mA	177005A08		
G threaded outlet	177005A45		
NPT threaded outlet	177005A65		
Manual inlet valve	177005A79		
Power transformer 200-230 V	177005A88	177005A89	177005A90
Power transformer 500-575 V	177005A91	177005A92	177005A93
Energy recovery system air-cooled	177005A98		

VACUBE 3600 to 4800 m<sup>3</sup>/h

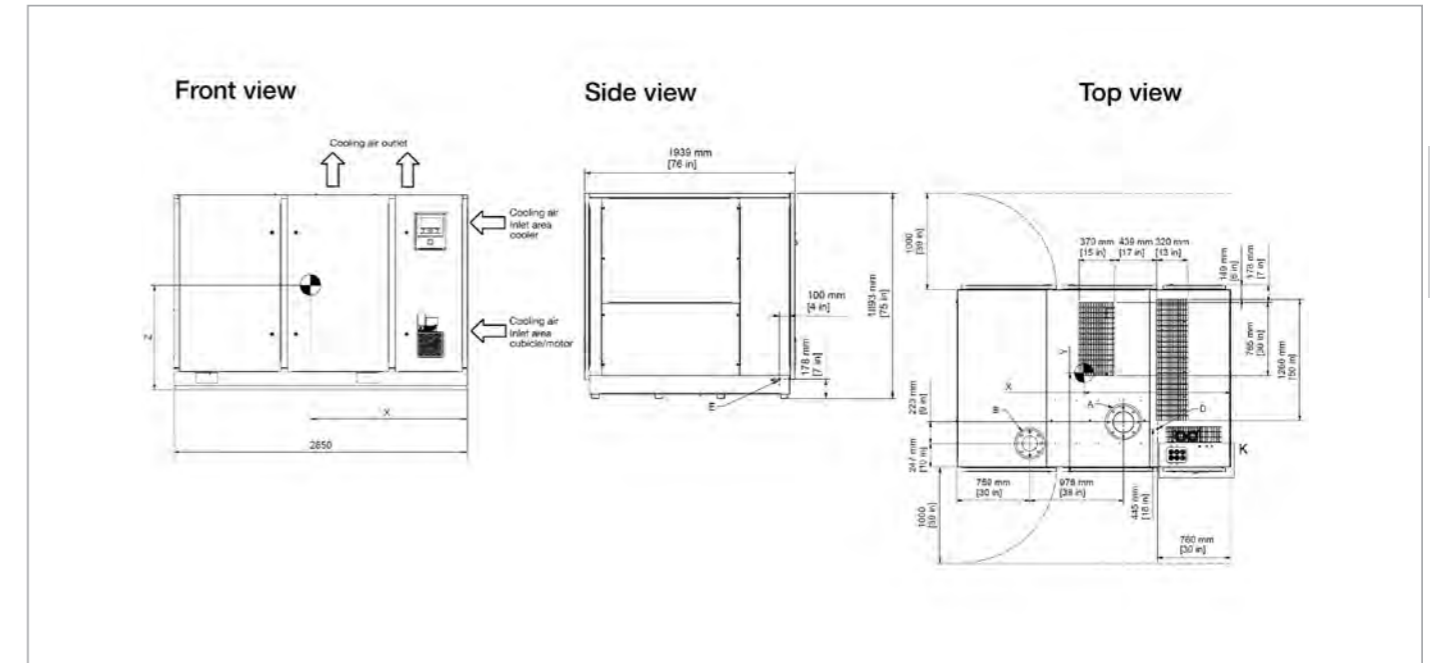

Dimensional drawing VACUBE VQ 3600i - VQ 4800i(H) - all dimensions in mm

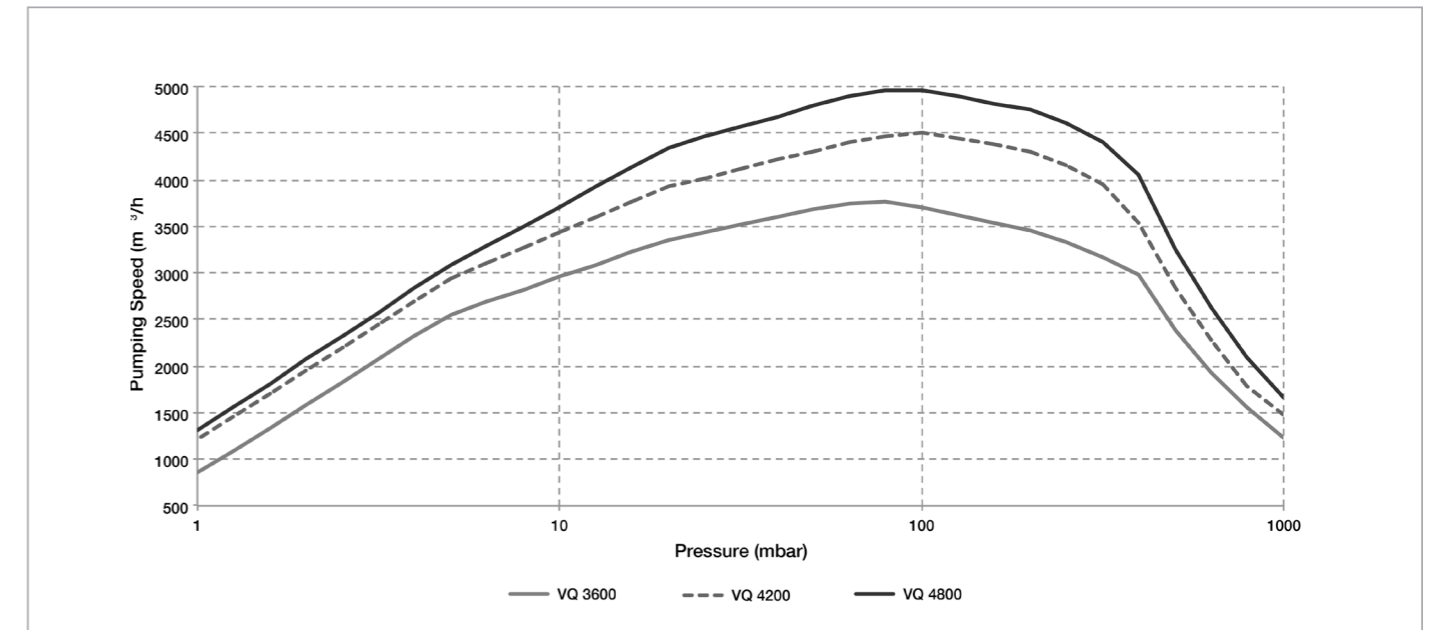

Pumping speed characteristics VACUBE VQ 3600i - VQ 4800i(H)

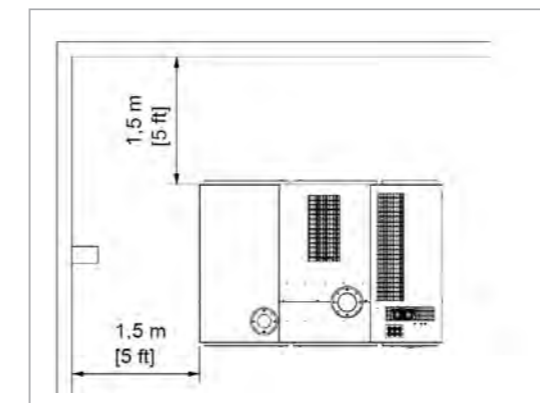

Installation requirements VACUBE VQ 3600i - VQ 4800i(H)

