

Roots Vacuum Pumps

RUVAC

Roots Vacuum Pumps

230.00.02

Excerpt from the Leybold Full Line Catalog (Edition 2022)

Catalog Part Roots Vacuum Pumps

Contents

Roots Vacuum Pumps

General

Applications and Accessories	4
Oil for RUVAC Pumps	
for different fields of application.....	5
for different pump types.....	5
General Information on Roots Vacuum Pumps.....	6
Types.....	9

Products

RUVAC WA/WAU	
Roots Vacuum Pumps with Air-Cooled Flange-Mounted Motors.....	12
RUVAC WS/WSU	
Roots Vacuum Pumps with Air-Cooled Canned Motor.....	18
RUVAC WH/WHU Roots Vacuum Pumps	
with Water-Cooled Hermetically Sealed Motors	24

Accessories

Pressure Switches	32
Temperature Sensor Pt100.....	32

Genuine Maintenance Spare Parts and Kits

Spare Parts and Kits.....	33
---------------------------	----

Miscellaneous

Services	34
----------------	----

General

Applications and Accessories for RUVAC Pumps

Roots Vacuum Pumps	WA/WAU 251	WA/WAU(H) 501-2001	WS/WSU 251	WS/WSU(H) 501-2001	WH 700	WH/WHU 2500/4400/7000
Applications						
Semiconductor production			■			
Vacuum coating	■		■	■	■	
Large scale research		■			■	
Chemistry/Pharmaceutica	■					
Metallurgy/Furnaces	■	■	■	■	■	
Lamps and tubes manufacturing		■				
Packaging	■					
Central vacuum supply systems	■	■	■	■	■	
Freeze drying	■	■	■	■		
Leak testing systems		■	■	■	■	
Electrical engineering	■	■	■	■	■	
High purity gases/closed refrigerant cycles		■	■	■	■	
Mechanical engineering	■	■	■	■	■	
Automotive industry	■	■	■	■	■	

Accessories

Frequency converters	■	■	■	■	■	
Pressure switches	■	■	■	■	■	
Temperature sensor Pt100	■ ¹⁾					

¹⁾ For ATEX pumps only

Oil for RUVAC Pumps for different fields of application

LEYBONOL Oils

	LVO 100	LVO 210	LVO 400
Applications			
Semiconductor production	▲	●	■
Vacuum coating	■	●	●
Research and development	■	●	●
Chemistry/Pharmaceutical	■	●	●
Metallurgy/Furnaces	■	●	▲
Lamps and tubes manufacturing	■	●	
Packaging	■	●	
Central vacuum supply systems	■	●	
Freeze drying	■	●	▲
Leak testing systems	■		
Electrical engineering	■		
High purity gases/closed refrigerant cycles	■		
Mechanical engineering	■		
Automotive industry	■	●	●

■ = Standard
 ● = Possible
 ▲ = Please contact Leybold

The table only lists general applications. Your specific requirements might be subject to deeper analysis. For further questions, please contact our technical Sales support.

Oil for RUVAC pumps for different pump types

LEYBONOL Oils

	LVO 100	LVO 210	LVO 400
Pumps			
WA/WAU 251	■	●	●
WA/WAU(H) 501-2001	■	●	●
WS/WSU 251	■	●	●
WS/WSU(H) 501-2001	■	●	●
WS 501 W	■	●	●
WS/WSU 1001 and 2001 W	■	●	●
WH 700		■	●
WH/WHU 2500		■	●
WH/WHU 4400/7000	●	■	●

■ = Standard
 ● = Possible

For information on oil specifications please refer to Catalog Part "Oils / Greases / Lubricants LEYBONOL®".

General Information on Roots Vacuum Pumps

Applications

For many years now Roots vacuum pumps have been well established in the area of vacuum technology. In combination with backing pumps, which compress against the atmosphere, these pumps offer the following advantages:

Shifting the Operating Pressure into the High Vacuum Range

As a rule of the thumb one may say that Roots vacuum pumps are capable of improving the attainable ultimate pressure of a pump system by a factor of 10. With two Roots vacuum pump stages and a corresponding backing pump it is possible to attain pressures in the range down to 10^{-5} mbar (0.75×10^{-5} Torr). Under certain circumstances this will make the use of additional high vacuum pumps (turbo-molecular pumps or diffusion pumps) unnecessary.

Multiplied Pumping Speed

Due to the non-contact rotation of the impellers, Roots vacuum pumps are able to run at higher speeds. Thus a high pumping speed is obtained with a relatively small size pump. Pumping speeds in excess of $1500 \text{ m}^3/\text{h}$ (589 cfm) can only be attained with Roots vacuum pumps.

When selecting the right kind of backing pump (sizing) it will be possible to pump large quantities of gas in connection with smaller backing pumps. Energy consumption of such a pump system is much less compared to a single backing pump offering the same pumping speed.

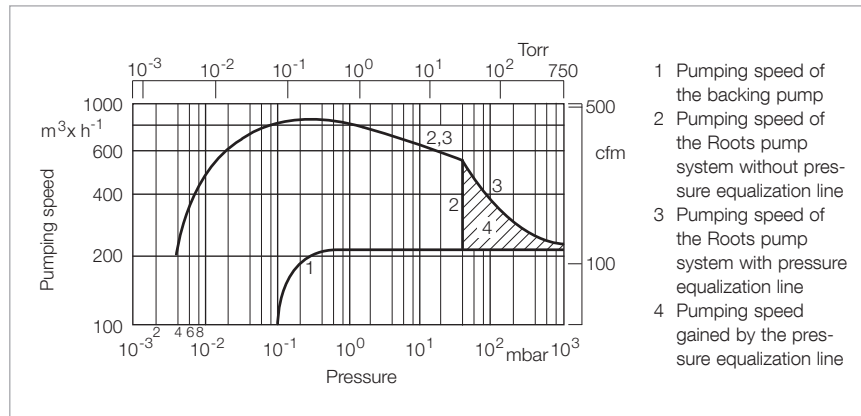

Comparison of pumping speed characteristics with and without pressure equalization line

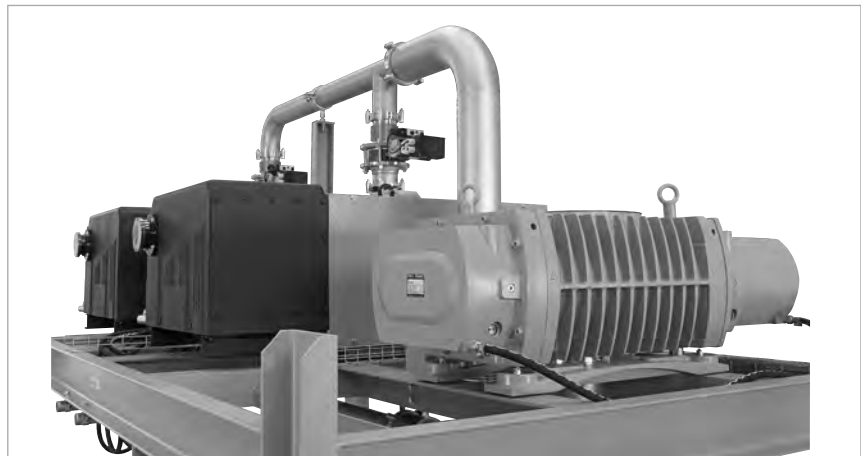

Pump system with WH 7000 Roots vacuum pump and SOGEVAC SV 630 B rotary vane vacuum pump

The use of Roots vacuum pumps in the area of vacuum technology has resulted in further specializations and improvements:

- Through an integrated bypass (pressure equalization line) it is also possible to utilize the pumping speed of the Roots vacuum pump at high pressures and large quantities of gas at an early stage. This reduces the pumpdown time especially for cyclic operation (see figure "Comparison of pumping speed characteristics with and without pressure equalization line").
- High-purity gases or hazardous gases impose strict requirements on the leak-tightness of the system. Canned motors from the WS line or canned motors from the WH line are hermetically sealed. There are no

seals in contact with the atmosphere which might be subject to wear. This prevents leaks and failures due to oil leaks. A service life of over 20,000 hours without maintenance is quite common.

- Tolerances and the quality of the balancing combined with forced lubricated bearings and toothed gears permit high speeds and the use of frequency converters. Thus it is possible to attain a high pumping speed while the process is in progress and to reduce the speed when the process has been stopped or while changing the batch. This results in a lower consumption of energy and a longer service life with uncompromised reliability.

- Conversion from vertical to horizontal flow is easily implemented and can be performed at the place where the pump has been installed. Thus the pump can be adapted more closely to the operating conditions of your system.

Lately, a further characteristic is gaining prominence: Roots vacuum pumps are capable of compressing the media in the pump chamber without the presence of any further media. This mostly avoids interaction between different media in the pump itself and also in the connected vacuum chamber. Therefore

- the medium which is pumped is not contaminated with lubricants or sealants; complex accessories (exhaust filters, separators, etc.) are not needed;
- the lubricant in the side chambers is hardly affected, so that service life is not reduced;
- backstreaming of oil from the backing pump into the connected vacuum chamber is prevented.

These characteristics make the Roots vacuum pump attractive for almost all rough and medium vacuum applications.

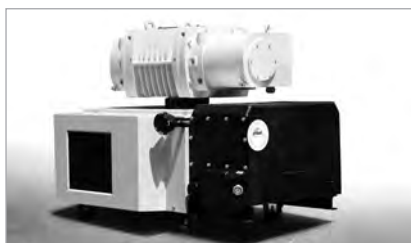

Pump system consisting of RUVAC WH 4400 and SOGEOVAC SV 630 B



Pump system with WH 7000 Roots vacuum pump and SOGEOVAC SV 630 B rotary vane vacuum pump

Semiconductor Technology (RUVAC WH and WS)

In the area of semiconductor technology, Roots vacuum pumps are found in etching processes among others, and in use with dry compressing backing pumps.

The pumping speed of the combination of backing pumps amounts to 200 to 500 m³/h (118 to 295 cfm) and it ensures a cut-in pressure of 10⁻¹ mbar (0.75 x 10⁻¹ Torr) for the turbomolecular pump. In the process, corrosive gases need to be pumped together with a high particle count.

Owing to the usage of media which present a health hazard, hermetically sealed pump versions are used. Due to the LVO 400 lubricant filling in the gear, a high degree of media resistance, long service intervals a high reliability and thus very low costs of ownership are attained.

For use in clean rooms, Roots vacuum pumps with a water cooled motor without a motor fan are used.

This type of motor reduces the quantity of heat dissipated to the surroundings to a minimum.

Central Vacuum Supply Systems

Large Roots vacuum pumps, usually in connection with single-stage rotary vane vacuum pumps serve several consumers of vacuum (packaging machines, for example) at the same time.

The pressure can be controlled in a highly flexible manner through the speed controller of the Roots pump, which allows for a flexible adaptation of the pumping speed. In the case of the RUVAC WH and WS types a significantly higher pumping speed can also be attained by means of a frequency converter compared to operation off the normal mains power.

Solar and Display

In the solar and display industry, Roots vacuum pumps can be found in almost all production steps. In connection with the Czochralski process or at DSS furnaces for the manufacture of silicon crystals, Roots vacuum pumps are deployed to rapidly attain the demanded conditioning pressure. In connection with the various coating processes they ensure the necessary pumping speed at process pressure and very fast cycles at the load lock chambers. In connection with lamination processes for the modules they assist in pumping down the laminators quickly and ensure a high pumping speed at lamination pressure.

Owing to the high production pressure, very much is demanded as to the reliability of the pumps during all process steps and this despite of reduced maintenance and service complexity.

Process Industry

Typical process industry applications are highly demanding regarding the ruggedness of Roots pumps. These need not only to pump clean media but must also be suited for pumping dusty or vapor containing media within an industrial environment.

Here a high level of ruggedness is demanded at a good price-to-performance ratio.

Whether during metallurgical processing or heat treatment of metals, in connection with drying processes, the plasma treatment of surfaces or in vacuum packaging processes – everywhere Roots pumps from the different RUVAC lines can excel. They permit a rapid pump down and offer a high pumping speed at process pressure. In combination with a frequency converter, extremely high pumping speeds are possible with a small footprint.

Operating Principle

Roots vacuum pumps, which are also called Roots blowers, are rotary plunger type pumps where two symmetrical shaped impellers rotate in opposite directions inside the pump housing.

The figure-of-eight rotors are synchronized by a gear which ensures that the impellers are counter-rotating in such a way, that they are near to one another and to the housing without actual contacting.

In rotor positions I and II (see figure “Operational diagram of a single-stage Roots vacuum pump (with vertical pumping action)”) the volume of the intake is increased. As the rotors turn further to position III a part of the volume is cut off from the intake side.

In position IV this volume is opened to the exhaust side and gas under fore-vacuum pressure (higher than the intake pressure) flows in. This gas compresses the gas coming from the intake. As the rotors turn further the compressed gas is ejected through the exhaust flange.

This process repeats itself twice for each rotor per full turn.

As the rotors do not come into contact with the pump's housing Roots vacuum pumps may be operated at high speeds. Thus a high pumping speed is obtained from comparably small pumps.

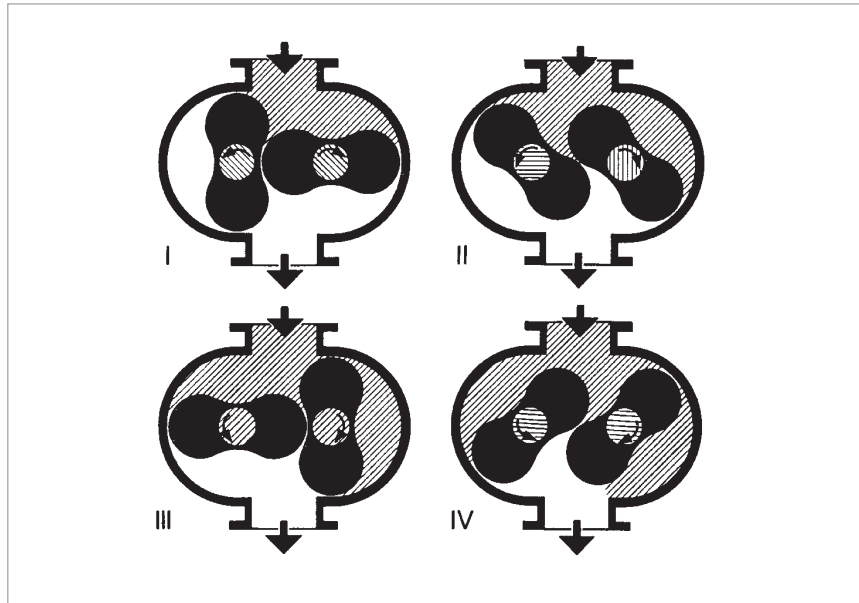

Operational diagram of a single-stage Roots vacuum pump (with vertical pumping action)

The pressure difference and the compression ratio between intake and exhaust is limited in Roots vacuum pumps.

In practice the maximum attainable pressure difference is of significance only in the rough vacuum range ($p > 10$ mbar ($p > 7.5$ Torr)) where-as in the medium vacuum range ($p < 1$ mbar ($p < 0.75$ Torr)) the attainable compression ratio is of importance.

Roots vacuum pumps from Leybold have been designed to specially meet the requirements of the fine vacuum range. They are normally used in connection with backing pumps or in closed gas cycles (WSLF series).

Design

The pump chamber of Roots vacuum pumps is free of any sealing agents or lubricants. Only the toothed wheels of the synchronous gear are lubricated with oil. Toothed gear wheels and bearings of the RUVAC are placed in two side chambers which also contain the oil reservoir. These two side chambers are separated from the pump chamber by piston ring seals.

Suitably designed oil supply systems in both chambers ensure that a sufficient quantity of oil is supplied to the gear wheels and bearings at all permissible speeds.

Almost all RUVAC Roots vacuum pumps are designed for a horizontal and vertical pumping action.

Types

Various types of Roots vacuum pumps have been developed to ensure optimum adaptation to the widely varying applications for this type of pump.

- **Flange mounted motor**
The drive shaft of the pump is directly connected to an electric motor via a flexible coupling. The required seal of the drive shaft against atmospheric pressure is obtained by oiled shaft seals.
- **Canned motor**
In the canned motor, rotor and stator pack are separated by a vacuum-tight can made of a non-magnetic material. The rotor operates on the drive shaft of the pump in the vacuum, so that a shaft seal which would be subject to wear is not required.
- **Hermetically sealed motor**
The hermetically sealed motor is the latest technology step for Roots vacuum pumps. It integrates the complete motor assembly into the vacuum reaching the same efficiency as a standard flange mounted motor without the need of a shaft seal. The hermetically sealed motor is the most compact, efficient and reliable motor technology available for roots pumps.
- **Pressure equalization line**
The integrated pressure equalization line connects the exhaust flange to the intake flange by means of a differential pressure valve. In the event of an excessively high pressure difference between the flanges, the valve will open. Then a part of the pumped gas will flow through this line back to the intake flange. Therefore the pump may be switched on together with the backing pump at atmospheric pressure. This increases the pumping speed of the pump combination also at high intake pressures.

- **Special ACE vibration absorber**
These pumps are best used in applications involving frequent pump-down cycles. The vibration absorber is of an oil sealed or filled design where minute amounts of oil may enter the vacuum system via the piston of the vibration attenuator.

RUVAC WA/WAU, WS/WSU

The series WA/WAU Roots vacuum pumps are provided with directly flange-mounted air-cooled standard three-phase motors. The oiled radial sealing rings of the RUVAC WA/WAU for sealing the shaft against the atmosphere are made of FPM (FKM) (fluoropolymer).

The WS/WSU series pumps have a air-cooled hermetically canned motor.

Roots vacuum pumps of the series WAU/WSU/WHU are provided with an additional integrated pressure equalization line and a differential pressure valve.

Pumps from these series are supplied with a vertical pumping action as standard.

RUVAC WH/WHU

The series WH/WHU pumps are technological leaders in the area of Roots vacuum pumps.

Both motors and oil reservoirs are water cooled thereby perfectly balancing the internal temperature management of the pumps resulting in significantly lower oil temperatures and thus a longer oil service life. At ultimate pressure, emissions are reduced by approximately 50% and the motor coils can sustain higher loads while at the same time offering improved efficiency. The new drive concept with potted motors replaces the can for hermetically sealed drives. This improves efficiency even further whereby the motors are capable of complying with the IE2 requirements of the new efficiency standard without problems.

In order to increase pumping speed thereby cutting pumpdown times, optionally available specially parameterized frequency converters can be used. Moreover, the pump may be operated at its maximum power already at atmospheric pressure.

Especially for short cycles the new WHU pump is being equipped with improved valve technology. Due to the bypass line, this pump can be operated starting at atmospheric pressure. The bypass valve already closes at a very early stage, whereby the cycle times can be significantly reduced. Pumps from the WHU series should not be operated over longer periods of time at high pressures.

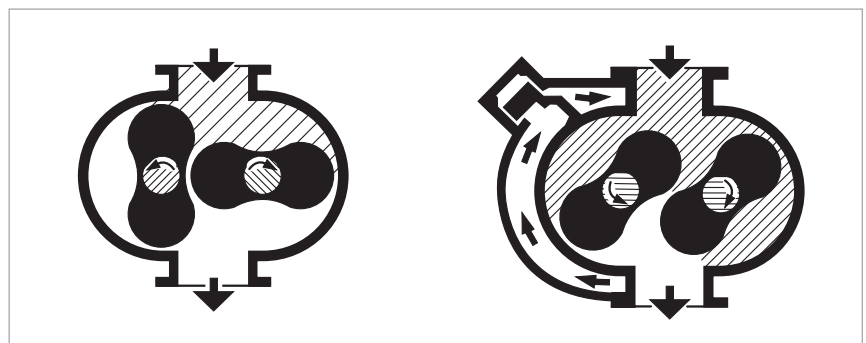

Schematic section through a RUVAC WA/WS (left) and a RUVAC WAU/WSU (right)

Using the RUVAC WS and RUVAC WH in combination with a frequency converter

Simulation of a pressure equalization line

The available frequency converters have been matched to the pump so that the possibility of mechanically overloading it is excluded. In the case of a pressure difference which is too high, the rotational speed of the pump is automatically reduced until its load drops in to the permissible range.

Operation at any rotational speeds

The frequency converter can be used to adjust the pumping speed of the Roots pump during operation. This allows maximum flexibility to find the right setup for any application.

Increasing the pumping speed

The pumps were developed to handle a maximum rotational speed between 4200 rpm and 7200 rpm depending on the respective pump size.

Therefore the use of a frequency converter permits an increase in the nominal pumping speed of up to 140%.

Note

Please enquire about possibly existing usage limits (process dependent).

Backing Pumps

The backing pumps from Leybold listed in the following are recommended for connection to the RUVAC Roots vacuum pumps:

- Rotary vane vacuum pumps
 - TRIVAC B with pumping speeds between 16 and 65 m³/h (9.4 and 38.3 cfm)
- Rotary vane vacuum pumps
 - SOGEVAC with pumping speeds between 16 and 1200 m³/h (9.4 and 707 cfm)
- Dry compressing screw vacuum pumps
 - SCREWLINE SP 250 and SP 630 with pumping speed of 250 and 630 m³/h (147.3 and 371 cfm)
- Dry compressing screw vacuum pumps
 - DRYVAC with pumping speed of 450 to 3800 m³/h (265 and 2238 cfm)
 - directly adaptable
 - smallest system
 - smart control



Pump system with Roots vacuum pumps and dry compressing vacuum pumps DRYVAC

Accessories

Frequency Converter V1000

A frequency converter was specially developed for the WH series which perfectly matches the requirements of vacuum engineering applications.

Owing to the flexible current limiting, the maximum pumping speed is available within the high pressure range whereas in the lower pressure ranges the current limit is reduced correspondingly so as to best protect the pump against thermal overloads.

This combination of power and protection can only be attained through our specially developed frequency converter.

“Plug and play operation” allows for simple installation. The frequency converters are set up in the factory so that they only need to be connected for optimised pump operation. It is not necessary to set up any additional parameters, and no further expert know-how is required.

DRYVAC backing pumps work also with the V1000.

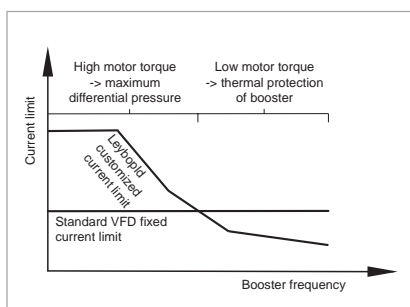

Flexible motor current limit V 1000

Frequency Converter RUVATRONIC RT 5

The electronic frequency converters RUVATRONIC RT 5/251 to 5/16000 have been designed specially for use in connection with Leybold Roots pumps of the RUVAC WA and WS series.

The main characteristics of the RUVATRONIC RT 5 are:

Simulation of a pressure equalization line

The software of the frequency converters is adapted to each pump and ensures that the risk of mechanically overloading the pump can be excluded. In the case of too high pressure differences, the rotational speed will be decreased automatically until the load is reduced to within the pump's limits. RUVAC Roots vacuum pumps of the types WA and WS (without pressure equalization line) can be switched on together with the forepump at atmospheric pressure. Through this, the pumpdown time can be reduced drastically. The minimum pumping speed of the backing pump needs to be considered in this case.

In connection with this kind of operation, the minimum pumping speed of the backing pump needs to be observed.

Pump	Required pumping speed for the backing pump
WA/WS 251	50 m ³ /h (29 cfm)
WA/WS 501	100 m ³ /h (59 cfm)
WA/WS 1001	200 m ³ /h (118 cfm)
WA/WS 2001	410 m ³ /h (241 cfm)
WH 700	140 m ³ /h (82 cfm)
WH/WHU 2500	430 m ³ /h (253 cfm)
WH/WHU 4400	880 m ³ /h (518 cfm)
WH/WHU 7000	1200 m ³ /h (707 cfm)

Operation at up to 3 predefined speeds

Via floating contacts, the pump can be operated at one of the 3 predefined speeds. Switching over to another predefined speed is possible during operation.

Operation at any rotational speed

With a 0 to 10 V signal, any speed can be predefined to operate the pump between the minimum and maximum rotational speed. The software reliably ensures that the rotational speed cannot drop below the minimum speed or exceed the maximum speed.

Increase in the pumping speed

By operating the Roots vacuum pumps at frequencies over 50 Hz, the nominal pumping speed of the pumps can be increased. Depending on the type of pump, an increase between 20 and 100% is possible.

Note

Please enquire about possible application limitations (process dependent).

Dust Separators and Dust Filters

Vacuum processes with a high particle count or involving significant quantities of dust require special measures for protecting the vacuum pumps.

Dust separators and dust filters can be found in the Catalog Part “Vacuum Pump Systems”, Chapter “Accessories for oil sealed and dry compressing vacuum pumps”.

Products

RUVAC WA/WAU 251 to 2001 Roots Vacuum Pumps with Air-Cooled Flange-Mounted Motors

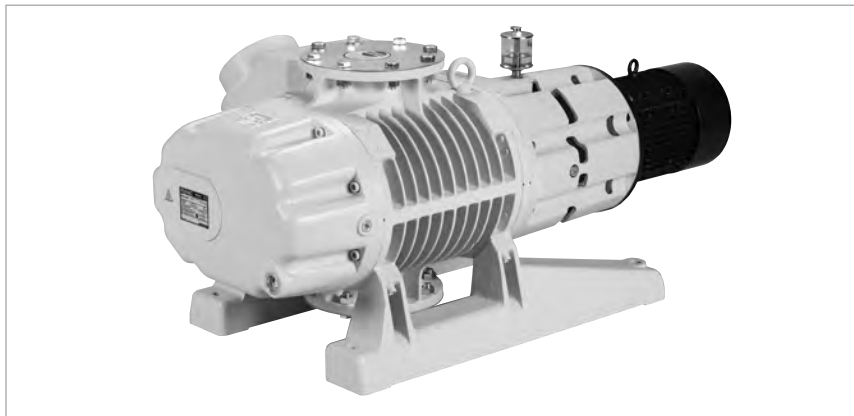

RUVAC WAU 2001 single-stage Roots vacuum pump

Advantages to the User

- Two air-cooled lines WA/WAU, each with four pump sizes
- Motors of efficiency class IE 3
- Reliable and trouble-free
- Sealing rings with their housing can be readily replaced
- Shaft seals and elastomer seals made of FPM (FKM)/Viton
- Easy to exchange with custom motors
- Integrated pressure equalization line for protection against overloading at high pressures on WAU models
- Conversion from vertical to horizontal pumping action can be done from the side of the customer
- All WA(U) pumps comply as standard with ATEX Cat. 3i (valid only for 50 Hz operation)
- Depending on requirements, motors from different ATEX categories can be fitted

Typical Applications

- For oil-free compression of gases and vapors in combination with a backing pump
- Short cycle pumping processes also in the presence of large quantities of gas and vapor

Supplied Equipment

- RUVAC WA/WAU are supplied as standard for a vertical pumping action, horizontal pumping action upon request
- Mineral oil LVO 100 is used as standard
- Gasket in the intake flange with dirt sieve
- The required lubricant filling is included in separate bottles

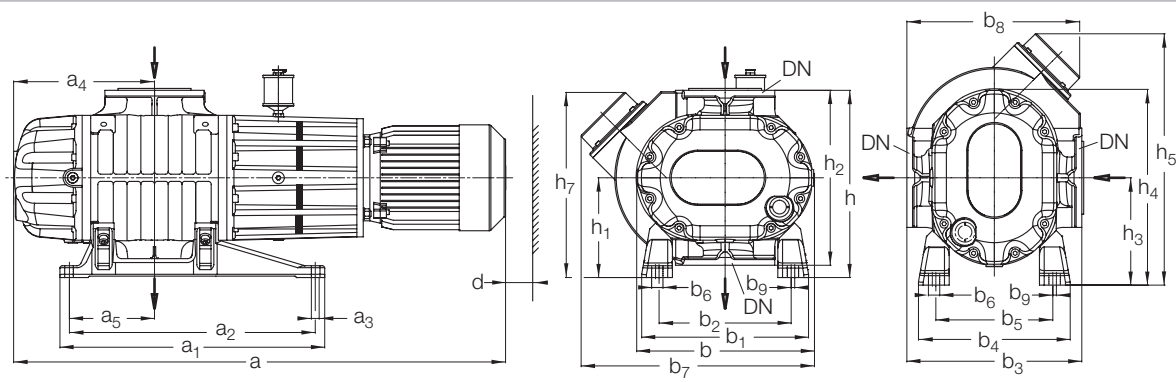

Type		DN	a ¹⁾	a ₁	a ₂	a ₃	a ₄	a ₅	a ₆	b
WA/WAU 251	mm	63	732	405	365	14	209	120	194	250
	in.		28.82	15.94	14.37	0.55	8.23	4.72	7.64	9.84
WA/WAU 501	mm	63	830	486	450	14	237	155	218	310
	in.		32.68	19.13	17.72	0.55	9.33	6.10	8.58	12.20
WA/WAU 501H	mm	63	830	486	450	14	237	155	218	310
	in.		32.88	19.13	17.72	0.55	9.33	6.10	8.58	12.20
WA/WAU 1001	mm	100	1054	560	520	16.5	298	180	262	376
	in.		41.50	22.05	20.47	0.65	11.73	6.10	10.31	14.80
WA/WAU 1001H	mm	100	1054	560	520	16.5	298	180	262	376
	in.		41.50	22.05	20.47	0.65	11.73	6.10	10.31	14.80
WA/WAU 2001	mm	160	1275	800	740	18	367	220	310	463
	in.		50.20	31.50	29.13	0.71	14.45	8.66	12.20	18.23
WA/WAU 2001H	mm	160	1275	800	740	18	367	220	310	463
	in.		50.20	31.50	29.13	0.71	14.45	8.66	12.20	18.23

		b ₁	b ₂	b ₃	b ₄	b ₅	b ₆	b ₇ ²⁾	b ₈	b ₉	d
WA/WAU 251	mm	270	210	280	230	170	24	305	285	7.5	50
	in.	10.63	8.27	11.02	9.06	6.69	0.94	12.01	11.22	0.30	2.00
WA/WAU 501	mm	299	229	320	271	201	24	390	313	7.5	50
	in.	11.77	9.02	12.60	10.67	7.91	0.94	15.35	12.32	0.30	2.00
WA/WAU 501H	mm	299	229	320	271	201	24	414	330	7.5	50
	in.	11.77	9.02	12.60	10.67	7.91	0.94	16.30	12.99	0.30	2.00
WA/WAU 1001	mm	352	278	370	320	246	24	494	366	7.5	50
	in.	13.86	10.94	14.57	12.60	7.91	0.94	19.45	14.41	0.30	2.00
WA/WAU 1001H	mm	352	278	370	320	246	24	524	398	7.5	50
	in.	13.86	10.94	14.57	12.60	7.91	0.94	20.63	15.67	0.30	2.00
WA/WAU 2001	mm	518	388	460	422	292	24	638	456	7.5	50
	in.	20.39	15.28	18.11	16.61	11.50	0.94	25.12	17.95	0.30	2.00
WA/WAU 2001H	mm	518	388	460	422	292	24	642	460	7.5	50
	in.	20.39	15.28	18.11	16.61	11.50	0.94	25.28	18.11	0.30	2.00

		h	h ₁	h ₂	h ₃	h ₄	h ₅ ²⁾	h ₆	h ₇
WA/WAU 251	mm	300	160	280	180	306	360	330	307
	in.	11.81	6.30	11.02	7.09	12.05	14.17	12.99	12.09
WA/WAU 501	mm	340	180	320	194	348	430	370	332
	in.	13.39	7.09	12.60	7.48	13.70	16.93	14.57	13.07
WA/WAU 501H	mm	340	180	320	194	348	450	370	350
	in.	13.39	7.09	12.60	7.48	13.70	17.72	14.57	13.78
WA/WAU 1001	mm	396	211	370	227	414	532	425	392
	in.	15.59	8.31	14.57	8.94	16.30	20.94	425	15.43
WA/WAU 1001H	mm	396	211	370	227	414	564	425	424
	in.	15.59	8.31	14.57	8.94	16.30	22.20	425	16.69
WA/WAU 2001	mm	530	300	460	351	578	753	541	523
	in.	20.87	11.81	18.11	13.82	22.76	29.65	21.3	20.59
WA/WAU 2001H	mm	530	300	460	351	578	760	541	530
	in.	20.87	11.81	18.11	13.82	22.76	29.92	21.3	20.87

¹⁾ This dimension "a" relates to pumps with the IEC motor used as standard by Leybold
²⁾ For RUVAC WAU only

DN = PN 6 pump flange in accordance with DIN 2501
 Outside dimensions ±3 mm (0.12 in.)

Dimensional drawing for the RUVAC WA/WAU(H) pumps

Technical Data

WA/WAU 251

WA/WAU(H) 501

		50 Hz	60 Hz	50 Hz	60 Hz
Nominal pumping speed ¹⁾	m ³ /h (cfm)	253.0 (149.0)	304.0 (179.0)	505.0 (297.4)	606.0 (357.0)
Max. effective pumping speed with backing pump	m ³ /h (cfm)	210.0 (123.7)	251.0 (148.0)	410.0 (241.0)	530.0 (312.0)
	TRIVAC SOGEVAC	D 65 B –	D 65 B –	– SV 200	– SV 200
Ultimate total pressure ²⁾	mbar (Torr)	< 8 x 10 ⁻⁴ (< 6 x 10 ⁻⁴)	< 8 x 10 ⁻⁴ (< 6 x 10 ⁻⁴)	< 4 x 10 ⁻² (< 3 x 10 ⁻²)	< 4 x 10 ⁻² (< 3 x 10 ⁻²)
Max. permissible pressure difference during continuous operation ³⁾	mbar (Torr)	80 (60.0)			
Leak rate, integral	mbar x l/s	< 5 x 10 ⁻⁴			
Mains supply	V	200–240			
	V	380–400			
Thermal class		F			
Permissible ambient temperatures	°C (°F)	+5 to +40 (+ 41 to +104)			
Motor power	kW (hp)	1.1 (1.5)	1.1 (1.5)	2.2 (3.0)	2.2 (3.0)
Energy efficiency class		IE 3			
Nominal speed, approx.	rpm	3000	3600	3000	3600
Max. permissible speed	rpm	3600			
Type of protection	IP	55			
ATEX protection category ⁴⁾		Category 3i	–	Category 3i	–
Lubricant for the bearing chamber ⁵⁾	vertical pumping action, approx.	0.6 (0.63)	0.6 (0.63)	0.8 (0.85)	0.8 (0.85)
	horizontal pumping action, approx.	0.45 (0.48)	0.45 (0.48)	0.7 (0.74)	0.7 (0.74)
Lubricant of the shaft sealing ring housing	l (qt)	0.6 (0.63)	0.6 (0.63)	1.0 (1.06)	1.0 (1.06)
Connection flanges	DN	63 ISO-K			
Materials (materials in contact with the gas)		C steel, CrNi steel, grey cast iron, FPM (FKM)			
Weight WA / WAU	kg (lbs)	85.0 / 89.0 (187.4 / 196.2)	85.0 / 89.0 (187.4 / 196.2)	128.0 / 133.0 (187.4 / 196.2)	128.0 / 133.0 (187.4 / 196.2)
Noise level ⁶⁾	dB(A)	< 62	< 64	< 65	< 67

¹⁾ To DIN 28 400 and subsequent numbers

²⁾ With double-stage rotary vane vacuum pump TRIVAC, resp. single-stage rotary vane vacuum pump SOGEVAC (Type of backing pump look at max. pumping speed).

When using 2-stage backing pumps the ultimate pressures will be correspondingly lower

³⁾ Applicable for ratio up to 1 : 10 between backing pump and Roots vacuum pump at 3000 rpm

⁴⁾ For ATEX category 3o a appropriate motor has to be used.

Please contact Leybold (System)

⁵⁾ Authoritative, however, is the oil level at the oil-level glass

⁶⁾ Valid under ultimate pressure conditions. Pressures over 10 mbar (7.5 Torr) produce a higher operating noise

Technical Data

		WA/WAU (H) 1001		WA/WAU(H) 2001	
		50 Hz	60 Hz	50 Hz	60 Hz
Nominal pumping speed ¹⁾	m ³ /h (cfm)	1000 (589)	1200 (707)	2050 (1207.5)	2460 (1449)
Max. effective pumping speed with backing pump	m ³ /h (cfm) SOGEVAC	800 (470) SV 300 B	1000 (588) SV 300 B	1850 (1089) SV 630 BF	2100 (1236) SV 630 BF
Ultimate total pressure ²⁾	mbar (Torr)	< 4 x 10 ⁻² (< 3 x 10 ⁻²)			
Max. permissible pressure difference during continuous operation ³⁾	mbar (Torr)	80.0 (60.0)	80.0 (60.0)	50.0 (37.5)	50.0 (37.5)
Leak rate, integral	mbar x l/s	< 5 · 10 ⁻⁴			
Mains supply	V V	200–240 380–400			
Thermal class		F			
Permissible ambient temperatures	°C (°F)	+5 to +40 (+ 41 to +104)			
Motor power	kW (hp)	4.0 (5.4)	4.0 (5.4)	7.5 (10.0)	7.5 (10.0)
Energy efficiency class		IE 3			
Nominal speed, approx.	rpm	3000	3600	3000	3600
Max. zulässige Drehzahl	rpm	3600			
Type of protection	IP	55			
ATEX protection category ⁴⁾		Category 3i	–	Category 3i	–
Lubricant for the bearing chamber ⁵⁾					
vertical pumping action, approx.	l (qt)	1.8 (1.90)	1.8 (1.90)	3.6 (3.81)	3.6 (3.81)
horizontal pumping action, approx.	l (qt)	1.1 (1.16)	1.1 (1.16)	2.4 (2.54)	2.4 (2.54)
Lubricant of the shaft sealing ring housing	l (qt)	1.3 (1.37)	1.3 (1.37)	1.6 (1.69)	1.6 (1.69)
Connection flanges	DN	100 ISO-K	100 ISO-K	160 ISO-K	160 ISO-K
Materials (materials in contact with the gas)		C-Stahl, CrNi-Stahl, Grauguss, FPM			
Weight WA / WAU	kg (lbs)	220 / 225 (485.1 / 496.1)	220 / 225 (485.1 / 496.1)	400 / 406 (882.0 / 895.2)	400 / 406 (882.0 / 895.2)
Noise level ⁶⁾	dB(A)	< 70	< 73	< 72	< 77

¹⁾ To DIN 28 400 and subsequent numbers

²⁾ With single-stage rotary vane vacuum pump SOGEVAC (Type of backing pump look at max. pumping speed).
When using 2-stage backing pumps the ultimate pressures will be correspondingly lower

³⁾ Applicable for ratio up to 1 : 10 between backing pump and Roots vacuum pump at 3000 rpm

⁴⁾ For ATEX category 3o a appropriate motor has to be used.
Please contact Leybold (System)

⁵⁾ Authoritative, however, is the oil level at the oil-level glass

⁶⁾ Valid under ultimate pressure conditions. Pressures over 10 mbar (7.5 Torr) produce a higher operating noise

Ordering Information

	WA/WAU	WA/WAU(H)	WA/WAU(H)	WA/WAU(H)
	251	501	1001	2001
	Part No.	Part No.	Part No.	Part No.
Roots vacuum pump				
RUVAC WA	117 20	117 30	117 40	117 50
RUVAC WAU	117 21	117 31	117 41	117 51
RUVAC WA, without motor	117 24	117 34	117 44	112 54
RUVAC WAU, without motor	155 011V	155 008	112 17	113 22
RUVAC WAU(H), with special ACE vibration absorber	-	118 31	118 41	118 51
Mandatory Accessories				
Collar flange with retaining ring, DIN 2501 ¹⁾				
DN 63 ISO-K	86747V01	86747V01	-	-
DN 100 ISO-K	-	-	86750V01	-
DN 160 ISO-K	-	-	-	86751V01
Accessories				
RUVAC WS/WSU(H) seal kit	194 60	194 64	194 68	194 72
Flange adapter set, consisting of Flange adapter with screws, bolts, washers and nuts for ANSI flange	(3" ANSI)	(3" ANSI)	(4" ANSI)	(6" ANSI)
WA/WS pump	200 03 179V	200 03 179V	200 03 180V	200 03 181V
WAU/WSU pump	200 03 179V	200 03 179V	200 03 180V	200 03 182V
RUVAC WA US conversion kit, consisting of ANSI flanges 3 in., NEMA motor flange, coupling and installation components WA(U) pumps	155 013V	155 014V	155 015V	155 016V
Frequency converter RUVATRONIC (see description in chapter "General", paragraph "Accessories")	RT 5/251 500 001 381	RT 5/501 500 001 382	RT 5/1001 500 001 383	RT 5/2001 500 001 384
Accessories				
Shaft sealing ring replacement kit WA/WAU	EK 110 002 661	EK 110 002 661	EK 110 002 662	EK 110 002 662
Major maintenance kit				
WA	EK 110 002 663	EK 110 002 664	EK 110 002 667	EK 110 002 669
WAU	EK 110 002 665	EK 110 002 666	EK 110 002 668	EK 110 002 670

¹⁾ For connection to flange system DN 63 ISO-K, resp. DN 100 ISO-K, resp. DN 160 ISO-K

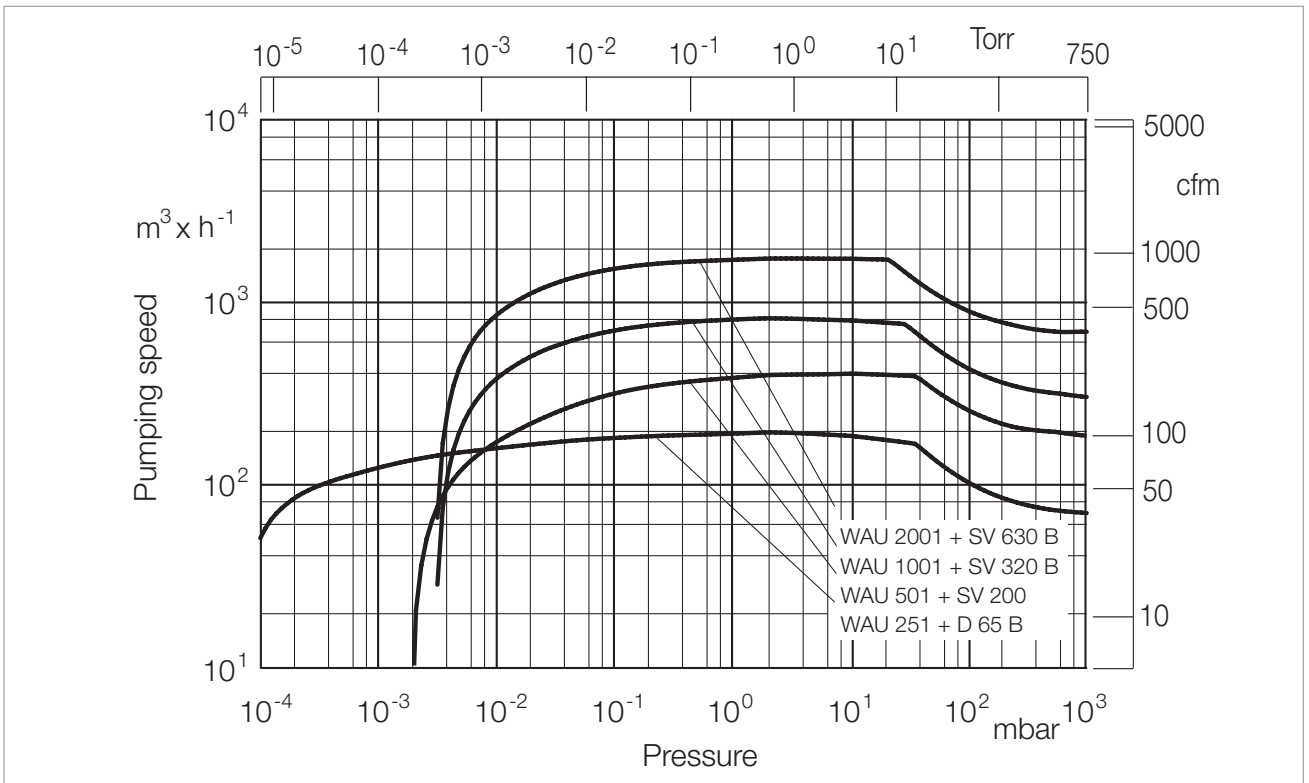

Pumping speed of the RUVAC WA/WAU, 50 Hz

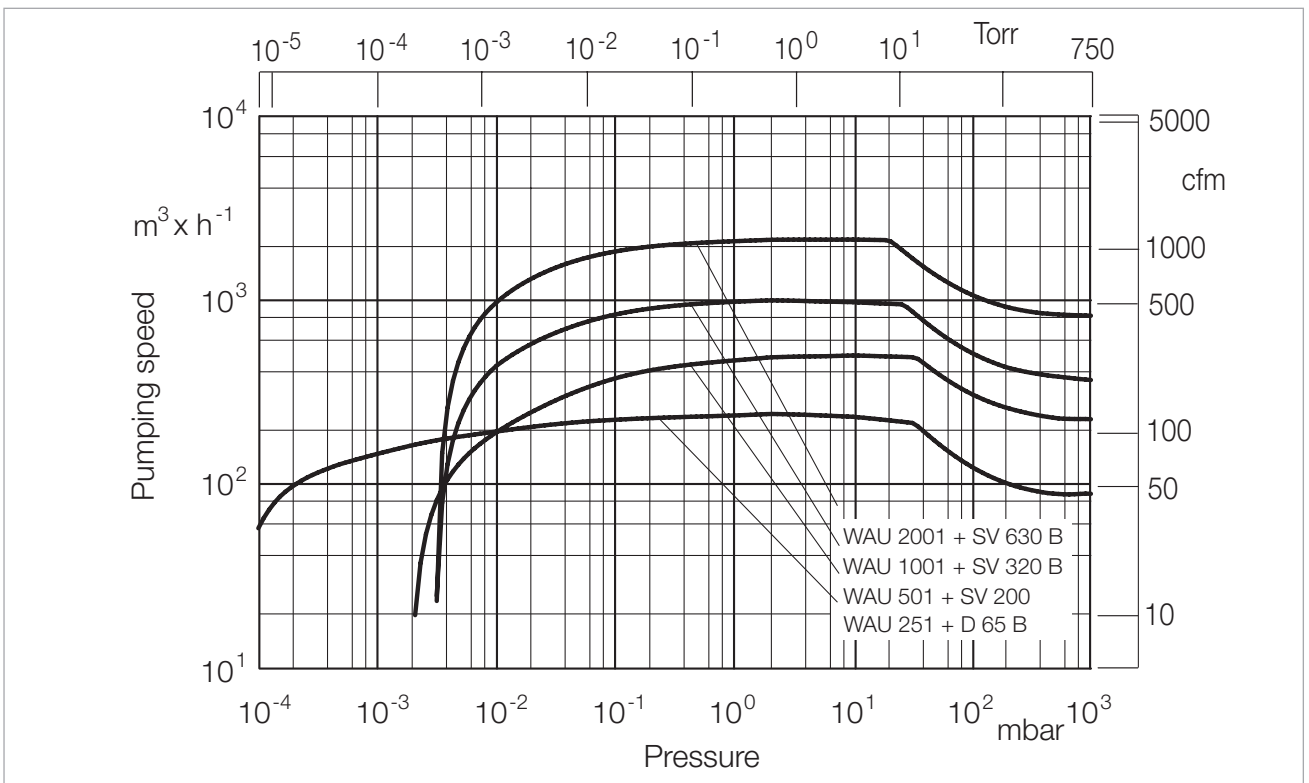

Pumping speed of the RUVAC WA/WAU, 60 Hz

RUVAC WS/WSU 251 to 2001 Roots Vacuum Pumps with Air-Cooled Canned Motors

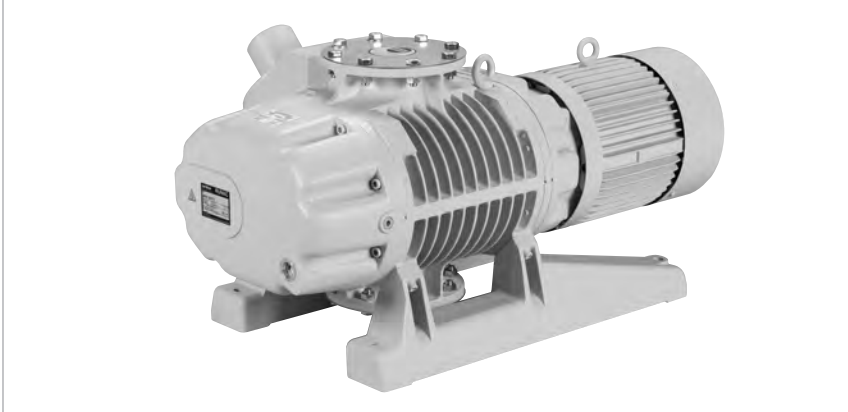

Single-stage Roots vacuum pump RUVAC WSU 2001

Advantages to the User

- Two air-cooled lines WS/WSU, each with four pump sizes
- Highly leak-tight air-cooled pumps driven by a air-cooled canned motor
- Lubricated with mineral oil (alternatively with LVO 400)
- Over-temperature switch in the stator coil of the motor
- All elastomer seals made of FPM (FKM)/Viton
- Integrated pressure equalization line with differential pressure valve prevents overloading on WSU model (optional)
- A frequency converter can be used to operate the RUVAC WS 251 to 2001 pumps between 20 and 100 Hz
- No shaft feedthrough to the atmosphere, thus particularly leak-tight
- Conversion from vertical to horizontal pumping action can be done from the side of the customer

Typical Applications

- For applications which require a high pumping speed at pressures between 10^{-2} and 10^{-4} mbar (0.75×10^{-2} and 0.75×10^{-4} Torr)
- Used where the possibility of contamination due air ingress or pumped media leakage must be avoided
- Suction or pumping of high-purity gases
- Is used in clean rooms where the air must not be recirculated by the motor's fan

Supplied Equipment

- The required quantity of oil is supplied separately with the pump (exceptions from this are indicated)
- If no other type of oil is stated, then mineral oil LVO 100 is used as standard
- Purged with nitrogen for corrosion protection
- Gasket in the intake flange with integrated dirt sieve

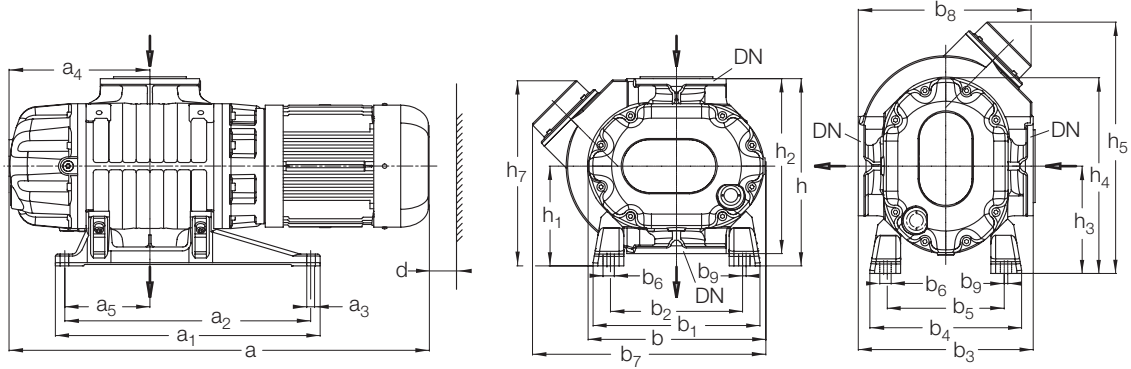

Type		DN	a	a ₁	a ₂	a ₃	a ₄	a ₅
WS/WSU 251	mm	63	694	405	365	14	212	120
	in.		27.32	15.94	14.37	0.55	8.35	4.72
WS/WSU 501	mm	63	752	486	450	14	237	155
	in.		29.61	19.13	17.72	0.55	9.33	6.10
WS/WSU 501H	mm	63	752	486	450	14	237	155
	in.		29.61	19.13	17.72	0.55	9.33	6.10
WS/WSU 1001	mm	100	885	560	520	16,5	298	180
	in.		34.84	22.05	20.47	0.65	11.73	7.09
WS/WSU 1001H	mm	100	885	560	520	16,5	298	180
	in.		34.84	22.05	20.47	0.65	11.73	7.09
WS/WSU 2001	mm	160	1042	800	740	18	367	220
	in.		41.02	31.50	29.13	0.71	14.45	8.66
WS/WSU 2001H	mm	160	1042	800	740	18	367	220
	in.		41.02	31.50	29.13	0.71	14.45	8.66

		b	b ₁	b ₂	b ₃	b ₄	b ₅	b ₆	b ₇ ¹⁾	b ₈
WS/WSU 251	mm	250	270	210	280	230	170	24	305	285
	in.	9.84	10.63	8.27	11.02	9.06	6.69	0.94	12.01	11.22
WS/WSU 501	mm	310	299	229	320	271	201	24	390	313
	in.	12.20	11.77	9.02	12.60	10.67	7.91	0.94	15.35	12.32
WS/WSU 501H	mm	310	299	229	320	271	201	24	414	330
	in.	12.20	11.77	9.02	12.60	10.67	7.91	0.94	16.30	12.99
WS/WSU 1001	mm	376	352	278	370	320	246	24	494	366
	in.	14.80	13.86	10.94	14.57	12.60	9.69	0.94	19.45	14.41
WS/WSU 1001H	mm	376	352	278	370	320	246	24	524	398
	in.	14.80	13.86	10.94	14.57	12.60	9.69	0.94	20.63	15.67
WS/WSU 2001	mm	463	518	388	460	422	292	24	638	456
	in.	18.23	20.39	15.28	18.11	16.61	11.50	0.94	25.12	17.95
WS/WSU 2001H	mm	463	518	388	460	422	292	24	642	460
	in.	18.23	20.39	15.28	18.11	16.61	11.50	0.94	25.28	18.11

		b ₉	d	h	h ₁	h ₂	h ₃	h ₄	h ₅ ¹⁾	h ₆
WS/WSU 251	mm	7.5	50	300	160	280	180	306	360	307
	in.	0.30	2.00	11.81	6.3	11.02	7.09	12.05	14.17	12.09
WS/WSU 501	mm	7.5	50	340	180	320	194	348	430	332
	in.	0.30	2.00	13.39	7.09	12.60	7.48	13.70	16.93	13.07
WS/WSU 501H	mm	7.5	50	340	180	320	194	348	450	350
	in.	0.30	2.00	13.39	7.09	12.60	7.48	13.70	17.72	13.78
WS/WSU 1001	mm	7.5	50	396	211	370	227	414	532	392
	in.	0.30	2.00	15.59	8.31	14.57	8.94	16.30	20.94	15.43
WS/WSU 1001H	mm	7.5	50	396	211	370	227	414	564	424
	in.	0.30	2.00	15.59	8.31	14.57	8.94	16.30	22.20	16.69
WS/WSU 2001	mm	7.5	50	530	300	460	351	578	760	523
	in.	0.30	2.00	20.87	11.81	18.11	13.82	22.76	29.92	20.59
WS/WSU 2001H	mm	7.5	50	530	300	460	351	578	753	530
	in.	0.30	2.00	20.87	11.81	18.11	13.82	22.76	29.65	20.87

¹⁾ For RUVAC WSU only
Outside dimensions ±3 mm (0.12 in.)

DN₁ = PN 6 pump flange in accordance with DIN 2501

Dimensional drawing for the RUVAC WS/WSU(H) pumps

Technical Data

WS/WSU 251

WS/WSU(H) 501

		50 Hz	60 Hz	50 Hz	60 Hz
Nominal pumping speed ¹⁾	m ³ /h (cfm)	253 (149)	304 (179)	505 (297.4)	606 (357)
Max. effective pumping speed with backing pump	m ³ /h (cfm)	210.0 (123.7)	251.0 (148.0)	410.0 (241.0)	530.0 (312.0)
	TRIVAC SOGEVAC	D 65 B –	D 65 B –	– SV 200	– SV 200
Ultimate total pressure ²⁾	mbar (Torr)	< 8 x 10 ⁻⁴ (< 6 x 10 ⁻⁴)	< 8 x 10 ⁻⁴ (< 6 x 10 ⁻⁴)	< 4 x 10 ⁻² (< 3 x 10 ⁻²)	< 4 x 10 ⁻² (< 3 x 10 ⁻²)
Max. permissible pressure difference during continuous operation ³⁾	mbar (Torr)	80.0 (60.0)			
Leak rate, integral	mbar x l/s	< 1 x 10 ⁻⁴			
Mains supply	V	200 / 230 / 400	200–208 / 265 / 460	200 / 230 / 400	200–208 / 265 / 460
Thermal class		F			
Permissible ambient temperatures	°C (°F)	+5 to +40 (+41 to +104)			
Motor power	kW (hp)	1.1 (1.5)	1.4 (1.9)	2.2 (3.0)	2.4 (3.3)
Nominal speed, approx.	rpm	3000	3600	3000	3600
Max. permissible speed	rpm	6000			
Type of protection	IP	20			
Lubricant for the bearing chamber ⁴⁾					
LVO 400					
vertical pumping action, approx.	l (qt)	0.55 (0.58)	0.55 (0.58)	0.75 (0.79)	0.75 (0.79)
horizontal pumping action, approx.	l (qt)	0.45 (0.48)	0.45 (0.48)	0.7 (0.74)	0.7 (0.74)
other oils					
vertical pumping action, approx.	l (qt)	0.6 (0.63)	0.6 (0.63)	0.8 (0.85)	0.8 (0.85)
horizontal pumping action, approx.	l (qt)	0.45 (0.48)	0.45 (0.48)	0.7 (0.74)	0.7 (0.74)
Connection flanges	DN	63 ISO-K			
Weight WS / WSU	kg (lbs)	90 / 95 (198.5 / 209.5)	90 / 95 (198.5 / 209.5)	130 / 135 (286.7 / 297.7)	130 / 135 (286.7 / 297.7)
Noise level ⁵⁾	dB(A)	< 58	< 60	< 52	< 56

¹⁾ To DIN 28 400 and subsequent numbers

²⁾ With double-stage rotary vane vacuum pump TRIVAC or single-stage rotary vane vacuum pump SOGEVAC (Type of backing pump look at max. pumping speed)

When using 2-stage backing pumps the ultimate pressures will be correspondingly lower

³⁾ Applicable for ratio up to 1 : 10 between backing pump and Roots vacuum pump at 3000 rpm

⁴⁾ Authoritative, however, is the oil level at the oil-level glass

⁵⁾ Valid under ultimate pressure conditions. Pressures over 10 mbar (7.5 Torr) produce a higher operating noise

Technical Data

		WS/WSU(H) 1001		WS/WSU(H) 2001	
		50 Hz	60 Hz	50 Hz	60 Hz
Nominal pumping speed ¹⁾	m ³ /h (cfm)	1000 (589)	1200 (707)	2050 (1207.5)	2460 (1449)
Max. effective pumping speed with backing pump	m ³ /h (cfm) SOGEVAC	800 (470) SV 300 B	1000 (588) SV 300 B	1850 (1089) SV 630 BF	2100 (1236) SV 630 BF
Ultimate total pressure ²⁾	mbar (Torr)	< 4 x 10 ⁻² (< 3 x 10 ⁻²)			
Max. permissible pressure difference during continuous operation ³⁾	mbar (Torr)	80.0 (60.0)	80.0 (60.0)	50.0 (37.5)	50.0 (37.5)
Leak rate, integral	mbar x l/s	< 1 x 10 ⁻⁴			
Mains supply	V	200 / 230 / 400	200–208 / 265 / 460	200 / 230 / 400	200–208 / 265 / 460
Thermal class		F			
Permissible ambient temperatures	°C (°F)	+5 to +40 (+41 to +104)			
Motor power	kW (hp)	4.0 (5.4)	4.4 (6.0)	7.5 (10.0)	8.5 (11.6)
Nominal speed, approx.	rpm	3000	3600	3000	3600
Max. permissible speed	rpm	6000	6000	4200 ⁴⁾	4200 ⁴⁾
Type of protection	IP	20			
Lubricant for the bearing chamber ⁵⁾					
LVO 400					
vertical pumping action, approx.	l (qt)	1.75 (1.85)	1.75 (1.85)	2.7 (2.85)	2.7 (2.85)
horizontal pumping action, approx.	l (qt)	1.1 (1.16)	1.1 (1.16)	1.9 (2.00)	1.9 (2.00)
other oils					
vertical pumping action, approx.	l (qt)	1.8 (1.90)	1.8 (1.90)	3.6 (3.81)	3.6 (3.81)
horizontal pumping action, approx.	l (qt)	1.1 (1.16)	1.1 (1.16)	2.4 (2.54)	2.4 (2.54)
Connection flanges	DN	100 ISO-K	100 ISO-K	160 ISO-K	160 ISO-K
Weight WS / WSU	kg (lbs)	228 / 233 (502.7 / 513.8)	228 / 233 (502.7 / 513.8)	458 / 465 (1009.9 / 1025.3)	458 / 465 (1009.9 / 1025.3)
Noise level ⁵⁾	dB(A)	< 60	< 60	< 65	< 67

¹⁾ To DIN 28 400 and subsequent numbers

²⁾ With single-stage rotary vane vacuum pump SOGEVAC
(Type of backing pump look at max. pumping speed)

When using 2-stage backing pumps the ultimate pressures will be correspondingly lower

³⁾ Applicable for ratio up to 1 : 10 between backing pump and Roots vacuum pump at 3000 rpm

⁴⁾ Also 6000 rpm upon order

⁵⁾ Authoritative, however, is the oil level at the oil-level glass

⁶⁾ Valid under ultimate pressure conditions. Pressures over 10 mbar (7.5 Torr) produce a higher operating noise

Ordering Information

	WS/WSU	WS/WSU(H)	WS/WSU(H)	WS/WSU(H)
	251	501	1001	2001
	Part No.	Part No.	Part No.	Part No.
Roots vacuum pump				
RUVAC WS, (LVO 100)	117 22	117 32	117 42	117 52
RUVAC WSU, (LVO 100)	117 23	117 33	117 43	117 53
RUVAC WS-PFPE oil, (LVO 400)	117 27	117 37	117 47	117 57
RUVAC WSU-PFPE oil, (LVO 400)	117 28	117 38	-	200 03 123
RUVAC WS 2001-Ester oil, (LVO 210) (max. 100 Hz)	-	-	-	167 007
RUVAC WS 2001-PFPE oil, (LVO 400) (max. 100 Hz)	-	-	-	150 95
RUVAC WSU 2001-Ester oil (LVO 210) (max. 100 Hz)	-	-	-	150 96
RUVAC WSU H, (LVO 100) with special ACE vibration absorber	-	118 33	118 43	118 53
RUVAC WSU H-PFPE oil, (LVO 400) with special ACE vibration absorber	-	-	150 47	167 129V
Mandatory Accessories				
Collar flange with retaining ring, DIN 2501 ¹⁾				
DN 63 ISO-K	86747V01	86747V01	-	-
DN 100 ISO-K	-	-	86750V01	-
DN 160 ISO-K	-	-	-	86751V01
Accessories				
Flange adapter set, consisting of flange adapter with screws, bolts, washers and nuts for ANSI flange	(3" ANSI)	(3" ANSI)	(4" ANSI)	(6" ANSI)
WA/WS pump	200 03 179V	200 03 179V	200 03 180V	200 03 181V
WAU/WSU pump	200 03 179V	200 03 179V	200 03 180V	200 03 182V
Frequency converter RUVATRONIC (see description in chapter "General", paragraph "Accessories")	RT 5/251	RT 5/501	RT 5/1001	RT 5/2001
	500 001 381	500 001 382	500 001 383	500 001 384
Spare Parts				
RUVAC WS/WSU(H) seal kit	194 62	194 66	194 70	194 74
Major maintenance kit				
WS	EK 110 002 671	EK 110 002 672	EK 110 002 673	EK 110 002 674
WSU	EK 110 002 675	EK 110 002 676	EK 110 002 677	EK 110 002 678

¹⁾ For connection to flange system DN 63 ISO-K, resp. DN 100 ISO-K, resp. DN 160 ISO-K

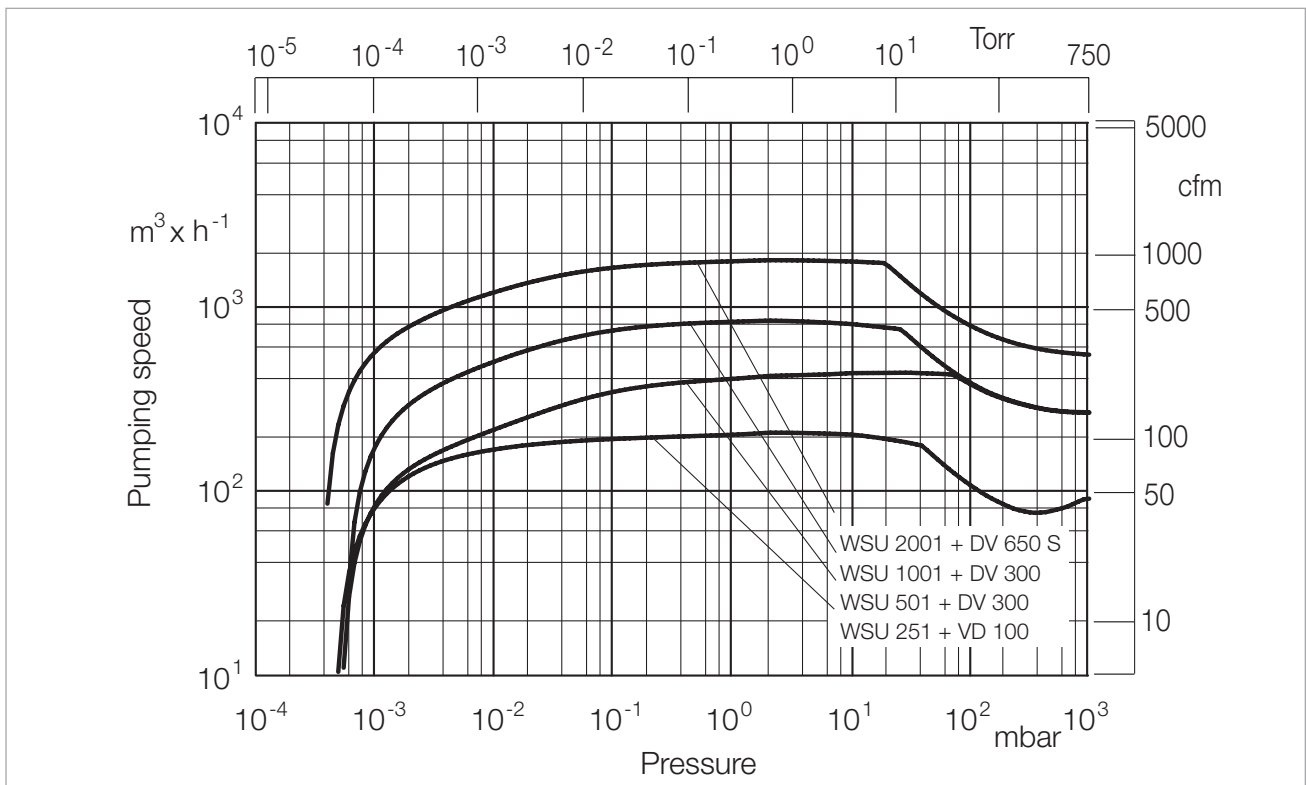

Pumping speed of the RUVAC WS/WSU, 50 Hz

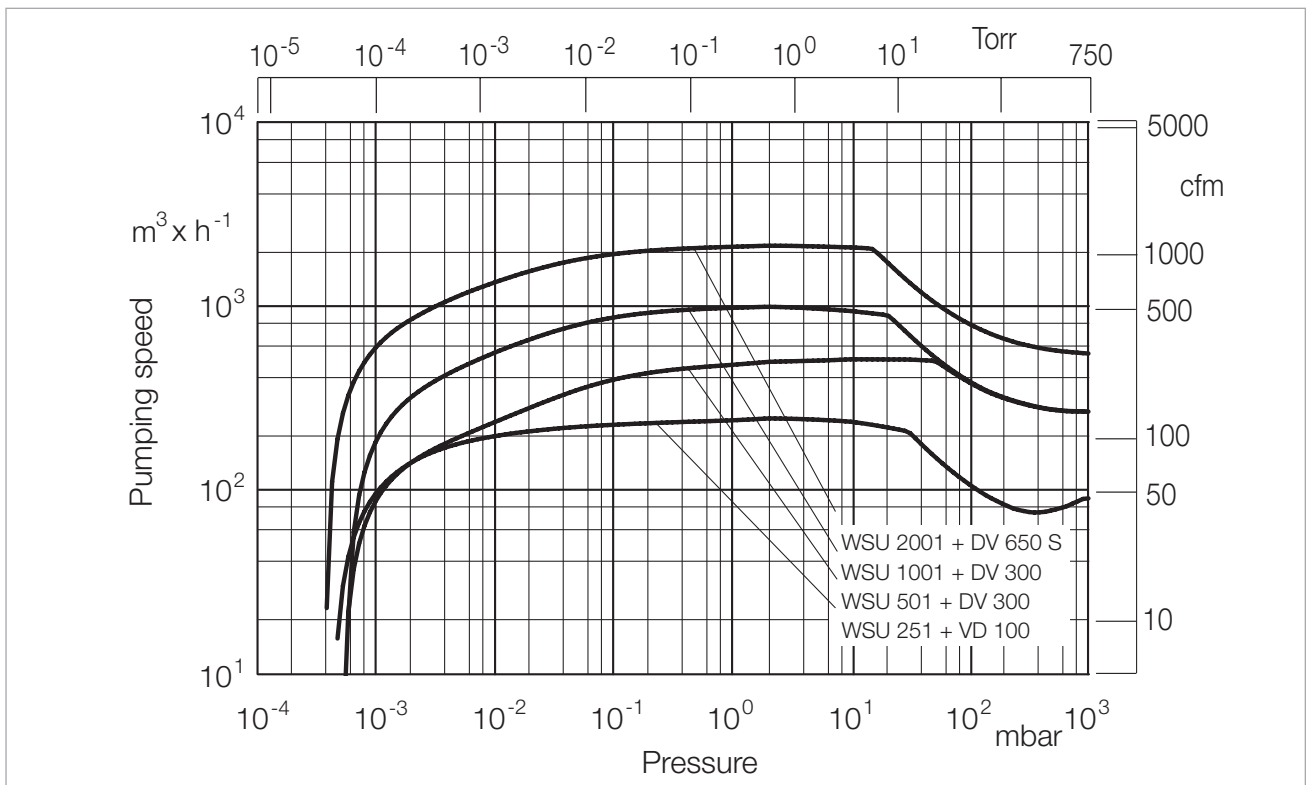

Pumping speed of the RUVAC WS/WSU, 60 Hz

RUVAC WH/WHU Roots Vacuum Pumps with Water-Cooled Hermetically Sealed Motors with Synthetic Oil or PFPE filling



RUVAC WH 4400 and WH 7000 single-stage Roots vacuum pump with hermetically sealed motor

Advantages to the User

- Lower energy costs through innovative motor technology (relates to efficiency class IE 2)
 - Minimized space requirements due to an extremely compact design
 - Easy system integration
 - Optimum price-to-performance ratio; high pumping speed up to 9800 m³/h @ 70 Hz with optional frequency converter
 - Integrated water cooling system for installation within closed systems
 - Parts in contact with the cooling water are made of stainless steel (corrosion-free)
 - Trouble-free operation with toxic or corrosive media owing to the hermetically sealed motor
 - No shaft seals towards atmosphere, therefore high reliability, long service intervals and no oil leaks
- Conversion from vertical to horizontal pumping action can be done from the side of the customer (for WH 4400/7000)

- Secure operation and faster pump down in short cycle operation with optional bypass-line (does not apply to WH 700)
- Motor protection PTC and PTO

RUVAC WHU with Bypass Line

- Maximum efficiency in short cycle operation for the WHU types with bypass line and newly developed control flap
- Reduced pumpdown time
- Pump start-up at atmospheric pressure possible
- Maximum pumpdown time with bypass line active not over three minutes
- Optimized cycle time for the control flap (patent pending); delivers an even faster response compared to operation with frequency converter
- Extreme contamination resistance of the control flap

Typical Applications

The Roots pumps of the WH series were developed for deployment in all applications with high requirements regarding operating pressure, cycle times and system uptime.

- Display production processes
- Solar industry
- Furnace construction
- Industrial coating processes
- Research
- Space simulation

Supplied Equipment

- Pump will be delivered with standard shock absorbers
- Gasket in the intake flange with dirt sieve
- The required lubricant is included in separate bottles

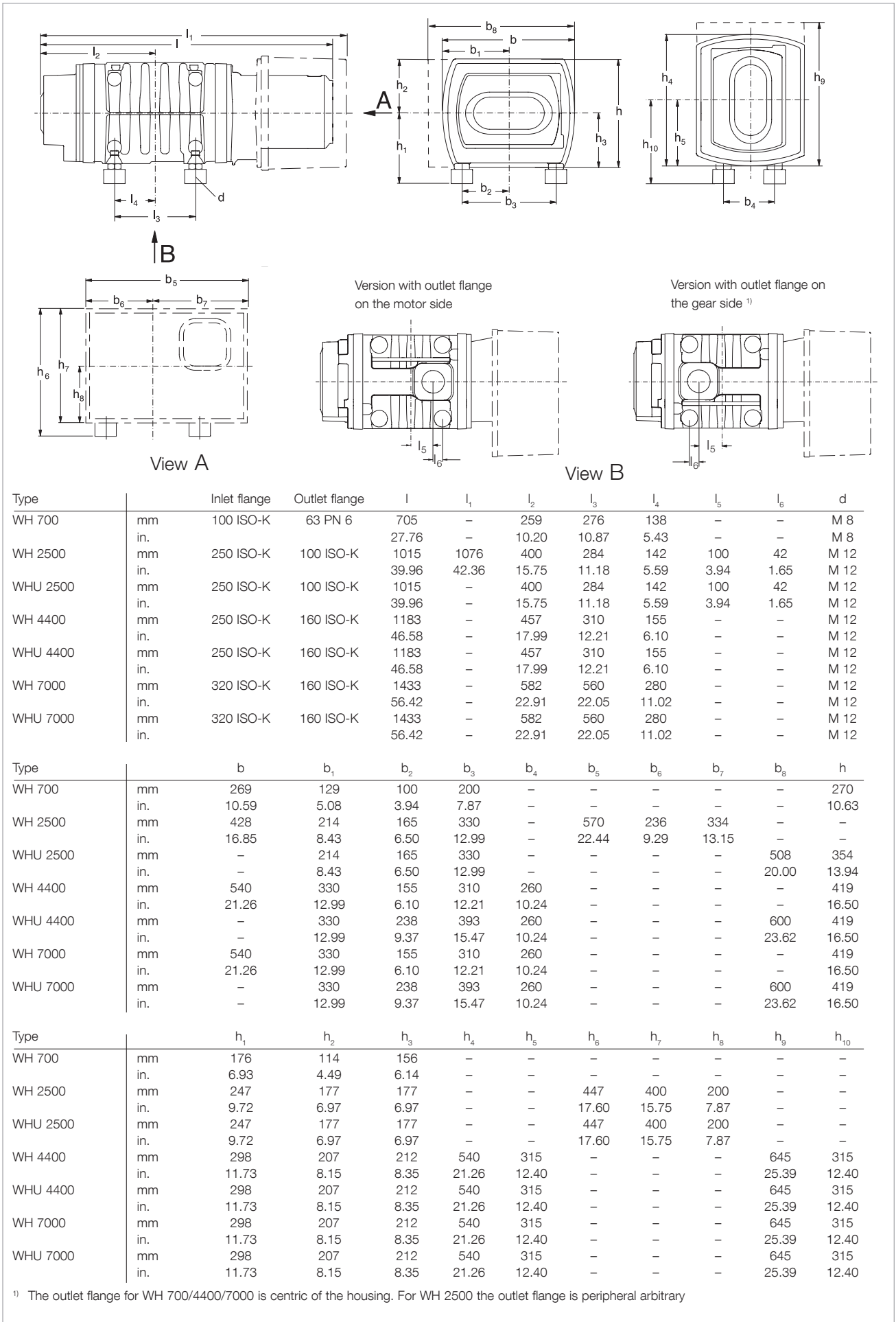

Dimensional drawing for the RUVAC WH/WHU pumps

Technical Data

WH 700

		50 Hz	60 Hz	50 Hz	60 Hz
Nominal pumping speed ²⁾	m ³ /h (cfm)	710 (418)	860 (507)	1150 (677)	1730 (1019)
Max. effective pumping speed with backing pump SOGEVAC SV 300 B	m ³ /h (cfm)	620 (365)	740 (436)	950 (560)	1310 (772)
Max. permissible pressure difference during continuous operation ^{3), 4), 5)}	mbar (Torr)	75.0 (56.3)	65.0 (48.8)	50.0 (37.5)	30.0 (22.5)
Leak rate, integral	mbar x l/s	< 1 x 10 ⁻⁵			
Mains voltage					
FC operation	V	340 to 530 180 to 260	340 to 530 180 to 260 ⁶⁾	340 to 530 180 to 260	340 to 530 180 to 260
Mains operation	V	360 to 440 180 to 260	410 to 500 210 to 260 ⁶⁾	– –	– –
Max. permissible pressure difference at mains voltage ⁵⁾					
200 V	mbar (Torr)	50.0 (37.5)	50.0 (37.5)	40.0 (30.4)	40.0 (30.4)
400 V	mbar (Torr)	60.0 (45.6)	60.0 (45.6)	45.0 (34.2)	45.0 (34.2)
Permissible ambient temperatures	°C (°F)	+5 to +45 (+41 to +113)			
Nominal power consumption					
FC operation	kW (hp)	3.5 (4.7)	3.5 (4.7)	3.5 (4.7)	3.5 (4.7)
Mains operation	kW (hp)	2.2 (2.9)	2.2 (2.9)	–	–
Idle mode power consumption	kW (hp)	0.5 (0.7)			
Energy efficiency class		IE 2			
Nominal speed	rpm	3000	3600	4800	7200
Max. permissible speed ⁷⁾	rpm ¹	7200			
Type of protection	IP	55			
Water connection (4 pcs.)	G	1/4", female			
Cooling water quantity ⁸⁾	l/min	1 to 3			
Cooling water admission temperature	°C (°F)	5 to 35 (+41 to +95)			
Permissible cooling water pressure	bar	2 to 6			
Lubricant ⁹⁾					
gear side	l (qt)	0.6 (0.63)			
motor side	l (qt)	0.3 (0.31)			
Connection flange					
Inlet	ISO-K	100			
Outlet	ISO-K	63			
Weight	kg (lbs)	125 (276)			
Dimension (W x B x H)	mm (in.)	709 x 265 x 270 (27.91 x 10.43 x 10.63)			
Noise level ¹⁰⁾	dB(A)	< 56	< 56	< 60	< 60

¹⁾ Only possible with frequency converter motor and external frequency converter

²⁾ To DIN 28 426 and subsequent numbers

³⁾ Higher pressure differences are possible. Please contact Leybold (LV)

⁴⁾ Gas temperatures over 40 °C (104 °F) can result in a reduction of the pressure difference values; please consult LV on this

⁵⁾ The optional frequency converter automatically reduces the rotational speed of the rotors so as to compensate for overloads. During operation do not expose the pump to sudden pressure increases like shock venting to atmospheric pressure, for example

⁶⁾ Requires 200 V FC variant and 200 V motor

⁷⁾ Min. permissible speed: 1200 rpm if run for more than 1 hour

⁸⁾ The cooling water quantity can be reduced provided the temperature of the discharged water does not exceed 45 °C (113 °F)

⁹⁾ Authoritative, however, is the oil level at the oil-level glass

¹⁰⁾ Valid under ultimate pressure conditions. Pressures over 10 mbar (7.5 Torr) produce a higher operating noise

Ordering Information

WH 700

	Part No.
Roots vacuum pump RUVAC WH Roots vacuum pump 3.8 kW 400 V, Internal FC, IP 55, PFPE oil (LVO 400) Ester oil (LVO 210)	167 186V 167 189V
2.2 / 2.6 kW for direct inline operation 50/60 Hz 400 / 460 V, Ester oil (LVO 210) 400 V, PFPE oil (LVO 400)	155 203 155 208V
3.5 kW for FC operation (external FC) 200 V, Ester oil (LVO 210) 400 V, Ester oil (LVO 210) 400 V, PFPE oil (LVO 400) 200 V, PFPE oil (LVO 400)	155 204V 155 205V 155 207V 155 209V
Accessories	
Frequency converter with integrated mains filter 200 / 240 V, motor power 4 kW (for Part. No. 155 204V)	155 218V
400 / 480 V, motor power 4 kW (for Part. No. 155 205V and 155 207V)	155 217V
400 V, motor power 4 kW, IP 66 (for Part. No. 155 ??? and 155 ???)	155 219V
LCD Display (for Part No. 155 217V and 155 218V)	155 213V
USB Copy Unit (for Part No. 155 217V and 155 218V)	155 214V
Profibus DP module ¹⁾ (for Part No. 155 217V and 155 218V)	155 212V
ProfiNet module for (DRYVAC/LEYVAC/RUVAC)	112005A35
EtherCAT module for (DRYVAC/LEYVAC/RUVAC)	112005A36
Relay modul (digital output) for (DRYVAC/LEYVAC/RUVAC)	112005A01
Ethernet interface board for (DRYVAC/LEYVAC/RUVAC)	112005A02
Oil drain facility (M 16 x 1.5) with 90° drain coupling	200 14 271
Reducer DN 100/63 ISO-K	267 47
Spare Parts	
Major maintenance kit	EK 110 002 691

¹⁾ For further bus options please contact Leybold Sales

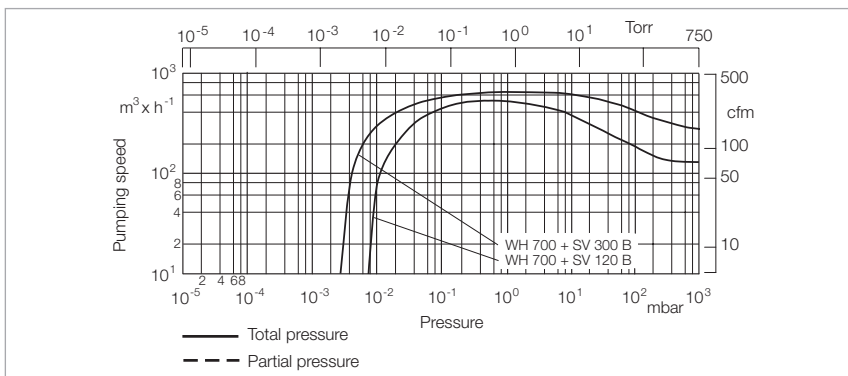

Pumping speed of the RUVAC WH 700

Technical Data

WH/WHU 2500

		50 Hz	60 Hz	80 Hz ¹⁾	100 Hz ¹⁾
Nominal pumping speed ²⁾	m ³ /h (cfm)	2500 (1473)	3000 (1767)	4000 (2356)	5000 (2945)
Max. effective pumping speed with backing pump DRYVAC DV 650	m ³ /h (cfm)	2200 (1296)	2500 (1473)	3200 (1885)	3900 (2297)
Max. permissible pressure difference ^{3), 4), 5)} during continuous operation (WH) for short-cycle operation < 2 min. (WHU)	mbar (Torr)	50 to 75 (37.5 to 56.3)	40 to 60 (30.0 to 45.0)	30 to 40 (22.5 to 30.0)	20 (15.0)
	mbar (Torr)	160 (120)	160 (120)	–	–
Leak rate, integral	mbar x l/s	< 1 x 10 ⁻⁵			
Mains voltage FC operation	V	340 to 530 180 to 260	340 to 530 180 to 260	340 to 530 180 to 260	340 to 530 180 to 260
	Mains operation	V	360 to 440	410 to 500	–
Permissible ambient temperatures	°C (°F)	+5 to +50 (+41 to +122)			
Nominal power rating FC operation (WH) Mains operation WH WHU	kW (hp)	11.0 (14.8)	11.0 (14.8)	11.0 (14.8)	11.0 (14.8)
	kW (hp)	6.2 (8.4)	7.4 (10.1)	–	–
	kW (hp)	6.2 (8.4)	7.4 (10.1)	–	–
Idle mode power consumption	kW (hp)	1.1 (1.5)	1.2 (1.6)	1.5 (2.0)	1.7 (2.3)
Energy efficiency class		IE 2			
Nominal speed	rpm	3000	3600	4800	6000
Max. permissible speed with FC ⁶⁾	rpm	6000			
Type of protection (int. FC/ext. FC)	IP	54/55			
Cooling water connection (2 pcs.)	G	1/4", female			
Cooling water quantity ⁷⁾	l/min	1 to 3			
Cooling water admission temperature	°C (°F)	5 to 35 (+41 to +95)			
Permissible cooling water pressure	bar	2 to 6			
Lubricant ⁸⁾	l (qt)	1.2 (1.27)			
Connection flange Inlet Outlet	ISO-K	250			
	ISO-K	100			
Weight WH/ WHU WH with integrated FC	kg (lbs)	390/410 (861/905)			
	kg (lbs)	430 (946)			
Dimension (W x B x H) WH/ WHU WH with integrated FC	mm (in.)	1015 x 428 x 354 (39.96 x 16.85 x 13.94)			
	mm (in.)	(42.36 x 22.44 x 13.94)			
Noise level ⁹⁾	dB(A)	< 63			

¹⁾ Only possible with frequency converter motor or external frequency converter

²⁾ To DIN 28 426 and subsequent numbers

³⁾ Higher pressure differences are possible. Please contact Leybold (LV)

⁴⁾ Gas temperatures over 40 °C (104 °F) can result in a reduction of the pressure difference values; please consult LV on this

⁵⁾ The optional frequency converter automatically reduces the rotational speed of the rotors so as to compensate for overloads. During operation do not expose the pump to sudden pressure increases like shock venting to atmospheric pressure, for example

⁶⁾ Min. permissible speed: 1200 rpm if run for more than 1 hour

⁷⁾ The cooling water quantity can be reduced provided the temperature of the discharged water does not exceed 45 °C (113 °F)

⁸⁾ Authoritative, however, is the oil level at the oil-level glass

⁹⁾ Valid under ultimate pressure conditions. Pressures over 10 mbar (7.5 Torr) produce a higher operating noise

Technical Data

WH/WHU 4400

WH/WHU 7000

		50 Hz	60 Hz	80 Hz ¹⁾	50 Hz	60 Hz	70 Hz ¹⁾
Nominal pumping speed ²⁾	m ³ /h (cfm)	4400 (2592)	5280 (3100)	7040 (4147)	7000 (4123)	8400 (4948)	9800 (5772)
Max. effective pumping speed with backing pump							
DRYVAC DV 650	m ³ /h (cfm)	3300 (1944)	3900 (2297)	4800 (2827)	4700 (2768)	5300 (3122)	5800 (3416)
and RUVAC WH 2500	m ³ /h (cfm)	3700 (2179)	4400 (2592)	5800 (3416)	5700 (3357)	6800 (4005)	7800 (4594)
Max. permissible pressure difference ^{3), 4), 5)}							
during continuous operation (WH)	mbar (Torr)	30 to 45 (22.5 to 33.75)	20 to 30 (15.0 to 22.5)	8 to 12 (6.0 to 9.0)	0 to 30 (15.0 to 22.5)	14 to 21 (10.5 to 15.75)	11 to 14 (8.25 to 10.5)
for short-cycle operation < 2 min. (WHU)	mbar (Torr)	120 (90)	120 (90)	–	60 (45)	60 (45)	–
Leak rate, integral	mbar x l/s	< 1 x 10 ⁻⁵					
Mains voltage							
FC operation	V	340 to 530 180 to 260	340 to 530 180 to 260 ⁶⁾	340 to 530 180 to 260	340 to 530 180 to 260	340 to 530 180 to 260 ⁶⁾	340 to 530 180 to 260
Mains operation	V	360 to 440 180 to 220	410 to 500 210 to 260 ⁶⁾	– –	360 to 440 180 to 220	410 to 500 210 to 260 ⁶⁾	– –
Permissible ambient temperatures	°C (°F)	+5 to +40 (+41 to +104)					
Nominal power consumption (alternatively)							
FC operation	kW (hp)	11.0 / 15.0 (14.75 / 20.12)	11.0 / 15.0 (14.75 / 20.12)	11.0 / 15.0 (14.75 / 20.12)	11.0 / 15.0 (14.75 / 20.12)	11.0 / 15.0 (14.75 / 20.12)	11.0 / 15.0 (14.75 / 20.12)
Mains operation	kW (hp)	11.0 / 18.5 (14.75 / 24.81)	11.0 / 18.5 (14.75 / 24.81)	– –	11.0 / 18.5 (14.75 / 24.81)	11.0 / 18.5 (14.75 / 24.81)	– –
Idle mode power consumption	kW (hp)	0.7 (1.0)	0.8 (1.1)	1.0 (1.4)	0.9 (1.2)	1.0 (1.4)	1.2 (1.6)
Energy efficiency class		IE 2					
Nominal speed	rpm	3000	3600	4800	6000	3600	4200
Max. permissible speed ⁷⁾	rpm	4800	4800	4800	4200	4200	4200
Type of protection	IP	54					
Cooling water connection (2 pcs.)	G	1/4", female					
Cooling water quantity ⁸⁾	l/min	1 to 3					
Cooling water admission temperature	°C (°F)	5 to 35 (+41 to +95)					
Permissible cooling water pressure	bar	2 to 6					
Lubricant ⁹⁾	l (qt)	4.75 (5.0)					
Connection flange							
Inlet	ISO-K	250	250	250	320	320	320
Outlet	ISO-K	160	160	160	160	160	160
Weight							
WH	kg (lbs)	590 (1301)	590 (1301)	590 (1301)	650 (1433)	650 (1433)	650 (1433)
WHU	kg (lbs)	620 (1369)	620 (1369)	620 (1369)	715 (1578)	715 (1578)	715 (1578)
Dimension (W x B x H)	mm (in.)	1183 x 540 x 415 (46.57 x 21.26 x 16.34)	1183 x 540 x 415 (46.57 x 21.26 x 16.34)	1183 x 540 x 415 (46.57 x 21.26 x 16.34)	1433 x 540 x 415 (46.57 x 21.26 x 16.34)	1433 x 540 x 415 (46.57 x 21.26 x 16.34)	1433 x 540 x 415 (46.57 x 21.26 x 16.34)
Noise level ¹⁰⁾	dB(A)	< 63					

¹⁾ Only possible with external frequency converter

²⁾ To DIN 28 400 and subsequent numbers

³⁾ Higher pressure differences are possible. Please contact Leybold (LV)

⁴⁾ Gas temperatures over 40 °C (104 °F) can result in a reduction of the pressure difference values; please consult LV on this

⁵⁾ The optional frequency converter automatically reduces the rotational speed of the rotors so as to compensate for overloads. During operation do not expose the pump to sudden pressure increases like shock venting to atmospheric pressure, for example

⁶⁾ Requires 200 V FC variant and 200 V motor

⁷⁾ Min. permissible speed: 1200 rpm if run for more than 1 hour

⁸⁾ The cooling water quantity can be reduced provided the temperature of the discharged water does not exceed 45 °C (113 °F)

⁹⁾ Authoritative, however, is the oil level at the oil-level glass

¹⁰⁾ Valid under ultimate pressure conditions. Pressures over 10 mbar (7.5 Torr) produce a higher operating noise

Ordering Information

RUVAC WH/WHU 2500

	Part No.
Roots vacuum pump RUVAC WH 400 V int. FC PFPE oil (LVO 410) gear side ¹⁾ motor side	155 250V 155 251V
Ester oil (LVO 210) gear side ¹⁾ motor side	155 252V 155 253V
ext. FC PFPE oil (LVO 410) gear side ¹⁾ motor side	155 260V 155 261V
Ester oil (LVO 210) gear side ¹⁾ motor side	155 262V 155 263V
without FC, DOL ²⁾ PFPE oil (LVO 410) gear side ¹⁾ motor side	155 270V 155 271V
Ester oil (LVO 210) gear side ¹⁾ motor side	155 272V 155 273V
200 V, ext. FC PFPE oil (LVO 410) gear side ¹⁾ motor side	155 265V 155 264V
RUVAC WHU without FC, DOL ²⁾ PFPE oil (LVO 410) 400 V gear side ¹⁾ motor side	155 280V 155 281V
200 V gear side ¹⁾ motor side	155 284V 155 285V
Ester oil (LVO 210) 400 V	155 288V

¹⁾ Discharge flange on the motor side (SOGEVAC and SCREWLINE) respectively gear side (DRYVAC)

²⁾ DOL is the mains power version for direct connection to 50 or 60 Hz mains power

Ordering Information

RUVAC WH/WHU

	4400 Part No.	7000 Part No.
Roots vacuum pump RUVAC WH-Ester oil (LVO 210) 11.0 kW, 400 V 18.5 kW, 400 V 18.5 kW, heavy duty ¹⁾ 18.5 kW, heavy duty, ATEX Cat. 2i ¹⁾	155 150 - 155 154V -	155 160 155 167 155 163V 155 163V11
RUVAC WH-Ester oil (LVO 210) 11.0 kW, 400 V, int. FC, IP 55	167 193V	167 194V
RUVAC WH-PFPE oil (LVO 400), 11.0 kW 400 V 200 V	155 155 155 156	155 165 155 164V
RUVAC WH-Ester oil (LVO 210), 11.0 kW 200 V	155 151V	155 161V
RUVAC WHU, 18.5 kW, bypass valve Ester oil (LVO 210) PFPE oil (LVO 400)	155 158V 155 153	155 162 -

¹⁾ With large motor, gas-sealed impellers and purge gas

Ordering Information

RUVAC WH/WHU

	2500	4400	7000
	Part No.	Part No.	Part No.
Accessories			
Frequency converter, inclusive mains filter			
11 kW / 200 V	155 231V	155 193V	155 193V
11 kW / 400 V	155 230V	155 191V	155 191V
18 kW / 400 V	-	155 192V	155 192V
11 kW / 400 V, IP 66	-	155 187V	155 187V
18 kW / 400 V, IP 66	-	155 187V	155 187V
LCD display (for Part. No. 155 191V, 155 192V and 155 193V)		155 213V	
Profibus DP module (for Part. No. 155 191V, 155 192V and 155 193V)		155 212V	
ProfiNet module für (DRYVAC/LEYVAC/RUVAC)		112005A35	
EtherCAT module for (DRYVAC/LEYVAC/RUVAC)		112005A36	
Relay module (digital output) for (DRYVAC/LEYVAC/RUVAC)		112005A01	
Ethernet interface board for (DRYVAC/LEYVAC/RUVAC)		112005A02	
LEYASSIST Windows Software ¹⁾		230439V01	
RS232 adapter for DRYVAC RUVAC WH		155224V	
Adapter USB / RS232		800110V0103	
Pump feet set for horizontal operation	-	155 181V	155 181V
Gear chamber evacuation kit	-	155 183V	155 183V
Spare Parts			
Major maintenance kit	EK 110 003 000	EK 110 002 828	EK 110 002 828
Spare motor, 400 V			
11.0 kW	-	E 110 000 406	E 110 000 406
15.0 kW	upon request	-	-
18.5 kW	-	E 110 000 405	E 110 000 405

¹⁾ Operation, configuration and analysis software for RUVAC WH with frequency converter, DRYVAC and further Leybold products

Accessories

Pressure Switches

The RUVAC vacuum pumps may be switched on and off automatically through a pressure switch driven by a SV 110 switching amplifier and a contactor.

The pressure switch may be installed in the intake of the RUVAC using a screw-in adaptor, an elbow and two centering and two clamping rings.

Upon request the pressure switch may be set by Leybold to a fixed value. Please state this pressure value in your order.

Ordering Information

Pressure Switches

	Part No.
Pressure switch	
PS 115, adjustable setting	160 04
Pressure switch setting	160 05
Accessories for fitting the PS 115 pressure switch	
Screw-in adaptor DN 16 ISO-KF, M 16 x 1.5 mm (0.06 in.)	168 40
Elbow DN 16 KF	184 36
Centering ring DN 16 KF (2 are required)	183 26
Clamping ring DN 16 KF (2 are required)	183 41
SV 110 switching amplifier (for PS 114/115)	160 78
Oil pressure switch for RUVAC WSLF 1001 and WS-PFPE	194 82

Temperature Sensor Pt100

The temperature sensor measures the gas temperature at the centre of the RUVAC delivery flange.

Depending on the size of the RUVAC pump, respectively its flange size, the Pt100 sensor is fitted at different positions.

Ordering Information

Temperature Sensor

	Part No.
Temperature sensor Pt100	155 010

Genuine Maintenance Spare Parts and Kits

Keeping the availability and the performance of your equipment at the maximum level is key for us as well as for your business. Regular maintenance with genuine spare parts is crucial to ensure an excellent and reliable pump performance, to avoid pump breakdowns and to reduce unforeseen service costs. Genuine parts will keep your pump fit for a long time.

Ordering Information

Kit description	Sealing set for oil exchange	Minor maintenance kit	Major maintenance kit
Standard service interval	0.5 years (not for PFPE versions)	1 year	5 years
RUVAC Model	Part No.	Part No.	Part No.
WA 251	ES23 955 165	EK 110 002 661	EK 110 002 663
WA 501		EK 110 002 661	EK 110 002 664
WA 1001		EK 110 002 662	EK 110 002 667
WA 2001		EK 110 002 662	EK 110 002 669
WAU 251		EK 110 002 661	EK 110 002 662
WAU 501		EK 110 002 661	EK 110 002 662
WAU 1001		EK 110 002 662	EK 110 002 668
WAU 2001		EK 110 002 662	EK 110 002 670
Standard service interval	1 year (not for PFPE versions)	1 year	4 years
RUVAC Model	Part No.	Part No.	Part No.
WS 251	ES23 955 165	–	EK 110 002 671
WS 501		–	EK 110 002 672
WS 1001		–	EK 110 002 673
WS 2001		–	EK 110 002 674
WSU 251		–	EK 110 002 675
WSU 501		–	EK 110 002 676
WSU 1001		–	EK 110 002 677
WSU 2001		–	EK 110 002 678
WH 700		–	EK 110 002 691
WH 2500		–	EK 110 003 000
		–	EK 110 003 002
WH 4400		–	EK 110 002 828
		–	EK 110 002 835
WH 7000		–	EK 110 002 828
WH 7000 ATEX 2i		–	EK 110 002 840
WHU 2500		–	EK 110 003 000
		–	EK 110 003 002
		–	EK 110 002 835
WHU 4400	–	EK 110 002 828	
	–	EK 110 002 835	
WHU 7000	–	EK 110 002 828	
	–	EK 110 002 836	

Please note that oil is not included with the maintenance kits listed above. Oil has to be ordered separately. Specified standard service intervals are for normal use, the period may vary depending on the application (longer/shorter). Minor and major maintenance kits comprise sealing sets. For further spares or kits, please have a look at the the spare parts list or contact your local customer center.

Miscellaneous

Services

On-site Replacement of the Dynamic Seals (with oil LVO 100) *)

The on-site replacement of the dynamic seals includes the following:

Oil change (standard oil LVO 100), partial disassembly of the pump, replacement of the complete shaft seal, visual inspection of the subassemblies, electrical safety test, test run including check of the attained ultimate pressure levels (depending on the installation situation)

Ordering Information

On-site Replacement of the Dynamic Seals (with oil LVO 100) *)

	Part No.
For pump	
WA/WAU 151/251	AS 1181 F
WA/WAU 501	AS 1182 F
WA/WAU 1001	AS 1183 F
WA/WAU 2001	AS 1184 F

Small On-site Maintenance (with oil LVO 100) *)

The small on-site maintenance includes the following:

Oil change (standard oil LVO 100), visual inspection of the subassemblies, electrical safety test, test run including check of the attained ultimate pressure levels (depending on the installation situation)

Ordering Information

Small On-site Maintenance (with oil LVO 100) *)

	Part No.
For pump	
WA/WAU 151/251	AS 1185 F
WA/WAU 501	AS 1186 F
WA/WAU 1001	AS 1187 F
WA/WAU 2001	AS 1188 F

*) Notes on our on-site after sales service

The listed services include the costs for material and working hours on site for standard RUVAC pumps. Services for pump variants upon request.

Transportation and travelling expenses are invoiced at cost. All services refer to the repair of freely accessible and not contaminated vacuum components.

Complete Refurbishing at the Service Centre (with oil LVO 100)

Complete refurbishing at the service centre includes the following:

Disassembly of the pump, cleaning of all individual components including visual inspection, machined reworking of the housing sections; if required rebalancing of the pair of impellers, replacement of the wearing parts, assembly of the pump including new seals and standard oil LVO 100, electrical safety test, test run including check of the attained ultimate pressure levels.

Ordering Information

Complete Refurbishing at the Service Centre (with oil LVO 100)

	Part No.
For pump	
WA 151/251	AS 1189
WA 501	AS 1190
WA 1001	AS 1191
WA 2001	AS 1192
WS 151/251	AS 1193
WS 501	AS 1194
WS 1001	AS 1195
WS 2001	AS 1196
WAU 151/251	AS 1197
WAU 501	AS 1198
WAU 1001	AS 1199
WAU 2001	AS 1200
WSU 151/251	AS 1201
WSU 501	AS 1202
WSU 1001	AS 1203
WSU 2001	AS 1204

Complete Refurbishing with Decontamination at the Service Centre (with oil LVO 100)

Complete refurbishing with decontamination at the service centre includes the following:

Disassembly of the pump, cleaning and decontamination of all individual components, visual inspection of all components, machined reworking of the housing sections; if required rebalancing of the pair of impellers, replacement of the wearing parts, assembly of the pump including new seals and standard oil LVO 100, electrical safety test, test run including check of the attained ultimate pressure levels.

Ordering Information

Complete Refurbishing with Decontamination at the Service Centre (with oil LVO 100)

	Part No.
For pump	
WA 151/251	AS 1189 D
WA 501	AS 1190 D
WA 1001	AS 1191 D
WA 2001	AS 1192 D
WS 151/251	AS 1193 D
WS 501	AS 1194 D
WS 1001	AS 1195 D
WS 2001	AS 1196 D
WAU 151/251	AS 1197 D
WAU 501	AS 1198 D
WAU 1001	AS 1199 D
WAU 2001	AS 1200 D
WSU 151/251	AS 1201 D
WSU 501	AS 1202 D
WSU 1001	AS 1203 D
WSU 2001	AS 1204 D