

Valves

Valves

Right-Angle and Straight-Through Valves

Special Valves

Gate Valves

UHV Valves

Contents

Valves

General

The Leybold Valve Program	5
---------------------------------	---

Products

Small Valves of the “micro” Range	9
--	----------

Overview	9
----------------	---

Right-Angle and Straight-Through Valves, Bellows-Sealed, Various Drives	10
---	----

Valves with ISO-KF Flanges.....	13
--	-----------

Overview	13
----------------	----

Right-Angle Valves, Bellows-Sealed, Manually Operated	14
--	----

Straight-Through Valves, Bellows-Sealed, Manually Operated	15
---	----

Right-Angle Valves, Bellows-Sealed, (Electro)pneumatically Operated	16
--	----

Straight-Through Valves, Bellows-Sealed, (Electro)pneumatically Operated.....	18
---	----

Right-Angle Valves, Electromagnetically Operated	20
---	----

Right-Angle Valves with ISO-K Flanges	23
--	-----------

Overview	23
----------------	----

Manually Operated	24
-------------------------	----

Electropneumatically Operated	26
-------------------------------------	----

Special Valves with ISO-KF/ISO-K/CF Flange	28
---	-----------

Overview	28
----------------	----

SECUVAC Vacuum Safety Valves	29
------------------------------------	----

Interference Suppression Kit – Illuminated.....	31
---	----

Pressure Relief Valve.....	32
----------------------------	----

Power Failure Venting Valves, Electromagnetically Actuated.....	33
--	----

Variable Leak Valve with Isolation Valve	34
--	----

Venting Valves,	35
-----------------------	----

Manually Operated	35
-------------------------	----

Electromagnetically Actuated.....	36
-----------------------------------	----

Vacuum Locks and Sealing Valves.....	38
--------------------------------------	----

Ball Valves	40
-------------------	----

Accessories for the Electropneumatically Operated Valves	41
---	-----------

Pilot Valves	41
--------------------	----

Interference Suppression Kit – Illuminated.....	41
---	----

Special Valves for Turbomolecular Pumps.....	42
--	----

UHV All-Metal Right-Angle Valves	44
UHV All-Metal Variable Leak Valves.....	45
Gate Valves	
with ISO-KF / CF / ISO-F Flanges	47
Overview	47
Miniature Gate Valves, ISO-KF, Manually Operated (Articulated Lever).....	48
Miniature UHV Gate Valves, ISO-KF and CF,	50
Manually Operated (Handwheel)	50
Electropneumatically Operated	52
HV Gate Valves, ISO-F.....	54
Manually Operated	54
Electropneumatically Operated	56
UHV Gate Valves, CF	
Manually Operated	58
UHV Gate Valves, ISO-F,	
Electropneumatically Operated	60
UHV Gate Valves, CF,	
Electropneumatically Operated	62

General

The Leybold Valve Program

The long-standing experience of Leybold in the area of vacuum engineering is reflected in the selection and the design of the valves and vacuum protection components for a wide variety of applications.

The range of products is such that a reliable solution can be offered for every vacuum engineering application. Many years of service and the reliability of the valves is ensured by design. Leybold valves are well-proven in many widely varying areas of research and industry.

The Design of a Vacuum Valve Scope of the Range of Valves

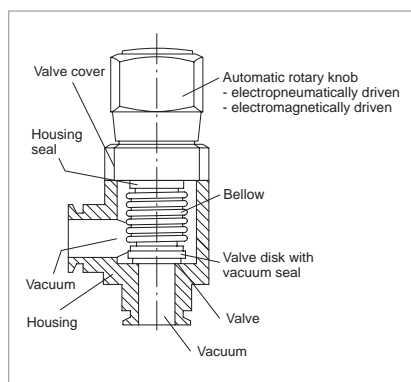

The range of Leybold valves comprises:

- Small valves **micro**
- Right-angle and straight-through valves with a nominal width of DN 16 to DN 40 with ISO-KF flanges
- Right-angle valves with a nominal width of DN 63 to DN 250 with ISO-K flanges
- Gate valves with a nominal width of DN 16 to DN 250 with various flanges
- Ball valves
- Special valves

It is the aim of Leybold to meet, through the offered range of isolation components and valves, the customers requirements regarding the design of such components. For this reason all valves are available with different driving systems.

With the exception of the special valves you may select between an electro-pneumatic drive or an electro-magnetic drive system.

Right-angle valves DN 16 ISO-KF to DN 40 ISO-KF as well as DN 63 ISO-K to DN 160 ISO-K are either available with an Aluminum or stainless steel body (the latter up to DN 100 ISO-K only).

The special characteristics of the application in each case result in special requirements concerning features of the valves, for example:

- Coating
 - Short switching cycles (e.g. 1.5 s)
 - Very high number of opening and switching cycles (e.g. over 10 million cycles)
- Analytical engineering
 - High conductance (similar to the corresponding flange components, like bends, for example)
 - High integral leak tightness for the valves (leak rates below 10^{-9} mbar l/s)
- Lamps and tubes manufacture
 - Temperature resistant
 - Permissible ambient temperatures, 50 °C max.
- Accelerator technology
 - Materials capable of resisting radiation, high temperatures and corrosion at the same time
- Metallurgy and furnace manufacture
 - Rugged and insensitive to contamination
- Chemistry
 - Choice of materials in contact with the medium for the valve body

All applications have the following requirements in common:

- Quiet opening action with very little vibration
- Compact design, low weight
- Highly visible, unambiguous position indicator
- For use within the pressure range from 10^{-8} to 2500 mbar, if not stated otherwise
- Fully operational within the entire specified pressure range

Leybold valves meet these requirements, unless otherwise stated by the technical data.

Quality Assurance

The various markets, like Analytical or Coating, for example are very demanding regarding certain important features for the valves which are to be used in the new generation of instruments currently under development. Demanded are, among other things, high reliability during the entire service life, high integral leak tightness, a high number of opening/closing cycles as well as a fast response.

The valves from Leybold meet all these demanding requirements!

For further information on flange connections and flange components please refer to Catalog Parts "Flanges and Fittings" and "Feedthroughs".

Flange Designations

The flange designations used in this Catalog Part are in line with the international standards and the nomenclature used in practice:

Flange Type	Standard	Designation with standardized nominal width ¹⁾ (DN)
Small flanges	ISO 2861/1	"ISO-KF"
	DIN 28 403	e.g. DN 40 ISO-KF
Clamp flanges	ISO 1609	"ISO-K"
	DIN 28 404	e.g. DN 100 ISO-K
Fixed flanges/ collar flanges with retaining ring	ISO 1609	"ISO-F"
	DIN 28 404	"F" for fixed flange e.g. DN 250 ISO-F

In the case of gate valves equipped with CF flanges the following must be noted:

The designation DN 35 CF for UHV flanges has been changed to DN 40 CF with the sealing parameters remaining unchanged; the same applies to DN 150 CF which has changed to DN 160 CF.

Advantages to the User

- Compact design
- Integral leak rate less than 10^{-8} mbar l/s
- FPM (FKM) sealed
- For pressures up to 2000 mbar
- Seal in both directions ²⁾
- Principal dimensions comparable to Leybold flange components of the same nominal width
- Reliable operation ensured regardless of the valve's orientation
- Optical valve position indicator as standard (not for valves of the "micro" range)
- Electrical valve position indicator as standard (not for valves of the "micro" range)
- Operation of electromagnetic ISO-KF valves off supply voltages ranging from 100 to 230 V AC
- The inside of the housing in contact with the medium is sealed off against the atmosphere by a bellows type seal which is free of lubricants.

All further technical data as well possible deviations from the general specifications stated here can be found along with the descriptions for the individual valve types.

For various applications and special design requirements Leybold offers a range of special valves:

- SECUVAC vacuum safety valves (DN 16 ISO-KF to DN 100 ISO-K)
- Venting valves / power failure venting valves
- Vacuum locks / sealing valves
- Variable leak valves
- Ball valves (straight-through valve)

Accessories

All connecting components like centering rings, clamps or clamping rings needed to connect the valves must be ordered separately (see Catalog Parts "Flanges and Fittings" and "Feedthroughs").

Materials

The valve bodies and the inside parts are made of selected, vacuum compatible materials, like wrought aluminum or cast stainless steel.

The raw components are subjected to a 100% test before they are further processed.

The materials which are used are described in the tables at the end of the chapter "General".

Gaskets

Shown in the table at the end of the chapter "General" are the types of gasket used in the valves together with their brief or chemical designations and their thermal ratings.

Other Materials

Plastic:	Polyamide 6 (PA 6)
Grey cast iron:	GG 20 (0.6020)
Brass:	Ms 58
Brass (nickel-plated):	CuZn39Pb3
Nimonic	
Bronze	
Spring steel	

¹⁾ The standardized nominal width (DN) corresponds approximately to the inside diameter, but need not necessarily be identical to the inside diameter.

²⁾ High vacuum systems are very demanding as to the leak tightness of the vacuum components used. For this reason each individual Leybold valve is subjected to a helium leak test before delivery. The valves are only considered as leak tight, if a leak rate of less than 10^{-9} mbar x l/s can be measured for the body and the valve seat.

In the case of our high vacuum valves with ISO-KF and ISO-K flanges a leak rate of less than 10^{-9} mbar x l/s is maintained also during actuation.

This means that in the case of a gas flow of the mentioned order of magnitude the pressure would increase only by 3 mbar in a vessel of 1 liter and in 100 years.

Materials

Aluminum Alloys

Material No.		Brief Designation
DIN	AA	DIN
3.0615	–	AlMgSiPbF28
3.2153	–	G AlSi7Cu3
3.2315	6081	AlMgSi1F28
3.2341	–	G AlSi5Mg wa
3.2371	–	G AlSi7Mg06
3.2373	–	G AlSi9Mg
3.2381	–	G AlSi10Mg wa
3.3527	–	AlMg2Mn0,8F20

Stainless Steels

Material No.		Brief Designation
DIN	AISI	DIN
1.4034	420	X 46 Cr 13
1.4301	304	X5 CrNi 18 10
1.4305	303	X10 CrNi 51 89
1.4306	304 L	X2 CrNi 18 10
1.4308	–	G-X6 CrNi 18 1
1.4310	301	X12 CrNi 17 7
1.4404	316 L	X2 CrNiMo 17 13 3
1.4435	316 L	X2 CrNiMo 18 14 3
1.4541	321	X10 CrNiTi 18 10
1.4571	316 Ti	X6 CrNiMoTi 17 12 2

Standard Steels

Material No.	Brief Designation
DIN	DIN
1.0388	St4/St14
1.0425	H II

Materials used for the Gaskets

Brief Designation	Chemical Designation	Typical Trade Name	Degassing Temperature
FPM (FKM)	Fluor caoutchouc	Viton	up to 150 °C
NBR	Acrylonitrile-butadiene rubber	Perbunan	up to 80 °C
PTFE	Polytetrafluor ethylene	Teflon	up to 250 °C
EPDM	Ethylene-propylenedien caoutchouc	–	up to 150 °C

Abbreviations used in the valve designations

Brief Designation	Valve Type
EMD	Solenoid straight-through valve
EME	Solenoid right-angle valve
EPD	Electropneumatic straight-through valve
EPE	Electropneumatic right-angle valve
MAN	Manual operation
PD	Pneumatic straight-through valve
PE	Pneumatic right-angle valve

Products

Small Valves of the “micro” Range

Overview

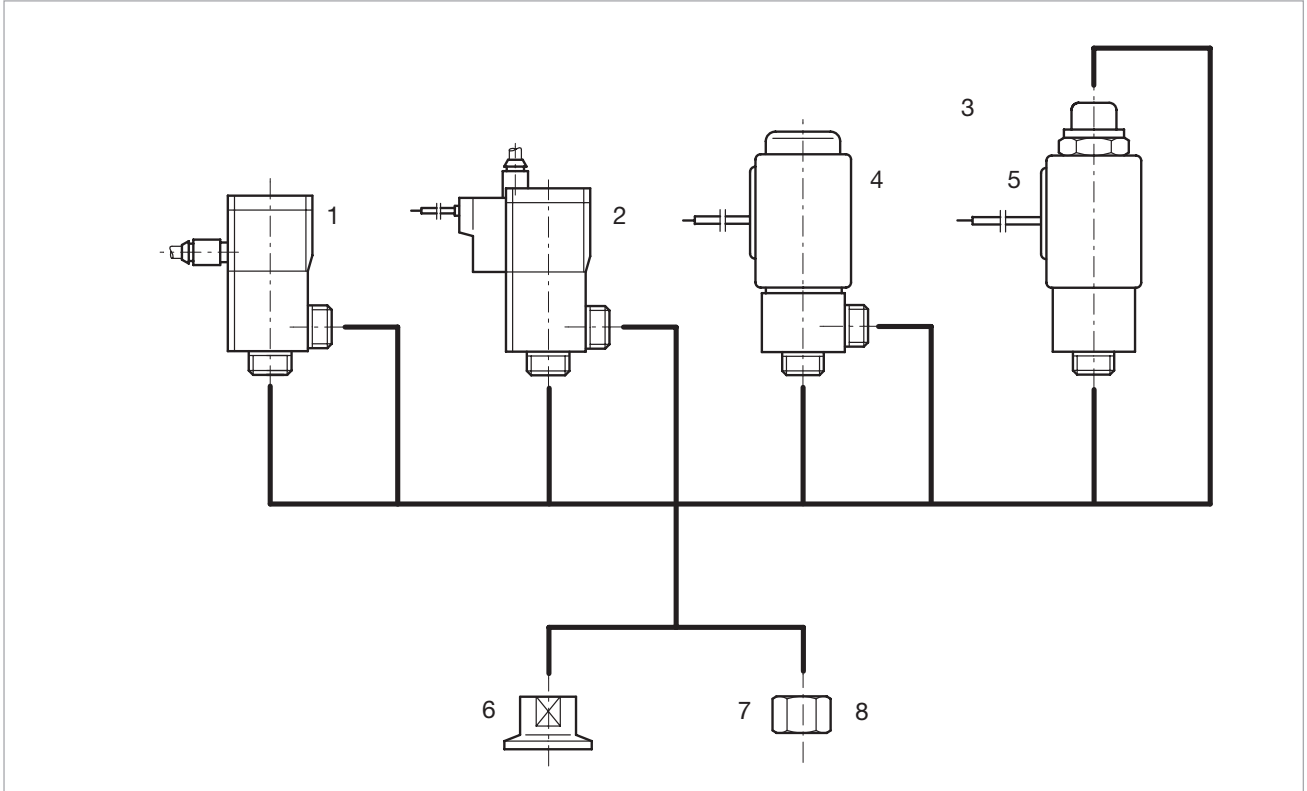

Leybold small valves **micro** are available with any of three drive systems, two types of body and three adaptors.

Types of drive

- Pneumatic (1)
- Electropneumatic (2)
- Electromagnetic (3)

Types of valve body

- Right-angle valve (4)
- Straight-through valve (5)

as well as adaptor

- DN 10 ISO-KF flange (6)
- 1/4" tube (7)
- 6 mm tube (8)

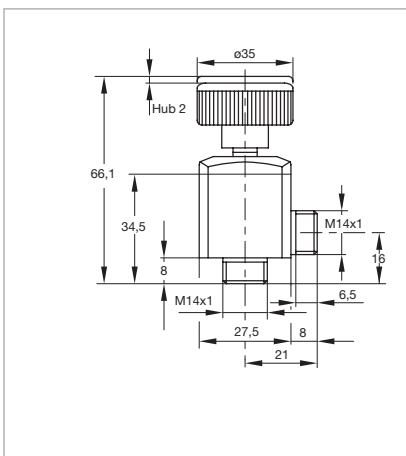

Dimensional drawing for the **micro MAN**

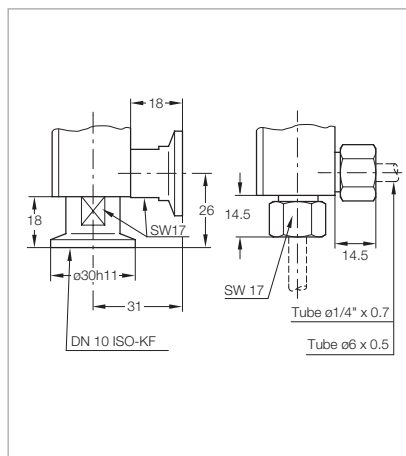

Connection dimensions for small valves **micro**

Technical Information

micro valves are supplied without adaptor.

The adaptors must be ordered additionally.

Right-Angle and Straight-Through Valves, Bellows-Sealed, Various Drives

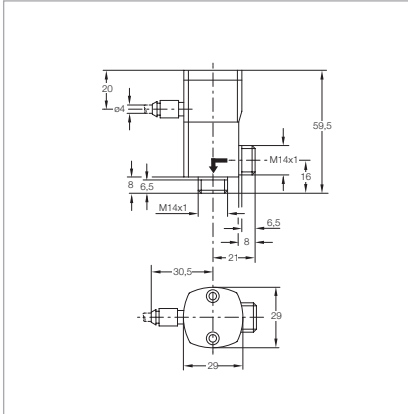

Dimensional drawing for the pneumatically actuated small valves **micro**

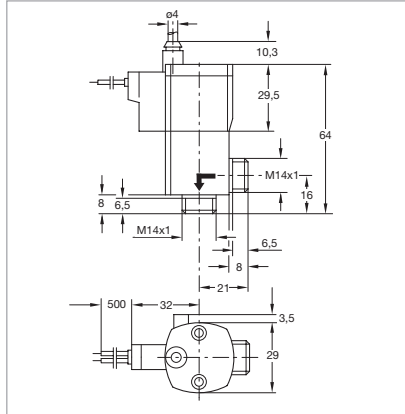

Dimensional drawing for the electropneumatically actuated small valves **micro**

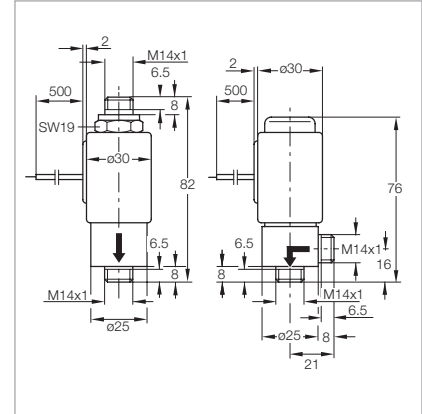

Dimensional drawing for the electromagnetic actuated small valves **micro**

Advantages to the User

- Small size
- High conductance in the molecular flow range
- Long service life of over 2 million switching cycles
- High switching frequency
- Protection class IP 50

Typical Applications

- Gas handling systems in production machines
- Latest generation analytical equipment

Technical Data

Small Valves "micro"

		Elektropneumatic	Pneumatic	Electromagnetic
Nominal width	mm	5	5	5
Integral leak rate	mbar x l/s	10 ⁻⁹	10 ⁻⁹	10 ⁻⁹
Switching cycles		5 millions	5 millions	5 millions
Max. pressure differential	bar abs.	3	3	1
Closure time	ms	35	35	7
Opening time	ms	35	35	30
Max. switching frequency	min ⁻¹	150	150	300
Conductance, molecular	l/s	0.4	0.4	0.3
Supply voltage	V DC	24 (with pilot valve)	-	24
Max. power consumption	W	1	-	10
Material				
Valve body		stainless steel (1.4301)	stainless steel (1.4301)	stainless steel (1.4301)
Inside section		stainless steel (1.4301)	stainless steel (1.4301)	stainless steel (1.4301)
Seals		O-rings of FPM (FKM)	O-rings of FPM (FKM)	O-rings of FPM (FKM)
Drive		aluminum anodized	aluminum anodized	stainless steel 1.4105

Ordering Information

Small Valves "micro"

	Part No.
Right-Angle Valves, normally closed	
Electropneumatic (with pilot valve)	284 41
Pneumatic (without pilot valve), with flanges DN 10 ISO-KF	284 47
Electromagnetic, 24 V DC	284 44
Straight-Through Valves, normally closed	
Electromagnetic, 24 V DC	284 45
Adaptor (1 piece)	
Flange DN 10 ISO-KF	284 50
Tube 1/4"	284 51
Tube 6 mm	284 52

Valves with ISO-KF Flanges

Overview



Leybold ISO-KF valves are available with any of four drive systems and four types of body having a nominal width of DN 16, 25, 40 and 50 ISO-KF.

Abbreviations used in connection with bellows sealed valves:

B Bellows sealed

A Angle (valve)

I Inline (valve)

V Valve

M Rotary knob

P Pneumatically actuated
(without pilot valve)

EP Electropneumatically actuated
(with pilot valve)

EM Electromagnetically actuated

AL Aluminum body

SS Stainless steel body

BAV ... EP AL ...

Types of drive

- Rotary knob **1**
with bellows seal
- Pneumatic **2**
with bellows seal
- Electropneumatic **3**
with bellows seal
- Electromagnetic **4**

Types of valve body

- Right-angle valve,
aluminum body **5**
- Right-angle valve,
stainless steel body **6**
- Straight-through valve,
aluminum body **7**
- Straight-through valve,
stainless steel body **8**

Materials Used

	Aluminum version	Stainless steel version
Housing	Aluminum (AlMgSi) EN-AW 6060 ¹⁾	Stainless steel (AISI 304)
Inner section ¹⁾	Aluminum (AlMgSi)	Stainless steel (AISI 304)
Drive unit ²⁾	Aluminum	Aluminum
Valve disk	AISI 316L	AISI 316L
Bellows	AISI 316	AISI 316
Head and disk O-ring	Viton	Viton
Rotary knob	Plastic	Plastic
Position indicating cover ²⁾	Plastic	Plastic
Housing cover ¹⁾	Plastic	Plastic

¹⁾ For the solenoid version only

²⁾ For pneumatic and electropneumatic version only

Right-Angle Valves, Bellows-Sealed, Manually Operated

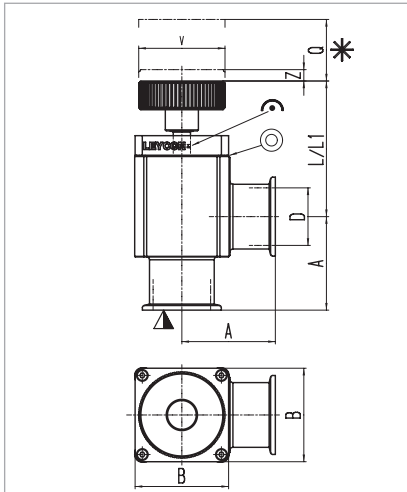

Dimensional drawing for the manually operated, bellows-sealed, right-angle valves

Dimension Table

DN	ISO-KF	16	25	40	50
A	mm	40	50	65	70
B	mm	40	48	65	77
D	mm	16	25	40	50
L ¹⁾	mm	64.9	60.9	94.3	101.1
L1 ²⁾	mm	67.4	64.3	97.3	104.1
Q	mm	46	44	73.5	85.5
V	mm	40	40	60	60
Z ³⁾	mm	3.6	4.7	7.9	9.3

¹⁾ Aluminum version

²⁾ Stainless steel version

³⁾ Disk stroke is greater due to the transmission

Advantages to the User

Valves with Rotary Knob

- Allow also for reduced venting of systems
- Suited as a manually operated variable leak valve to roughly control gas flows
- Leak tight in both directions up to a pressure of 2.0 bar and easy to open
- Installation in any orientation

Connection Icons

- ▼ Side of the valve seat
- * Required clearance
- ⦿ Mechanical position indicator
- ⊗ Leak detection bore

Technical Data

DN 16 ISO-KF

DN 25 ISO-KF

DN 40 ISO-KF

DN 50 ISO-KF

		Aluminum	Stainl. Steel	Aluminum	Stainl. Steel	Aluminum	Stainl. Steel	Aluminum	Stainl. Steel
Service life	Cycles	30,000							
Conductance at molecular flow	l/s	5	5	14	14	45	45	50	50
Leak rate	mbar x l/s	1 x 10 ⁻⁹							
Operating pressure range	mbar	10 ⁻⁸ – 5000							
Differential pressure, closing and opening direction	bar	5 / 2							
Ambient / operating temperature, max.	°C	80							
Seal		FPM (FKM)							
Weight	kg	0.3	0.3	0.4	0.5	1.0	1.1	1.4	1.5

Ordering Information

DN 16 ISO-KF

DN 25 ISO-KF

DN 40 ISO-KF

DN 50 ISO-KF

	Aluminum	Stainl. Steel	Aluminum	Stainl. Steel	Aluminum	Stainl. Steel	Aluminum	Stainl. Steel
	Part No.	Part No.	Part No.	Part No.	Part No.	Part No.	Part No.	Part No.
Right-angle valve, rotary knob								
BAV ... M AL	215 375	-	215 376	-	215 377	-	215 378	-
BAV ... M AL EPDM	215 384							
	V001	-	-	-	-	-	-	-
BAV ... M SS	-	215 383	-	215 385	-	215 386	-	215 387
Spare parts								
Bellows feedthrough	E 242 292		E 233 014		E 229 542		E 244 980	
Knob	E 245 912				E 245 913			
Seal kit consisting of disk seal (O-ring) and head seal (O-ring)	EK 242 324		EK 241 077		EK 241 079		EK 245 556	

Straight-Through Valves, Bellows-Sealed, Manually Operated

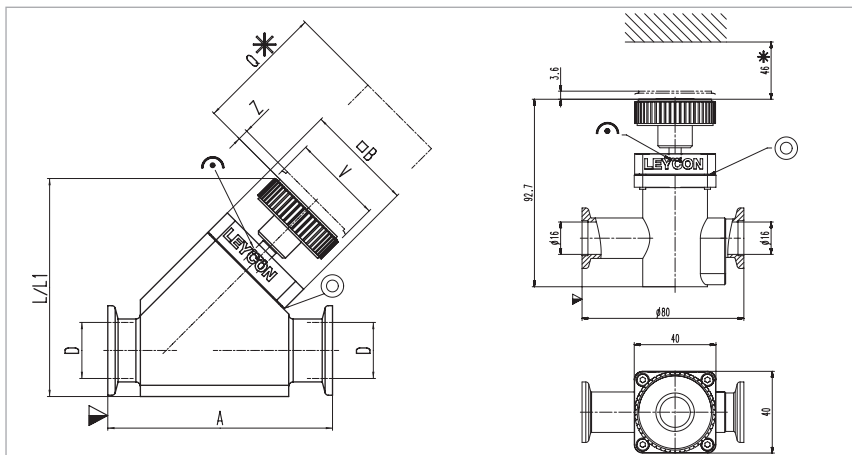

Dimensional drawing for the manually operated, bellows-sealed straight-through valves; right DN 16 ISO-KF

Dimension Table

DN	ISO-KF	16	25	40	50
A	mm	80	100	130	178
B	mm	40	48	65	77
D	mm	16	25	40	50
L ¹⁾	mm	90.6	97	143.5	167.2
L1 ²⁾	mm	92.8	105.8	152.5	172.1
Q	mm	46	44	73.5	85.5
V	mm	40	40	60	60
Z ³⁾	mm	3.6	4.7	7.9	9.3

¹⁾ Aluminum version

²⁾ Stainless steel version

³⁾ Disk stroke is greater due to the transmission

Advantages to the User

Valves with Rotary Knob

- Allow also for reduced venting of systems
- Suited as a manually operated variable leak valve to roughly control gas flows

- Leak tight in both directions up to a pressure of 2.0 bar and easy to open
- Installation in any orientation

Connection Icons

- ▽ Side of the valve seat
- * Required clearance
- ⊕ Mechanical position indicator
- ⊙ Leak detection bore

Technical Data

DN 16 ISO-KF

DN 25 ISO-KF

DN 40 ISO-KF

DN 50 ISO-KF

		Aluminum	Stainl. Steel	Aluminum	Stainl. Steel	Aluminum	Stainl. Steel	Aluminum
Service life	Cycles	30,000						
Conductance at molecular flow	l/s	5	5	14	14	45	45	50
Leak rate	mbar x l/s	1 x 10 ⁻⁹						
Operating pressure range	mbar	10 ⁻⁸ – 5000						
Differential pressure, closing and opening direction	bar	5 / 2						
Ambient / operating temperature, max.	°C	80						
Seal		FPM (FKM)						
Weight	kg	0.4	0.8	0.5	0.5	1.3	1.2	2.2

Ordering Information

DN 16 ISO-KF

DN 25 ISO-KF

DN 40 ISO-KF

DN 50 ISO-KF

	Aluminum	Stainl. Steel	Aluminum	Stainl. Steel	Aluminum	Stainl. Steel	Stainl. Steel
	Part No.	Part No.	Part No.	Part No.	Part No.	Part No.	Part No.
Straight-through valve, rotary knob							
BAV ... M AL	215 313	-	215 388	-	215 389	-	215 390
BAV ... M SS	-	215 379	-	215 374	-	215 381	-
Spare parts							
Bellows feedthrough	E 242 292		E 233 014		E 229 542		E 244 980
Knob	E 245 912				E 245 913		
Seal kit consisting of disk seal (O-ring) and head seal (O-ring)	EK 242 324		EK 241 077		EK 241 079		EK 245 556

Right-Angle Valves, Bellows-Sealed, (Electro)pneumatically Operated

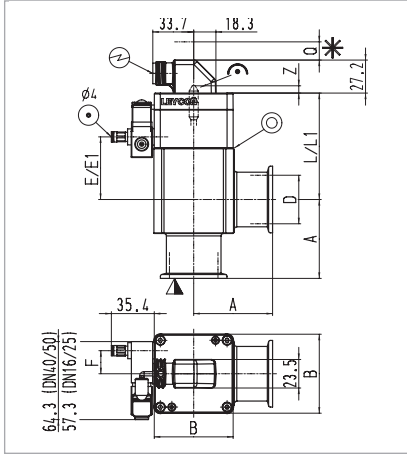

Dimensional drawing right-angle valves,
with fitted pilot valve

Dimension Table

DN	ISO-KF	16	25	40	50
A	mm	40	50	65	70
B	mm	40	48	65	77
D	mm	16	25	40	50
L ¹⁾	mm	65.2	60.6	87.7	96
L1 ²⁾	mm	67.7	64	90.7	99
Q	mm	46	44	73.5	85.5
F	mm	9	13	19	20
Z	mm	2	4	9.5	10
E ¹⁾	mm	35.6	30.6	51.6	58.4
E1 ²⁾	mm	38.1	34	54.6	61.4

¹⁾ Aluminum version

²⁾ Stainless steel version

Connection Icons

- ▼ Side of the valve seat
- * Required clearance
- ☉ Mechanical position indicator
- ⊖ Leak detection bore
- ⊙ Electrical connection
- ⊕ Compressed air connection

Advantages to the User

- Quiet opening and closing action with very little vibration
- Short opening and closing times
- Optical valve position indicator as standard
- Very low leak rate and insensitive to particles owing to bellows seal. Always closed in case the compressed air supply fails
- Electric position indicator is standard
- With and without pilot valve as standard
- Standard electrical and compressed air connections
- Protection class IP 50
- The valves are closed by the restoring force of a spring
- Installation in any orientation and no restrictions as to the direction of flow

Technical Data

		DN 16 ISO-KF		DN 25 ISO-KF		DN 40 ISO-KF		DN 50 ISO-KF	
		Aluminum	Stainl. Steel	Aluminum	Stainl. Steel	Aluminum	Stainl. Steel	Aluminum	Stainl. Steel
Service life	cycles	10 millions							
Conductance at molecular flow	l/s	5	5	14	14	45	45	80	80
Leak rate	mbar x l/s	1 x 10 ⁻⁹							
Operating pressure range	mbar	10 ⁻⁸ – 5000							
Differential pressure, closing and opening direction	bar	5 / 2							
Ambient / operating temperature, max.	°C	80							
Seal		FPM							
Closing time / opening time	ms	100 / 100	100 / 100	210 / 120	210 / 120	550 / 250	550 / 250	650 / 400	650 / 400
Switching frequency	1/min	100							
Position indicator, switching capacity									
Voltage	V AC / V DC	≤ 50							
Current	mA	5 – 100							
Power	W	≤ 1,0							
Control valve	V DC / W	24 / 2.5							
Compressed air, overpressure	bar	4 to 8							
Air cylinder, volume	l	0.004	0.004	0.011	0.011	0.035	0.035	0.047	0.047
Compressed air connection	mm	4 and 6							
Weight, with pilot valve	kg	0.3	0.3	0.4	0.5	1.0	1.1	1.4	1.5

Ordering Information

	DN 16 ISO-KF		DN 25 ISO-KF		DN 40 ISO-KF		DN 50 ISO-KF	
	Aluminum	Stainl. Steel	Aluminum	Stainl. Steel	Aluminum	Stainl. Steel	Aluminum	Stainl. Steel
	Part No.	Part No.	Part No.	Part No.	Part No.	Part No.	Part No.	Part No.
Right-angle valves, bellows sealed								
BAV ... P AL	215 315	-	215 316	-	215 317	-	215 318	-
BAV ... P SS	-	215 335	-	215 336	-	215 337	-	215 338
BAV ... EP AL 24 V AC	215 319	-	215 320	-	215 321	-	215 322	-
BAV ... EP SS 24 V AC	-	215 339	-	215 340	-	215 341	-	215 342
BAV ... EP AL 24 V DC	215 323	-	215 324	-	215 325	-	215 326	-
BAV ... EP AL 24 V DC, normally open	215 395 V01	-	215 394 V01	-	215 130	-	-	-
BAV ... EP SS 24 V DC	-	215 347	-	215 348	-	215 349	-	215 350
BAV ... EP AL 115 V AC	215 327	-	215 328	-	215 329	-	215 330	-
BAV ... EP SS 115 V AC	-	215 351	-	215 352	-	215 353	-	215 354
BAV ... EP AL 230 V AC	215 331	-	215 332	-	215 333	-	215 334	-
BAV ... EP SS 230 V AC	-	215 343	-	215 344	-	215 345	-	215 346
Spare parts								
Bellows feedthrough	E 242 292		E 233 014		E 229 542		E 244 980	
Seal kit consisting of disk seal (O-ring) and head seal (O-ring)	EK 242 324		EK 241 077		EK 241 079		EK 245 556	
Mating plug (included with the valve)	599998003							

Straight-Through Valves, Bellows-Sealed, (Electro)pneumatically Operated

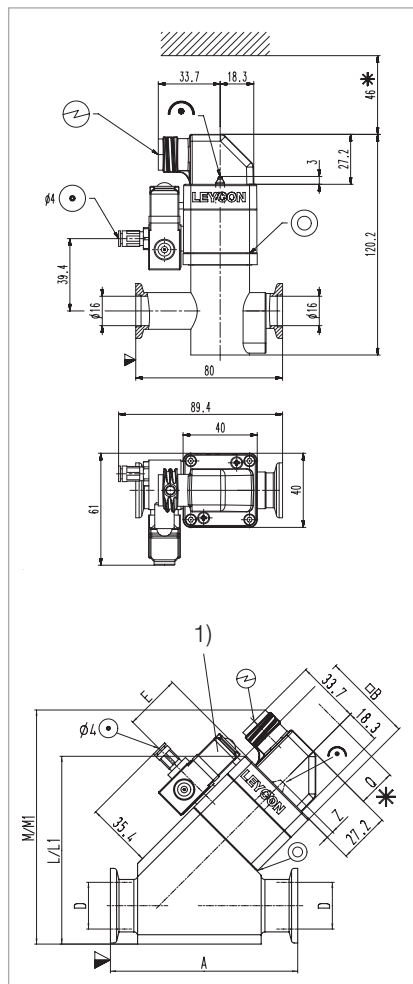

Dimensional drawing
for the straight-through valves
with fitted pilot valve (EP)
without pilot valve (P)
(on top DN 16 ISO-KF, stainless steel)
1) pilot valve

Dimension Table

DN	ISO-KF	16	25	40	50
A	mm	80	100	130	178
B	mm	40	48	65	77
D	mm	16	25	40	50
L	mm	91.5	100.3	140.9	170.1
Q	mm	46	44	73.5	85.5
E	mm	29.6	30	36.1	37.6
Z	mm	2	4	9.5	10
M	mm	120	125	160	185

Connection Icons

- ▼ Side of the valve seat
- * Required clearance
- ◐ Mechanical position indicator
- ⚡ Leak detection bore
- ⊙ Electrical connection
- ⊙ Compressed air connection

Advantages to the User

- Quiet opening and closing action with very little vibration
- Short opening and closing times
- Optical valve position indicator as standard
- Very low leak rate and insensitive to particles owing to bellows seal – thus always closed in case the compressed air supply fails
- Electric position indicator is standard
- With and without pilot valve as standard
- Protection class IP 50
- Standard electrical and compressed air connections
- The valves are closed by the restoring force of a spring

Technical Data

		DN 16 ISO-KF		DN 25 ISO-KF		DN 40 ISO-KF		DN 50 ISO-KF
		Aluminum	Stainl. Steel	Aluminum	Stainl. Steel	Aluminum	Stainl. Steel	Aluminum
Service life	cycles	10 millions						
Conductance at molecular flow	l/s	5	5	14	14	45	45	80
Leak rate	mbar x l/s	1 x 10 ⁻⁹						
Operating pressure range	mbar	10 ⁻⁸ – 5000						
Differential pressure, closing and opening direction	bar	5 / 2						
Ambient / Operating temperature, max.	°C	80						
Seal		FPM (FKM)						
Closing time / opening time	ms	100 / 100	100 / 100	210 / 120	210 / 120	550 / 250	550 / 250	650 / 400
Switching frequency	1/min	100						
Position indicator, switching capacity								
Voltage	V AC / V DC	≤ 50						
Current	mA	5 – 100						
Power	W	≤ 1,0						
Pilot valve	V DC / W	24 / 2.5						
Compressed air, overpressure	bar	4 to 8						
Air cylinder, volume	l	0.004	0.004	0.011	0.011	0.035	0.035	0.047
Compressed air connection	mm	4 and 6						
Weight, with pilot valve	kg	0.3	0.8	0.5	0.5	1.3	1.2	2.2

Ordering Information

	DN 16 ISO-KF		DN 25 ISO-KF		DN 40 ISO-KF		DN 50 ISO-KF
	Aluminum	Stainl. Steel	Aluminum	Stainl. Steel	Aluminum	Stainl. Steel	Aluminum
	Part No.	Part No.	Part No.	Part No.	Part No.	Part No.	Part No.
Straight-through valve, bellows sealed							
BIV ... P SS	-	215 355	-	215 356	-	215 357	-
BIV ... EP SS 24 V AC	-	215 359	-	215 360	-	215 361	-
BIV ... EP AL 24 V DC	215 314	-	215 391	-	215 392	-	215 393
BIV ... EP SS 24 V DC	-	215 367	-	215 368	-	215 369	-
BIV ... EP SS 115 V AC	-	215 371	-	215 372	-	215 373	-
BIV ... EP SS 230 V AC	-	215 363	-	215 364	-	215 365	-
Spare parts							
Bellows feedthrough	E 242 292		E 233 014		E 229 542		E 244 980
Seal kit consisting of	EK 242 324		EK 241 077		EK 241 079		EK 245 556
Disk seal (O-ring) and							
Head seal (O-ring)							
Mating plug	599998003						
(included with the valve)							

Right-Angle Valves, Electromagnetically Operated

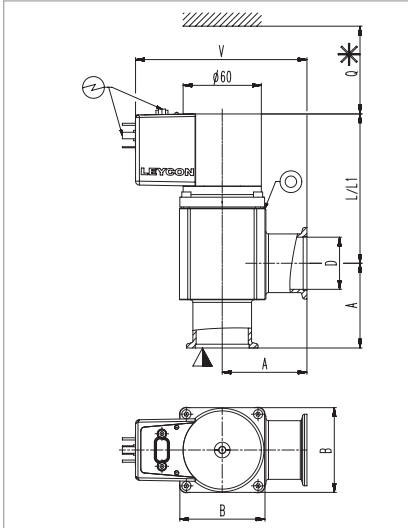





Dimensional drawing for the electromagnetically operated right-angle valves

Dimension Table

DN	ISO-KF	16	25	40
A	mm	40	50	65
B	mm	40	48	65
D	mm	16	25	40
L	mm	100	93	114
L1	mm	102.5	103.4	117
Q	mm	46	44	73.5
V	mm	106.5	116.5	131.5

Connection Icons

-  Side of the valve seat
-  Required clearance
-  Leak detection bore
-  Electrical connection

Electromagnetic valves are particularly well suited for vacuum systems in which the valves need to be remotely controlled and where compressed air is not readily available.

Advantages to the User

- Selectable operating mode:
 - Remote control via programmable control or personal computer
 - direct operation by switching the supply voltage on and off
- Well visible, unambiguous optical position indicator: open (green LED) and closed (orange LED)
- Integrated electrically floating position indicator (opto-coupler for 48 V DC)
- Optical error indicator (LEDs flash)
- Protection class IP 40
- Spring action closure, thus closed when the power fails
- Low operating temperature
- Installation in any orientation and no restrictions as to the direction of flow

Technical Data

DN 16 ISO-KF

DN 25 ISO-KF

DN 40 ISO-KF

Service life	cycles	200,000		
Conductance at molecular flow	l/s	5	14	45
Leak rate	mbar x l/s	1 x 10 ⁻⁹		
Operating pressure range	mbar	10 ⁻⁸ to 2 bar		
Differential pressure, closing and opening direction	bar	≤ 2		
Ambient / Operating temperature, max.	°C	0 to +50		
Closing time / opening time	s	0.2		
Switching frequency at ambient temperature	1/min °C	15 20		
Rating, max.	V AC/DC	48		
Rating for the valve position indicator, max.	mA	500		
Power consumption, max.				
Actuation	W	700 (~100 ms)		
Hold	W	10		
Supply voltage, max.	V AC	100 – 115 / 200 – 240		
Frequency	Hz	50/60 Hz		
Protection class	IP	40		
Weight	kg	1.3	1.5	1.8

Ordering Information

DN 16 ISO-KF

DN 25 ISO-KF

DN 40 ISO-KF

	Part No.	Part No.	Part No.
Right-angle valve, bellows-sealed, electromagnetic actuator, microprocessor controlled			
BAV ... EM AL			
100-120 V, 50/60 Hz	215 004 V02	215 064 V02	215 124 V02
200-240 V, 50/60 Hz	215 004 V01	215 064 V01	215 124 V01
BAV ... EM SS			
100-120 V, 50/60 Hz	215 006 V02	215 079 V02	215 134 V02
200-240 V, 50/60 Hz	215 006 V01	215 079 V01	215 134 V01
Spare parts			
Seal kit	EK 396 788	EK 388 499	EK 388 450

Right-Angle Valves with ISO-K Flanges

Overview

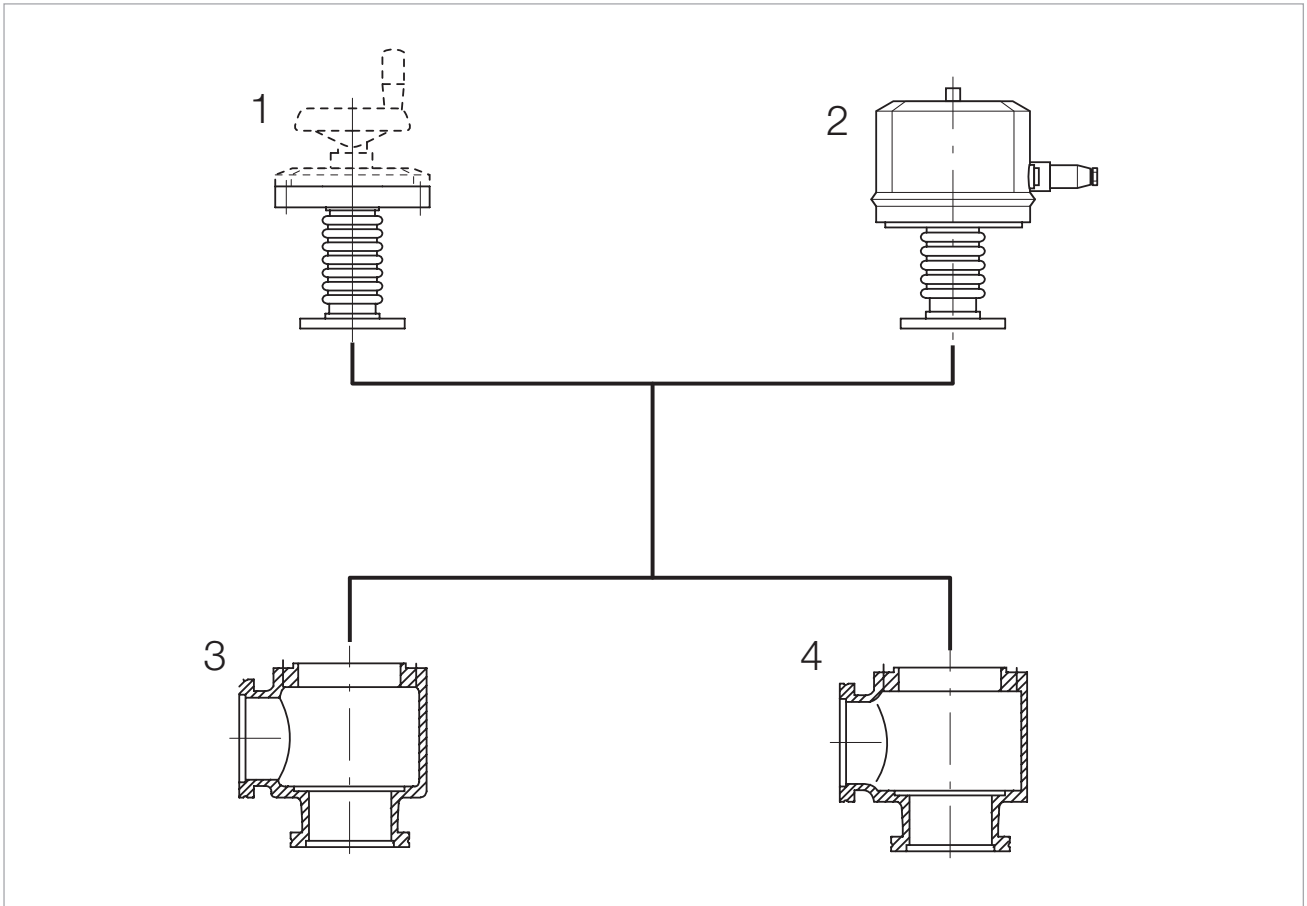

Leybold valves with ISO-K flanges are available with any of two drives and either of two bodies.

Types of drive

- Handwheel **(1)**
- Electropneumatic drive **(2)**

Body types

- Right-angle valve with aluminum body **(3)**
- Right-angle valve with stainless steel body **(4)**

Advantages to the User

- Full exchangeability of the subassemblies
- Two types of drive
- Two body options
- Standard nominal widths to DIN 28 404 and ISO 1609
- Simplified stocking of spare parts

Connection Pictograms

- Position indicator connection
- ⓘ Compressed air connection
- ⚡ Power connection
- Position indicator

Nominal widths DN 63 ISO-K and DN 100 ISO-K are available in aluminum and stainless steel, DN 160 ISO-K in aluminum only.

Nominal width DN 100 ISO-K only with pneumatic or electropneumatic drive.

Right-Angle Valves, Bellows-Sealed, Manually Operated

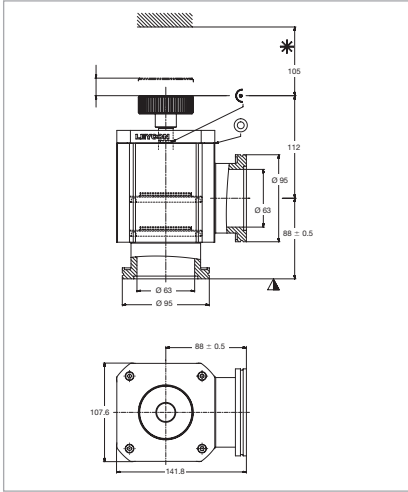

Dimensional drawing for the right-angle valves, bellows-sealed, manually operated, dimensions in mm

The universal valves are particularly well suited for systems where remote control is not mandatory. Moreover, the valves may be used for maintenance purposes in connection with backing pumps or condensate separators.

Advantages to the User

- Removable handle
- Modular design
- Rugged and compact
- Easy to clean
- Gentle venting of systems
- Seal in both directions up to a pressure difference of 1.5 bar
- Easy manual operation, for an effortless vacuum-tight seal
- May also be used as a variable leak valve to roughly control gas flows
- Installation in any orientation and no restrictions as to the direction of flow

Technical Data

DN 63 ISO-KF

Service life	cycles	3 millions
Conductance at molecular flow	l/s	160
Leak rate	mbar x l/s	1×10^{-9}
Operating pressure range	mbar	1×10^{-9} to 5000 (abs.)
Differential pressure, closing and opening direction	bar	$< 5 / < 2$
Opening against differential pressure	bar	< 1 in both directions
Ambient / Operating temperature, max.	°C	80
Seal		FPM (Viton)
Weight		
Aluminum body	kg	2.9
Stainless steel body	kg	2.8
Material		
Valve body		aluminum (AlMgSi) or stainless steel AISI 304 (1.4301, 1.4305)
Disk		stainless steel AISI 316L (1.4404, 1.4435)
Bellows		stainless steel AISI 316L (1.4404, 1.4435), 316 Ti (1.4571)

Ordering Information

DN 63 ISO-KF

	Part No.
Right-angle valve, bellows-sealed, manually operated	
Aluminum body	107 80 V01
Stainless steel body	107 83 V01

Right-Angle Valves, Bellows-Sealed, Manually Operated



These universal valves are ideal especially for smaller systems, where remote control is not essential.

They may be also installed in larger systems, where backing pumps or condensate separators or similar units are to be cut off at longer intervals for maintenance purposes by maintenance personnel.

Advantages to the User

- Gentle venting of systems
- Seal in both directions up to a pressure difference of 1.5 bar
- Easy manual operation, for an effortless vacuum-tight seal
- May also be used as a variable leak valve to roughly control gas flows
- Installation in any orientation and no restrictions as to the direction of flow

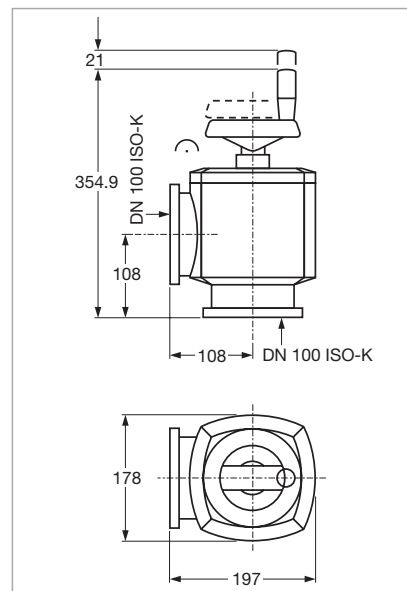

Dimensional drawing (all dimensions in mm)

Technical Data

DN 100 ISO-KF

Service life	cycles	10,000
Conductance at molecular flow	l/s	440
Leak rate	mbar x l/s	1×10^{-9}
Operating pressure range	mbar	1×10^{-8} to 2000
Differential pressure, closing and opening direction	bar	opening direction $\leq 1,2$ closing direction ≤ 2
Opening against differential pressure at the valve disk	bar	< 1
Ambient / Operating temperature, max.	°C	80
Seal		FPM (Viton)
Weight		
Aluminum body	kg	6.0
Stainless steel body	kg	6.5
Material		
Valve body		aluminum EN AL 42000 or stainless steel (1.4404)
Drive		aluminum
Disk		stainless steel (1.4404)
Bellows		stainless steel (1.4571)
Handwheel		plastic

Ordering Information

DN 100 ISO-KF

	Part No.
Right-angle valve, bellows-sealed, manually operated	
Aluminum body	107 81 V01
Stainless steel body	107 84 V01

Right-Angle Valves, Bellows-Sealed, Electropneumatically Operated



Electropneumatically actuated right-angle valves, bellows sealed, stainless steel, DN 100 ISO-K (left), aluminum DN 160 ISO-K (right)

Electropneumatically actuated right-angle valves are used in automated vacuum systems which need to be controlled electrically.

Advantages to the User

- Pneumatic or electropneumatic opening
- Short opening and closing times
- Optical position indicator
- Electric position indicator
- With and without pilot valve IP 54
- Protection class IP 50
- The valves are closed by the restoring force of a spring
- Installation in any orientation and no restrictions as to the direction of flow

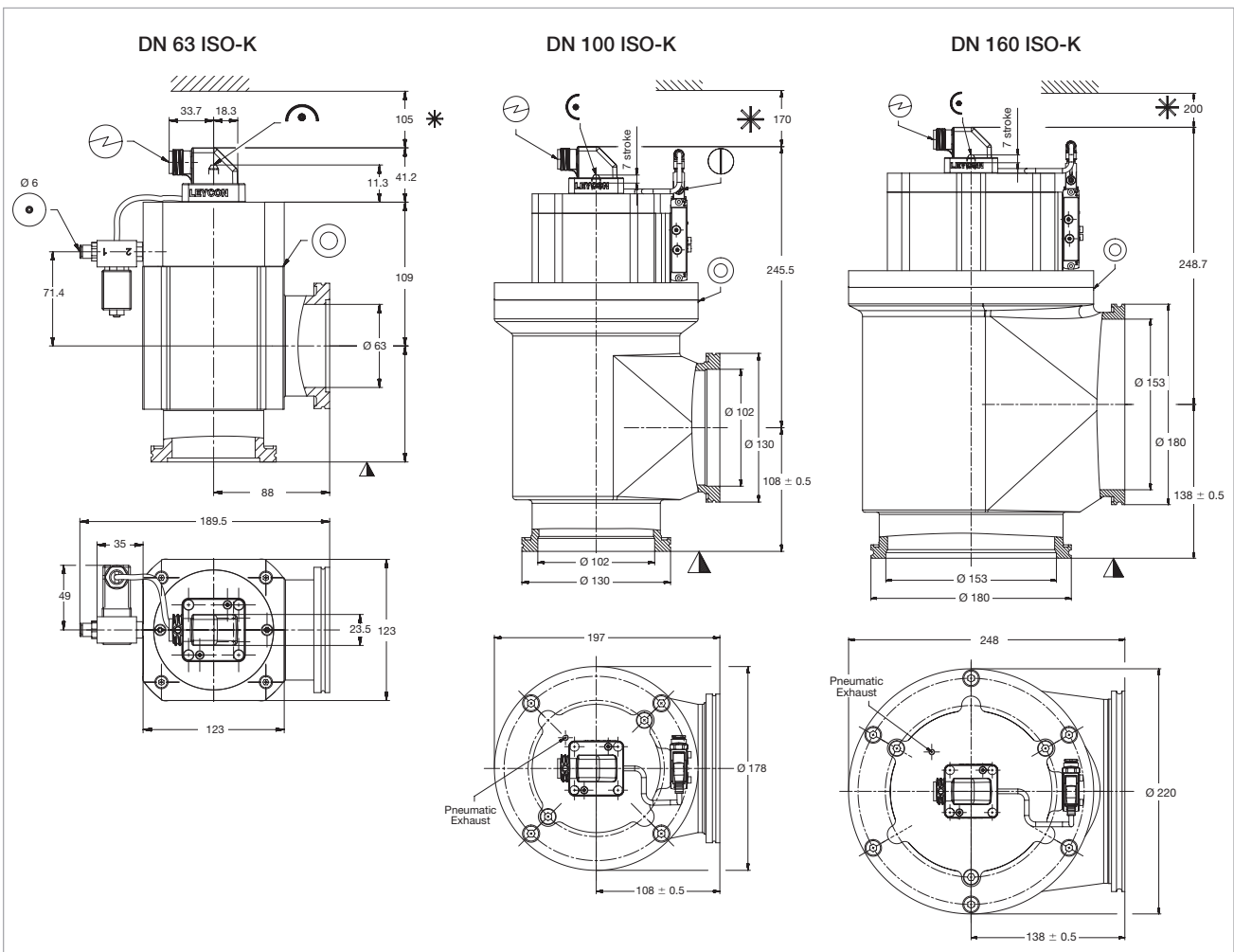

Dimensional drawing (all dimensions in mm)

Technical Data

DN 63 ISO-K

DN 100 ISO-K

DN 160 ISO-K

Service life	cycles	1 million		
Conductance at molecular flow	l/s	160	440	1000
Leak rate	mbar x l/s	1 x 10 ⁻⁹		
Operating pressure range	mbar	1 x 10 ⁻⁸ to 5000 (abs.)	1 x 10 ⁻⁸ to 2000 (abs.)	1 x 10 ⁻⁸ to 2000 (abs.)
Differential pressure, closing and opening direction	bar	≤ 4 / ≤ 1,2	≤ 2 / ≤ 1,2	≤ 2 / ≤ 1,2
Opening against differential pressure at the valve disk	bar	≤ 1		
Ambient / operating temperature, max.	°C	80		
Seal		FKM (Viton)		
Closing time / opening time	s	≤ 1	≤ 1	≤ 1,5
Switching frequency	1/min	≤ 30	≤ 30	≤ 20
Position indicator, rating	V AC/DC mA	≤ 50 5 to 100		
Compressed air, overpressure	bar	4 to 8	4,5 to 7	4,5 to 7
Compressed air volume	cm ³	112	330	650
Compressed air connection	mm	6		
Weight				
Aluminum housing	kg	3.9	9	14
Stainless steel housing	kg	3.7	9	-

Ordering Information

DN 63 ISO-K

DN 100 ISO-K

DN 160 ISO-K

	Part No.	Part No.	Part No.
Right-angle valve, bellows-sealed, electropneumatic drive without Pilot valve			
Aluminum housing	107 90 V01	107 91 V01	107 92 V01
Stainless steel body	107 93 V01	107 94 V01	-
Valve with Pilot valve 24 V DC			
Aluminum housing	108 00 V01	108 01 V01	108 02 V01
Stainless steel body	108 10 V01	108 11 V01	-
Valve with Pilot valve 24 V AC			
Aluminum housing	108 03 V01	108 04 V01	108 05 V01
Stainless steel body	108 13 V01	-	-
Valve with Pilot valve 100 – 115 V AC			
Aluminum housing	108 20 V01	108 21 V01	108 22 V01
Stainless steel body	-	-	-
Valve with Pilot valve 200 – 240 V AC			
Aluminum housing	108 25 V01	108 26 V01	108 27 V01
Stainless steel body	108 35 V01	108 36 V01	-
Mating plug (included with the valve)	599998003		

Special Valves with ISO-KF/ISO-K/CF Flange

Overview



Leybold offers a range of special valves for a variety of different applications and to meet special design requirements of customers.

Among these are:

- SECUVAC vacuum safety valves (DN 16 ISO-KF to DN 100 ISO-K) **1**
- Venting Valves **2**

- Power failure venting valves **3**
- Vacuum Locks **4**
- Sealing Valves **4**
- Variable leak valves **5**
- Ball Valves **6**

These valves ideally supplement our range of ISO-KF and ISO-K valves.

SECUVAC Vacuum Safety Valves

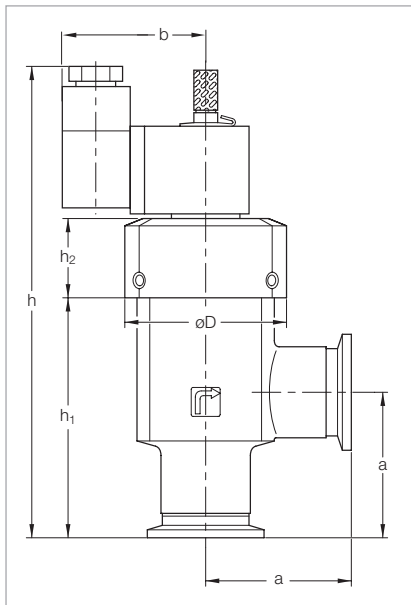

Dimensional drawing for the SECUVAC valves with ISO-KF small flanges

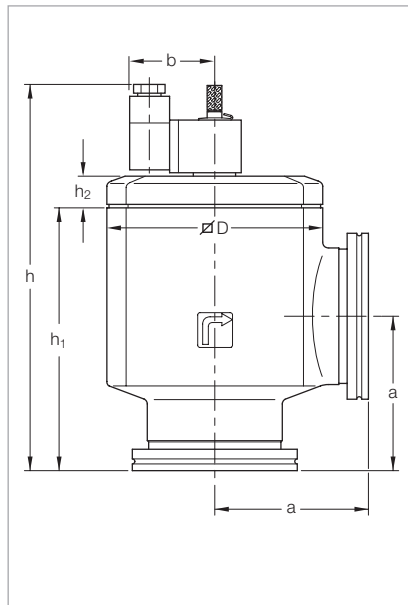

Dimensional drawing for the SECUVAC valves with ISO-K clamp flanges

These solenoid right-angle valves were specially developed for use with rotary vacuum pumps which are not equipped with a built-in anti-suckback valve. The SECUVAC safety valve protects the vacuum system against unplanned venting via the backing pump in case of a power failure and it ensures that the vacuum system remains sealed until the backing pump, after it has restarted, has evacuated the connecting lines.

Dimension Table Special Valves (ISO-KF)

DN	ISO-KF	16	25	40
a	mm	40	50	65
b	mm	49	49	49
D	mm	44	56	82
h	mm	138.6	161.8	177.8
h ₁	mm	62.3	82.5	101.7
h ₂	mm	24	27	24,3

Dimension Table Special Valves (ISO-K)

DN	ISO-K	63	100
a	mm	88	108
b	mm	49	49
D	mm	124	164
h	mm	220.5	263.5
h ₁	mm	150	175
h ₂	mm	18.2	36.2

Advantages to the User

Two valve functions in one:

- Fast-closing high vacuum isolation valve for separating the vacuum chamber or a vapor jet pump (a diffusion pump, for example) from the backing pump
- Venting valve for venting of the valve's chamber and thus the pump (backing pump)
- Immediate closing action upon power failure
- Opening action only after the in-take line has been evacuated
- Delayed isolation of the vacuum chamber and venting the vacuum pump (negligible "gulp")

Typical Applications

- Safety isolation valve between backing pump and vacuum chamber or vapor jet pumps (protection of the vacuum chamber against venting in the event of a power failure)

Technical Data**SECUVAC Valve**

		DN 16 ISO-KF	DN 25 ISO-KF	DN 40 ISO-KF
Conductance at molecular flow	l/s	3.8	11	30.5
Current consumption DC	W	2.5		
Actuation / holding AC	VA	5 / 3.7		
Leak tightness, body	mbar x l/s	< 1 x 10 ⁻⁹		
Leak tightness, valve disk	mbar x l/s	< 1 x 10 ⁻⁵		
Installation orientation		any		
Operating pressure range	mbar	1 x 10 ⁻⁸ to 1000		
Differential pressure for opening	mbar	150		
for closing	mbar	150		
Opening time	s	< 15		
Closing time / reaction time	ms	< 100 / < 50		
Ambient temperature	°C	+5 to +50		
Protection	IP	65		
Weight	kg	0.3	0.5	0.9
Material Body		aluminum		
Seal		FPM (FKM)		

Technical Data**SECUVAC Valve**

		DN 63 ISO-K	DN 100 ISO-K
Conductance at molecular flow	l/s	126	300
Current consumption DC	W	2.5	
Actuation / holding AC	VA	5 / 3.7	
Leak tightness, body	mbar x l/s	< 1 x 10 ⁻⁹	
Leak tightness, valve disk	mbar x l/s	< 1 x 10 ⁻⁵	
Installation orientation		any	
Operating pressure range	mbar	1 · x 10 ⁻⁸ to 1000	
Differential pressure for opening	mbar	150	
for closing	mbar	150	
Opening time	s	< 30	
Closing time / reaction time	ms	< 100 / < 50	
Ambient temperature	°C	+5 to +50	
Protection	IP	65	
Weight	kg	2.4	5.1
Material Body		aluminum	
Seal		FPM (FKM)	

Ordering Information

SECUVAC Valve

	DN 16 ISO-KF	DN 25 ISO-KF	DN 40 ISO-KF
	Part No.	Part No.	Part No.
SECUVAC valve			
24 V DC	215 015	215 065	215 135
100 – 115 V AC	215 016	215 066	215 136
200 – 230 V AC	215 017	215 067	215 137
Spare parts			
Seal kit	E 105 02	E 105 04	E 105 05
Solenoid coils for SECUVAC valves and power failure venting valves			
24 V DC		E 215 242	
100 – 115 V AC / 50/60 Hz		E 215 241	
200 – 230 V AC / 50/60 Hz		E 215 240	
Filter for SECUVAC valves and power failure venting valves (set of 5 pcs.)		215 701	

Ordering Information

SECUVAC Valve

	DN 63 ISO-K	DN 100 ISO-K
	Part No.	Part No.
SECUVAC valve		
24 V DC	215 205	215 225
100 – 115 V AC	215 206	-
200 – 230 V AC	215 207	215 227
Spare parts		
Seal kit	E 105 07	E 105 08
Solenoid coils for SECUVAC valves and power failure venting valves		
24 V DC		E 215 242
100 – 115 V AC / 50/60 Hz		E 215 241
200 – 230 V AC / 50/60 Hz		E 215 240
Filter for SECUVAC valves and power failure venting valves (set of 5 pcs.)		215 701

Interference Suppression Kit – Illuminated

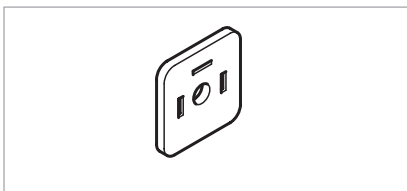

As an option for the solenoid coil, an interference suppression kit is offered which reliably prevents any interferences from affecting other equipment operating in the vicinity.

Ordering Information

Interference Suppression Kit

	Part No.
Interference suppression kit	
24 V DC	104 96

Pressure Relief Valve

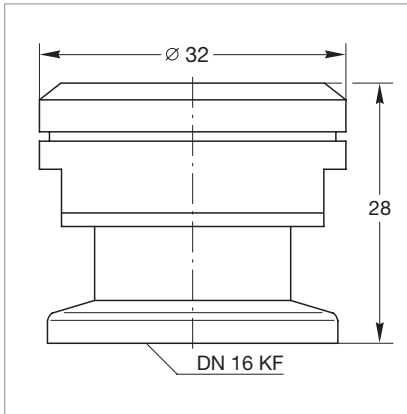

Dimensional drawing for the pressure relief valve

Typical Applications

- Protecting sealed vacuum systems like cryopumps, cryostats, lifting devices, for example against internal overpressures
- Mandatory for systems which are separated when cold, as a means of protection against overpressures

Technical Data

Pressure Relief Valve

Responding pressure	mbar	1150 ±40
Flow at 140 mbar	l x h ⁻¹	500
Valve disk		Spring loaded, with O-ring seal
Leak rate in the closed state	mbar x l/s (Torr x l/s)	< 1 x 10 ⁻⁸ (< 0.75 x 10 ⁻⁸)
Connection	DN	16 ISO-KF
Diameter	mm	32
Overall height	mm	28
Weight	kg	0.3

Ordering Information

Pressure Relief Valve

	Part No.
Pressure Relief Valve on DN 16 ISO-KF flange	890 39

Power Failure Venting Valves, Electromagnetically Actuated

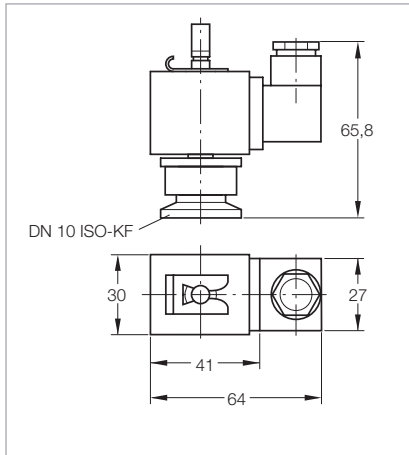

Dimensional drawing for the power failure venting valve

Power failure venting valves are open when de-energized and are used to automatically vent pumps, systems or vacuum vessels in the event of a power failure.

Permissible pressure difference < 2.5 bar (0 bar on the vacuum side).

Advantages to the User

- Can be installed in any orientation
- Protection against being contaminated by filtering of the inflowing air
- Easy to install
- Simple filter exchange

Technical Data

Power Failure Venting Valves electromagnetically actuated

Leak tightness	mbar x l/s	< 1 x 10 ⁻⁷
Venting time for a 50 l vessel	s	270
Opening time / closing time ¹⁾	ms	30 / 30
Protection class to DIN 40 050	IP	65
Permissible ambient temperature	°C	50
Weight	kg	0.1
Dimensions (W x H x D)	mm	64 x 66 x 30
Material		
Body		aluminum
Seal		NBR
Armature		brass
Filter		bronze

Ordering Information

Power Failure Venting Valves electromagnetically actuated

	Part No.
Power failure venting valve DN 10 ISO-KF, electromagnetically actuated, with inlet filter	
230 V / 50/60 Hz	174 26
24 V DC	174 46
Centering ring DN 10 ISO-KF with sinter filter	883 50
Spare solenoid valves	see SECUVAC Valves
Filter for SECUVAC valves and power failure venting valves (set of 5 pcs.)	215 701

¹⁾ At a differential pressure $V_p = 0$ bar

Variable Leak Valve with Isolation Valve

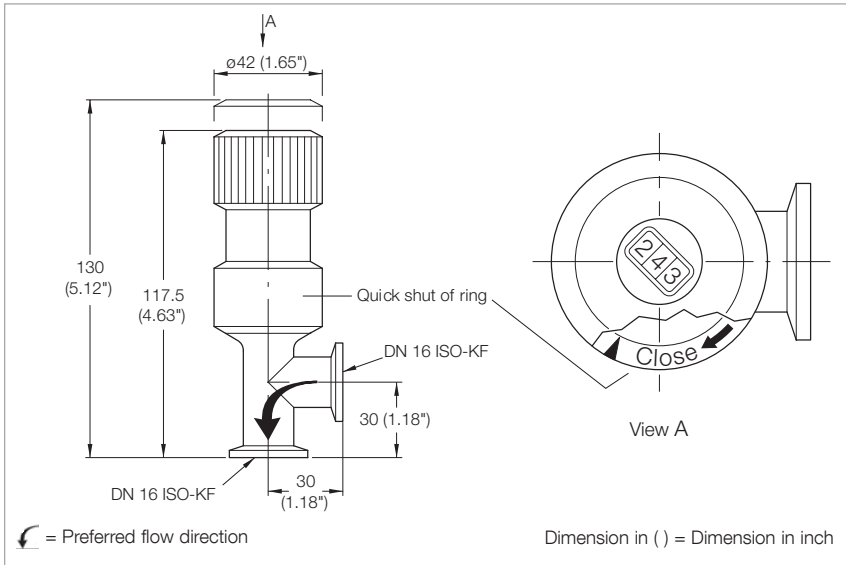

Dimensional drawing for the variable leak valve with isolation valve

Variable leak valves with a isolation valve permit an interruption of the gas supply without changing the gas admission rate setting.

Applications

- Gas admission rates of 1000 to 5×10^{-6} mbar x l/s allow variable leak valves to be used in almost all applications
- Through the digital display, the opening point may be accurately set at any time or a certain gas flow may be defined
- Blocking valve

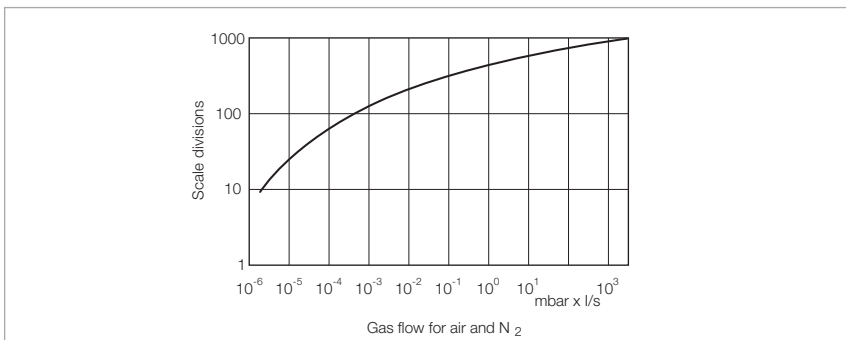

Variable leak characteristic for the variable leak valve with isolation valve

Technical Data

Variable Leak Valve with Isolation Valve

Gas flow controllable	mbar x l/s	$5 \times 10^{-6} - 1000$
Tightness	mbar x l/s	1×10^{-9}
Differential pressure	bar	2.5
Dead volume	cm ³	0.032
Operating temperature	°C	80
Bakeout temperature, flanges	°C	150
Material (housing, needle, filter)		stainless steel
Material (needle sleeve)		fluorplastomer
Seal		FPM (FKM)
Weight	kg	0.4

Ordering Information

Variable Leak Valve with Isolation Valve

	Part No.
Variable leak valve with isolation valve, DN 16 ISO-KF	215 010

Venting Valves, Manually Operated

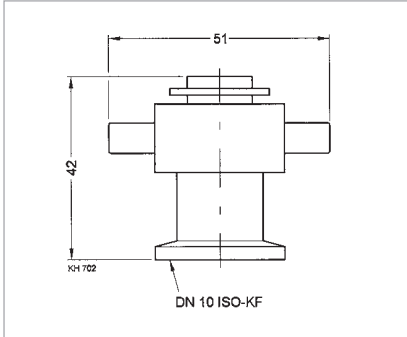

Venting valves are used to vent small vacuum systems.

Advantages to the User

- Simple opening and closing of the valve by loosening or tightening the screw cap

Dimensional drawing for the venting valve, manually operated

Technical Data

Venting Valve manually operated

Tightness	mbar x l/s	< 1 x 10 ⁻⁹
Weight	kg	0.15
Dimensions (W x H x D)	mm	51 x 42 x 30
Material		
Body		aluminum (3.0615), stainless steel (1.4301)
Inside section		aluminum (3.0615), stainless steel (1.4301)
Seal		FPM (FKM)
Screw cap		brass (nickel-plated)

Ordering Information

Venting Valve manually operated

	Part No.
Venting valve DN 10 ISO-KF, manually operated (screw cap)	
Aluminum	173 24
Stainless steel	173 37

Venting Valves, Electromagnetically Actuated

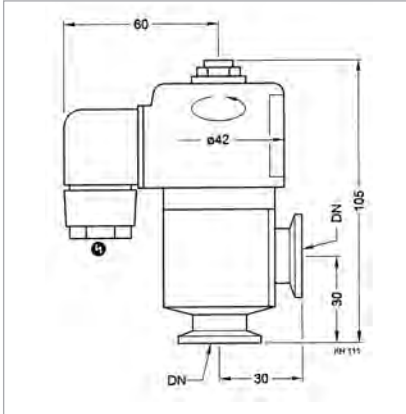

Dimensional drawing for the venting valve,
electromagnetically actuated

Venting valves are used to vent small vacuum systems and are closed when no power is applied.

Advantages to the User

- Open when power is applied, closed with no power
- Seals on one side against atmospheric pressure
- Protected against dirt by a filter

Technical Data

Venting Valve electromagnetically actuated

Leak rate	mbar x l/s	$< 1 \times 10^{-9}$
Venting time for a 100 l chamber	s	23
Mains connection	V / Hz	230 / 50/60
	V / Hz	115 / 50/60
	V DC	24
Power consumption, actuation / holding	V	35 / 15
Differential pressure in closing / opening direction	bar	5 / 1
Can be opened to a pressure difference of	bar	2
Service life	cycles	1.5 mio.
Switching frequency	1/min	50
Opening / closing time	ms	60 / 45
Conductance for molecular flow	l/s	1
Weight	kg	0.46
Dimensions (W x H x D)	mm	105 x 120 x 42
Material		
Valve body		aluminum
Seal		FPM (FKM)

Ordering Information

Venting Valve electromagnetically actuated

	Part No.
Venting valve DN 10 ISO-KF, electromagnetically actuated	
24 V DC	215 021
115 V AC	215 023
230 V AC	215 024
Centering ring with sintered metal filter, DN 10 ISO-KF	883 50

Vacuum Locks and Sealing Valves

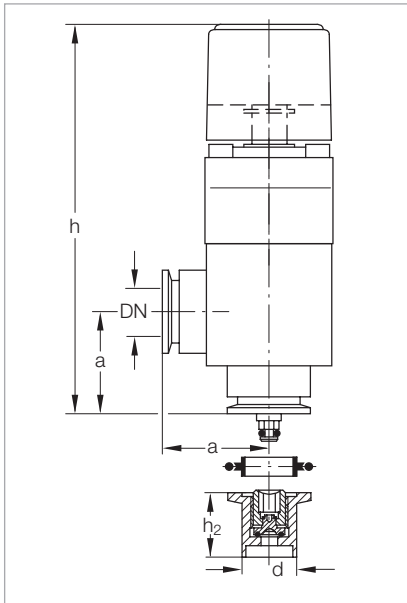

Dimensional drawing for the sealing valves

Dimension Table

DN	ISO-KF	16	25	40
a	mm	40	50	65
d	mm	16	25	38
h	mm	124	160	190
h ₂	mm	30	30	40

A screw-in sealing element with a hex. socket into which the spindle of the gas lock is inserted for actuation has been integrated within the tubulation.

After having filled in the gas or evacuated the chamber, the gas lock is detached from the small flange and may thus be reused for an unlimited number of times on other sealing valves.

Advantages to the User

- Simple to use, handy knob
- Compact, low weight
- Also well-suited for operating older types of sealing valves from Leybold
- Long travel and high conductance, thus short pumpdown times
- Spindle can be arrested in its end position
- Double O-ring seal offering a very low leak rate ($< 1 \times 10^{-7}$ mbar x l/s) and a long service life

- May be used in the entire rough and medium vacuum range
- Long service life
- Secured against inadvertent opening
- Temperature resistant

Vacuum lock	60 °C
Blocking valve	100 °C
- May be protected by a standard blank flange against becoming dirty

Typical Applications

- Sealing of evacuated or gas-filled chambers
- Post-evacuation of vessels
- Topping up and exchanging the gas filling in vessels
- Sealing valves with stainless steel ISO-KF connection and stainless steel tubulation for welding to the chamber

Technical Data

Vacuum Lock / Sealing Valve

DN 16 ISO-KF

DN 25 ISO-KF

DN 40 ISO-KF

Leak rate				
Sealing valve	mbar x l/s		1 x 10 ⁻⁷	
Vacuum lock	mbar x l/s		1 x 10 ⁻⁹	
Travel for the vacuum lock	mm	56	76	108
Free passage in the sealing valve	mm	3	8	18
Absolute pressure	bar		2.5	
Weight				
Vacuum lock	kg	0.35	1.0	1.8
Sealing valve	kg	0.04	0.1	0.12
Material				
Vacuum lock			aluminum	
Seal			FPM (FKM)	

Ordering Information

Vacuum Lock / Sealing Valve

DN 16 ISO-KF

DN 25 ISO-KF

DN 40 ISO-KF

	Part No.	Part No.	Part No.
Vacuum lock, aluminum body	283 25	283 26	283 27
Sealing valve with tubulation, stainless steel body	283 21	283 22	283 23
Clamping ring	183 41	183 42	183 43
Centering ring	883 46	883 47	883 48
Repair kit			
Vacuum lock	EK 215 055	EK 215 056	EK 215 057

Ball Valves

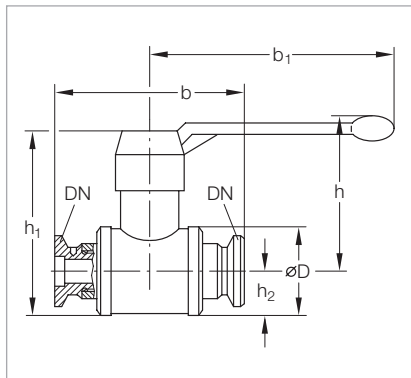

Dimensional drawing for the ball valves

Dimension Table

DN	ISO-KF	10	16	25	40
b	mm	75	100	130	160
b ₁	mm	80	80	110	138
h	mm	55	55	62	90
h ₁	mm	55	58	80	110
h ₂	mm	15	15	20	27.5
D	mm	26	30	42	60

Ball valves are rugged and cost-effective straight-through valves of small size, which are opened or closed simply by operating a lever. The valve position (OPEN/CLOSED) can be determined from the lever's position. The lever may be detached.

Ball valves are provided with lubricated gaskets and when open they permit an unobstructed passage.

Advantages to the User

- Leak tight on both sides against the atmosphere; can be opened against atmospheric pressure

Technical Data

Ball Valve

DN 10 ISO-KF DN 16 ISO-KF DN 25 ISO-KF DN 40 ISO-KF

Leak rate	mbar x l/s	< 1 x 10 ⁻⁶			
Conductance at molecular flow	l/s	1,5	3	9	30
Pressure absolute, min. / max.	mbar / bar	10 ⁻⁵ / 5			
Weight	kg	0.35	0.4	0.75	2.6
Material		brass (nickel-plated)			
Body		PTFE			
Seal		brass (hardchromium-plated)			
Ball		aluminum (3.0615)			
ISO-KF flanges					

Ordering Information

Ball Valve

DN 10 ISO-KF DN 16 ISO-KF DN 25 ISO-KF DN 40 ISO-KF

	Part No.	Part No.	Part No.	Part No.
Ball valve				
Brass body (nickel-plated)	174 94	174 95	174 96	174 97

Accessories for the Electropneumatically Operated Valves

Pilot Valves

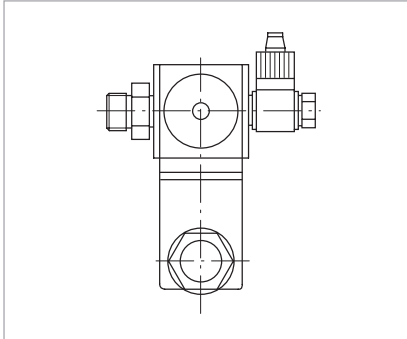

Pilot valve

A range of pilot valves is available for actuation of the electropneumatic ISO-KF valves, which cover all commonly used control voltages.

Advantages to the User

- Easy to fit to the pneumatic cylinder, adaptor is included with the DOT valve

Supplied Equipment

- Hose connection and gasket for connection to the compressed air supply

Ordering Information

ISO-KF Pilot Valves for DOT Valves (incl. Solenoid Coil)

	Part No.
110 – 120 V AC / 50/60 Hz (normally closed)	E 280 72
24 V DC (normally closed)	E 280 74

Interference Suppression Kit – Illuminated

As an option for the solenoid coil and the pilot valves an interference suppression kit is offered so as to reliably prevent any pick-up of interference by sensitive equipment in the vicinity of the solenoid coils.

Ordering Information

Interference Suppression Kit for different voltages

	Part No.
Interference Suppression Kit 110 V AC	upon request

Special Valves for Turbomolecular Pumps

Solenoid Venting Valve

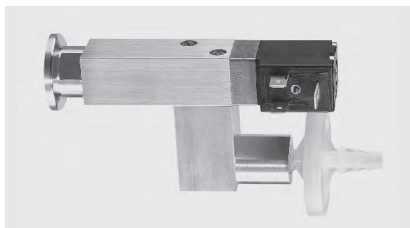

Technical Data

Technical Data		Venting Valve
Drive voltage	V DC	24
Power consumption	W	4
Connecting flange	DN	16 ISO-KF
Weight, approx.	kg (lbs)	0.3 (0.66)

Ordering Information

Ordering Information	Venting Valve
	Part No.
Solenoid venting valve, normally closed	800120V0011

Power Failure Venting Valve

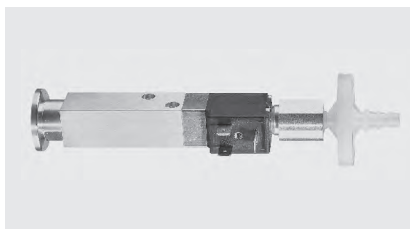

Technical Data

Technical Data		Power Failure Venting Valve
Drive voltage	V DC	24
Power consumption	W	4
Connecting flange	DN	16 ISO-KF
Weight, approx.	kg (lbs)	0.3 (0.66)

Ordering Information

Ordering Information	Power Failure Venting Valve
	Part No.
Power failure venting valve, normally open	800120V0021

Purge Gas and Venting Valve



Technical Data

Technical Data		Purge Gas and Venting Valve
Connecting flange	DN	10 ISO-KF
Weight, approx.	kg (lbs)	0.7

Ordering Information

Ordering Information	Purge Gas and Venting Valve
	Part No.
Purge gas and venting valve, 230 V	
0.2 mbar x l/s (12 sccm)	855 19
0.4 mbar x l/s (24 sccm)	855 29

Purge Gas and Venting Valve

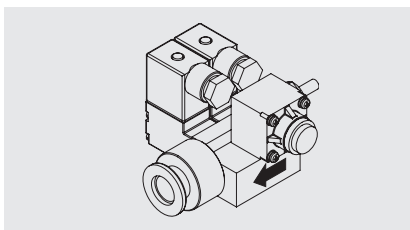

Technical Data

Technical Data		Purge Gas and Venting Valve
Connecting flange		
Inlet		1/4" tube
Outlet		pump specific or DN 16 ISO-KF
Seal gas pressure, abs.	bar	1.5 to 6.0
Weight, approx.	kg (lbs)	0.5 (1.1)

Ordering Information

Ordering Information	Purge Gas and Venting Valve
	Part No.
Purge gas and venting valve	
24 V DC; 0.6 mbar x l/s	121 33

Further 0.6 mbar x l/s valves upon request

Purge Gas and Venting Valve for ClassicLine and SL Pumps



Technical Data

Connecting flange		
Pump side	DN	10 KF
Gas connection	G	1/4"
Seal gas pressure, abs.	bar	1
Weight, approx.	kg (lbs)	0.3 (0.66)

Purge Gas and Venting Valve

Ordering Information

Purge Gas and Venting Valve

	Part No.
Purge gas and venting valve at 1 bar	
0.2 mbar x l/s (12 sccm), 110 – 115 V DC	800152V0041
0.2 mbar x l/s (12 sccm), 230 V DC	800152V0019
0.4 mbar x l/s (24 sccm), 24 V DC	800152V0013
0.4 mbar x l/s (24 sccm), 110 – 115 V DC	800152V0042
0.4 mbar x l/s (24 sccm), 230 V DC	800152V0014
0.6 mbar x l/s (36 sccm), 24 V DC	800152V0012
0.6 mbar x l/s (36 sccm), 110 – 115 V DC	800152V0043
0.6 mbar x l/s (36 sccm), 230 V DC	800152V0040

Adaptor Set for Seal Gas and Venting Valve for the SL pumps

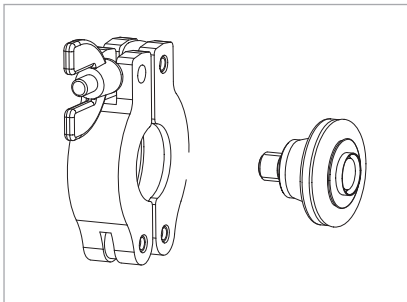

Technical Data

Pump flange adaptor M8/DN 10 ISO-KF including adaptor centering ring DN 10/DN 16 ISO-KF with sinter filter insert and clamping ring

Adaptor Set

Ordering Information

Adaptor Set

	Part No.
Adaptor set for purge gas and venting valve	800110V0011

Gas Filter to G 1/4" for Purge Gas and Venting Valve

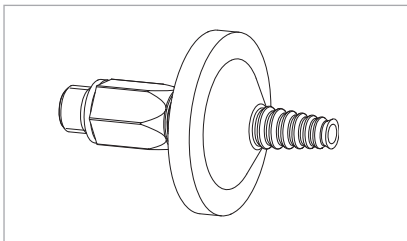

Technical Data

Gas filter including fitting G 1/4" and 2 gaskets

Gas Filter

Ordering Information

Gas Filter

	Part No.
Gas filter to G 1/4" for seal gas and venting valve	800110V0012
Replacement filter for gas filter to G 1/4" for seal gas and venting valve	E 200 18 515

UHV All-Metal Right-Angle Valves

Our UHV all metal angle valves are the reliable solution for all applications in ultra-high vacuum. The innovative design and rotatable CF flanges allow a convenient handling and an easy installation.

The reliability of the valve is achieved by the use of optimal sealing materials. The silver-coated sealing with its very long service life is maintenance-free at more than 1000 cycles. A mechanical stop prevents the valve from too much torque that might cause damages to the sealing. Also the mechanical stop indicates when the valve is fully closed. For operating the valve a plastic hand wheel and a metal T-handle are available. The advantage of the T-handle is that it suited for heating processes and does not need to be removed.

Advantages to the User

- Very reliable sealing
- Maintenance-free for over 1000 cycles
- Very easy to use, mechanical stop prevents from over torque
- T-handle available for bake out processes
- Coated spindle, no lubrication necessary
- Very high lifetime due to the coated metal sealing

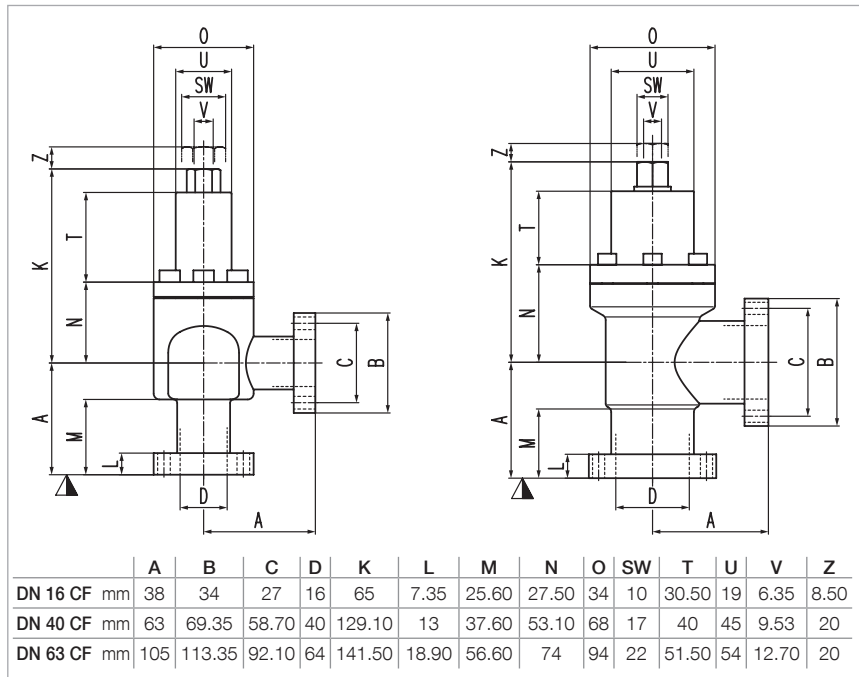

Dimensional drawing DN 16 CF (left), DN 40 / 63 CF (right)

Technical Data

UHV-All-Metal Right-Angle Valves with Rotatable Flanges on Both Sides

DN	CF	16	40	63
Connection flange rotatable	DN	16 CF-R	40 CF-R	63 CF-R
Leak rate: body, valve seat	mbar x l/s	<1 x 10 ⁻¹⁰		
Differential pressure on the plate in either direction	bar	2		
Differential pressure at opening	bar	1		
Closing force		closing to a mechanical stop		
Turns per stroke		6	11	9
Valve position indication		visual (mechanical)		
Service life	cycles	1000		
Conductance for molecular flow	l/s	5	50	105
Pressure, absolute min.	mbar	1 x 10 ⁻¹¹		
max.	bar	2		
Mounting orientation		any		
Bake out temperature	°C	≤ 300		
Max. heating and cooling rate	°C/h	≤ 60		
Bellows	Material	Stainless steel 1.4404		
Valve disk	Material	Stainless steel 1.4404, 1.4435		
Valve disk seal	Material	Metal		
Weight	kg	0.4	1.9	5.9

Ordering information

UHV-All-Metal Right-Angle Valves with Rotatable Flanges on Both Sides

	Part No.	Part No.	Part No.
UHV all-metal right-angle valves	28980V01	28981V01	28982V01
T-bar, metal	289811V01	289812V01	289813V01
Handwheel, plastic	289801V01	289802V01	-

UHV All-Metal Variable Leak Valves

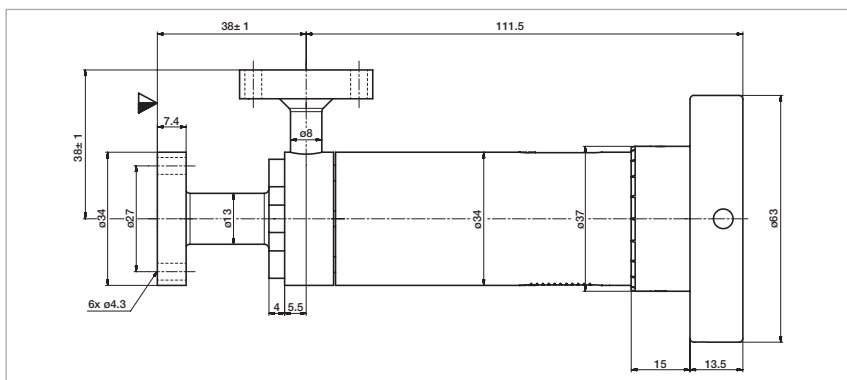

Dimensional drawing for the all-metal variable leak valves

Technical Data

UHV All-Metal Variable Leak Valves

Connection flange	DN	16 CF-R
Position indication		Linear scale - scale ring
Leak rate		
to the outside	mbar x l/s	$\leq 1 \times 10^{-10}$
seat "closed position"	mbar x l/s	$\leq 1 \times 10^{-10}$
Molecular conductance	l/s	0.05
Adjustable gas flow [air, 1 bar, RT]	mbar x l/s	1×10^{-10} - 500
Dead volume		
seat port	cm ³	2.7
side port	cm ³	1.1
Pressure range	bar (abs.)	UHV to 10
Test pressure	bar	1
Differential pressure	bar	≤ 10
Max. differential pressure at opening	bar	≤ 10
Cycles until first service		20 000
Bake-out temperature		
open	°C	≤ 300
closed	°C	≤ 300
actuator	°C	≤ 300
Heating and cooling rate	°C/h	≤ 60
Material		
body		1.4943, AISI 660 / 1.4404, AISI 316 L
diaphragm		1.4310, AISI 301, gold plated
Mounting position		any
Radiation resistance	Gy (rad)	10^8 (10^{10})
Turns from open to close		22
Weight	kg (lbs)	0.94 (2.07)

Ordering Information

UHV All-Metal Variable Leak Valves

	Part No.
UHV all-metal variable leak valve	28990V01

Gate Valves with ISO-KF / CF / ISO-F Flanges

Overview



- 1** Miniature UHV gate valves, ISO-KF flange
- 2** Miniature UHV gate valves, CF flange
- 3** UHV gate valves
- 4** HV gate valves

For the precise installation dimensions, please refer to the product's Operating Instructions.

Miniature Gate Valves, ISO-KF, Manually Operated (Articulated Lever)

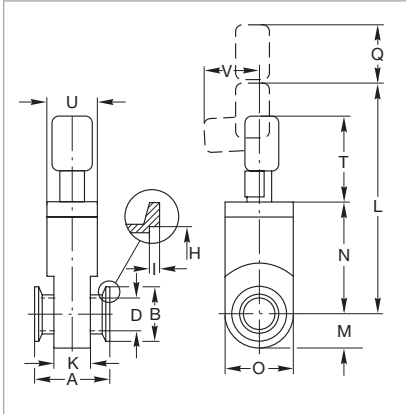

Dimensional drawing for the miniature UHV gate valves, articulated lever, ISO-KF flange

Dimension Table

DN	ISO-KF	16	25	40
A	mm	40	50	51
B	mm	30	40	55
D	mm	15	24	39
H	mm	17.2	26.2	41.2
I	mm	3	3	3
K	mm	25	32	31
L	mm	100	139	208
M	mm	15	22	32,5
N	mm	39	59	93
O	mm	30	44	65
Q	mm	25	35	55
T	mm	37	50	85
U	mm	25	32	40
V	mm	30	30	50

Advantages to the User

- Cost-effective gate valve for industrial applications with elastomer-sealed push gate feedthrough
- Aluminum body
- Slim and light-weight
- Low play in the locked state and low wear

Technical Data

Miniature Gate Valve

		DN 16 ISO-KF	DN 25 ISO-KF	DN 40 ISO-KF
Tightness				
Body	mbar x l/s	< 1 x 10 ⁻⁹		
Valve seat	mbar x l/s	< 1 x 10 ⁻⁹		
Pressure range, abs.		1 x 10 ⁻⁷ mbar to 2 bar		
High vacuum conductance	l/s	10	34	140
Differential pressure at the valve gate	bar	≤ 2 in both directions		
Max. differential pressure during opening	mbar	≤ 30		
Service life until first maintenance	cycles	50,000		
Degassing temperature for the valve	°C	100 / 100		
manual open / closed	°C	80		
Installation orientation		any		
Weight	kg	0.4	0.4	0.7
Material				
Valve body		AlMgSi1 (3.2315)		
Valve gate		AISI 301 (1.4310)		
Seal (head, gate)		Viton/Viton		

Ordering Information

Miniature Gate Valve

	DN 16 ISO-KF	DN 25 ISO-KF	DN 40 ISO-KF
	Part No.	Part No.	Part No.
Miniature gate valve, manually operated, articulated lever	286 06	286 08	286 09

Miniature UHV Gate Valves, ISO-KF and CF, Manually Operated (Handwheel)

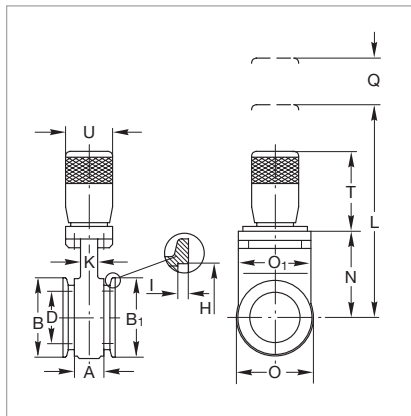

Dimensional drawing for the miniature UHV gate valves, manually operated (handwheel), DN 40 ISO-KF

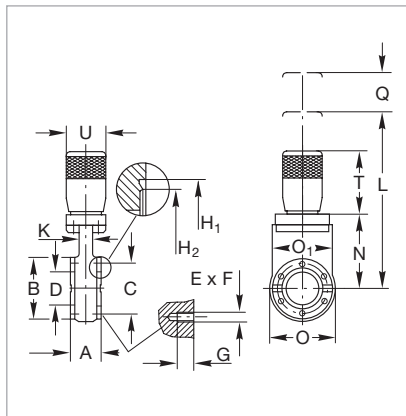

Dimensional drawing for the miniature UHV gate valves, manually operated (handwheel), DN 40 CF

Advantages to the User

- Bellows-sealed feedthrough
- Valve technology with only one moving part
- Equipped with a mechanical position indicator
- Low particle generating and vibration free actuation
- Compact design

Dimension Table

DN		40 ISO-KF	40 CF
A	mm	50	35
B	mm	72	72
B ₁	mm	55	-
C	mm	-	58,7
D	mm	40	40
E x F		-	6 x M 6
G	mm	-	7
H	mm	41.2	-
H ₁	mm	-	48.3
H ₂	mm	-	42
I	mm	3	-
K	mm	16	16
L	mm	198	198
N	mm	82	82
O	mm	76	76
O ₁	mm	70	70
Q	mm	55	55
T	mm	73	73
U	mm	45	45

Technical Data

Miniature UHV Gate Valve

DN 40 ISO-KF

DN 40 CF

Tightness			
Body	mbar x l/s		$< 5 \times 10^{-10}$
Valve seat	mbar x l/s		$< 1 \times 10^{-9}$
Pressure range, abs.			1×10^{-10} mbar to 2 bar
High vacuum conductance	l/s	160	220
Differential pressure at the valve gate	bar		≤ 2 in both directions
Max. differential pressure during opening	mbar		≤ 30
Service life until first maintenance	cycles		50,000
Degassing temperature			
valve open / closed	°C		250 / 200
manually operated	°C		250
Installation orientation			any
Weight	kg		1.5
Material			
Valve body			AISI 304 (1.4301)
Valve gate			AISI 304 (1.4301)
Bellows			AISI 316 L (1.4435)
Seal (head, gate)			Viton/Viton

Ordering Information

Miniature UHV Gate Valve

DN 40 ISO-KF

DN 40 CF

	Part No.	Part No.
Miniature gate valve, manually operated, handwheel	286 15	286 84
6 set screws with nuts and washers ¹⁾	-	839 11

¹⁾ For dimensions E x F see table "Connections for CF"

Miniature UHV Gate Valves, ISO-KF / CF, Electropneumatically Operated

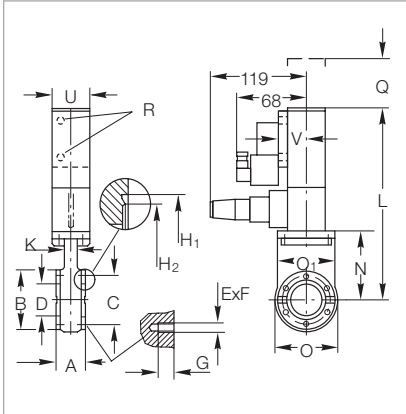

Dimensional drawing for the miniature UHV gate valves; electropneumatically operated, CF flange

Advantages to the User

- Double-acting electropneumatic actuator (with position indicator and pilot valve); bellows-sealed feedthrough
- Valve technology with only one moving part
- Equipped with a mechanical position indicator
- Actuation free of particles and vibrations
- Short closing time, very long service life
- Compact design

Dimension Table

DN		40 ISO-KF	40 CF
A	mm	51	35
B	mm	55	72
C	mm	-	58.7
D	mm	40	40
E x F		-	6 x M 6
G	mm	-	7
H	mm	41.2	-
H ₁	mm	-	48.3
H ₂	mm	-	42
I	mm	3	-
K	mm	31	16
L	mm	196	230
M	mm	32.5	-
N	mm	88	82
O	mm	65	76
O ₁	mm	-	70
Q	mm	55	55
T	mm	-	73
U	mm	40	45
V	mm	65	32.5
W	mm	61	-
W ₁	mm	50	-

Technical Data

Miniature UHV Gate Valve

DN 40 ISO-KF (Stainless Steel)

DN 40 CF (Stainless Steel)

Tightness			
Body	mbar x l/s		$< 5 \times 10^{-10}$
Valve seat	mbar x l/s		$< 1 \times 10^{-9}$
Pressure range, abs.			1×10^{-10} mbar to 2 bar
High vacuum conductance	l/s	160	220
Differential pressure at the valve gate	bar		≤ 2 in both directions
Max. differential pressure during opening	mbar		≤ 30
at reduced service live	bar		1
Service life until first maintenance	cycles		50,000
Degassing temperature			
Valve open / closed	°C		$\leq 250 / 200$
pneumatic actuation	°C		≤ 200
position indicator / pilot valve	°C		80 / 50
Warming-up and cooling down speed	°C x h ⁻¹		50
Compressed air, min. / max.	bar		4.5 / 7.0
Closing time / opening time	s		0.7
Pilot valve			
supply voltage / power consumption			24 V DC / 6 W or 230 V AC, 50/60 Hz / 2 W
Switching capacity of the position indicator at 80 °C	A		5 at 250 V AC; 3 at 50 V DC
Installation orientation			any
Weight	kg		1.8
Material			
Valve body			AISI 304 (1.4301)
Valve gate			AISI 304 (1.4301)
Bellows			AISI 316 L (1.4435)
Seal (head, gate)			Metal/Viton

Ordering Information

Miniature UHV Gate Valve

DN 40 ISO-KF (Stainless Steel)

DN 40 CF (Stainless Steel)

	Part No.	Part No.
Miniature gate valve, electropneumatically operated		
24 V DC / 6 W	286 36	286 99
230 V AC, 50/60 Hz / 2 W	286 35	286 94
6 set screws with nuts and washers ¹⁾	-	839 11

¹⁾ For dimensions E x F see table "Connections for CF"

HV Gate Valves, ISO-F Manually Operated

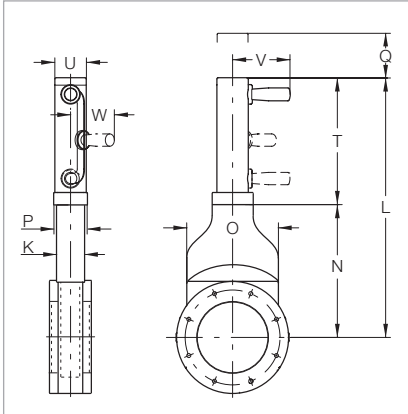

Dimensional drawing for the HV gate valves; manually operated, DN 63 ISO-F and DN 100 ISO-F

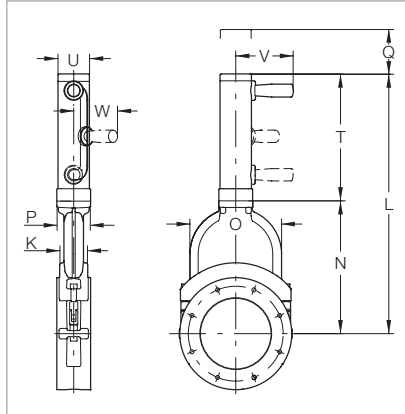

Dimensional drawing for the HV gate valves; manually operated, DN 160 ISO-F

Advantages to the User

- Cost-effective gate valve for industrial applications with elastomer-sealed push gate feedthrough
- Aluminum body
- Slim and light-weight
- Low play in the locked state and low wear

Dimension Table

DN	ISO-F	63	100	160
K	mm	36	36	58
L	mm	329.5	41	547
N	mm	155.5	203.5	280
O	mm	100	140	192
P	mm	48	48	70
Q	mm	25	25	60
T	mm	174	209.5	267
U	mm	43	43	65
V	mm	94	94	122
W	mm	75	75	95

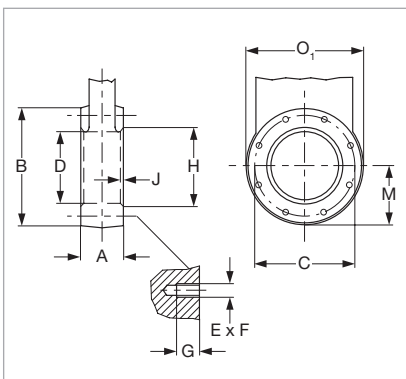

Connection dimensions for ISO-F flanges (HV gate valves)

Connections for ISO-F

DN	ISO-F	63	100	160
A	mm	60	60	70
B	mm	130	165	235
C	mm	110	145	200
D	mm	65	100	150
E x F		4 x M8	8 x M8	8 x M10
G	mm	12	12	16
H	mm	70	102	153
J	mm	3	3	5
M	mm	65.5	83	117.5
O ₁	mm	131	166	237

Technical Data

		HV Gate Valve		
		DN 63 ISO-F	DN 100 ISO-F	DN 160 ISO-F
Tightness				
Body	mbar x l/s	< 1 x 10 ⁻⁹		
Valve seat	mbar x l/s	< 1 x 10 ⁻⁹		
Pressure range, abs.		1 x 10 ⁻⁷ mbar to 1.6 bar		
High vacuum conductance	l/s	550	2000	6000
Differential pressure at the valve gate	bar	1.6 in both directions		
Max. differential pressure during opening	mbar	≤ 30		
Service life until first maintenance	cycles	200,000	200,000	100,000
Degassing temperature				
valve	°C	120		
manually operated	°C	80		
Installation orientation		any		
Weight	kg	3	4.5	9
Material				
Valve body		AlMg4.5Mn		
Valve gate		AISI 304 (1.4301)		
Mechanism		AISI 301 (1.4310), AISI 304(1.4301), AISI 420 (1.4034)		
Seal (head, gate)		Viton		

Ordering Information

		HV Gate Valve		
		DN 63 ISO-F	DN 100 ISO-F	DN 160 ISO-F
		Part No.	Part No.	Part No.
HV gate valve, manually operated		286 25	286 26	215 633
Set screws with nuts and washers ¹⁾		839 13	839 13	210 071
(Package each containing)	pieces	16	16	12

¹⁾ For dimensions E x F see table "Connections for ISO-F"

HV Gate Valves, ISO-F, Electropneumatically Operated

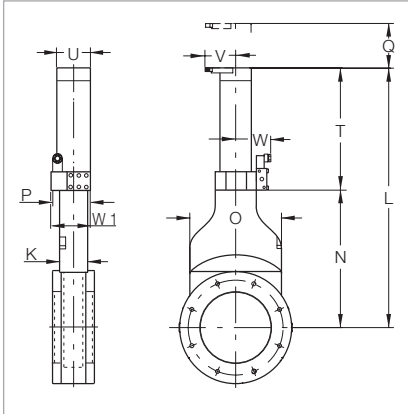

Dimensional drawing for the gate valves;
DN 63 ISO-F and DN 100 ISO-F

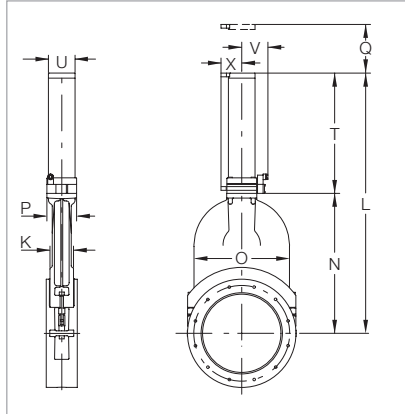

Dimensional drawing for the gate valves;
DN 160 ISO-F to DN 250 ISO-F

Advantages to the User

- Cost-effective gate valve for industrial applications with elastomer-sealed push gate feedthrough
- Aluminum body
- Slim and light-weight
- Low play in the locked state and low wear
- Double-acting
- With position indicator

Dimension Table

DN	ISO-F	63	100	160	200	250
K	mm	36	36	58	66	76
L	mm	341.5	424	547	688	843
N	mm	155.5	203.5	280	363.5	453
O	mm	100	140	192	240	308
P	mm	58	58	70	80	96
Q	mm	25	25	60	80	100
T	mm	186	221.5	267	324.5	390
U	mm	55	55	65	75	86
V	mm	56	56	71.5	76.5	84.5
W	mm	72	72	-	-	-
W ₁	mm	65.5	65.5	-	-	-
X	mm	59	59	57	62	67

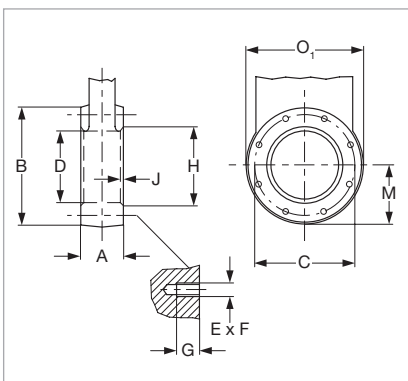

Connection dimensions for ISO-F flanges
(HV Gate Valves)

Connections for ISO-F

DN	ISO-F	63	100	160	200	250
A	mm	60	60	70	80	100
B	mm	130	165	235	288	350
C	mm	110	145	200	260	310
D	mm	65	100	150	200	261
E x F		4 x M8	8 x M8	8 x M10	12 x M10	12 x M10
G	mm	12	12	16	16	16
H	mm	70	102	153	213	-
J	mm	3	3	5	5	-
M	mm	65.5	83	117.5	144	175
O ₁	mm	131	166	237	290	352

Technical Data

HV Gate Valve

DN 63 ISO-F DN 100 ISO-F DN 160 ISO-F DN 200 ISO-F DN 250 ISO-F

Tightness						
Body	mbar x l/s	$< 1 \times 10^{-9}$				
Valve seat	mbar x l/s	$< 1 \times 10^{-9}$				
Pressure range, abs.		1 x 10 ⁻⁷ mbar to 1.6 bar	1 x 10 ⁻⁷ mbar to 1.6 bar	1 x 10 ⁻⁷ mbar to 1.6 bar	1 x 10 ⁻⁷ mbar to 1.6 bar	1 x 10 ⁻⁷ mbar to 1.2 bar
High vacuum conductance	l/s	550	2000	6000	12000	22000
Max. Differential pressure at the valve gate	mbar	≤ 1600 in both directions	≤ 1600 in both directions	≤ 1600 in both directions	≤ 1600 in both directions	≤ 1200 in both directions
Max. differential pressure during opening	mbar	≤ 30				
Compressed air, min. / max.	bar	4 / 7				
Closing time / opening time	s	1.5	2	2	3	5
Service life until first maintenance	cycles	200,000	200,000	100,000	100,000	100,000
Degassing temperature						
valve	°C	120				
pneumatic drive	°C	80				
position indicator	°C	80				
pilot valve	°C	50				
Switching capacity for the position indicator	A	5 at 230 V AC; 3 at 50 V DC				
Installation orientation		any				
Weight	kg	3	4.5	9	18	25
Material						
Valve body		AlMg4.5Mn	AlMg4.5Mn	G-AISI7Mg	G-AISI7Mg	G-AISI7Mg
Valve gate		AISI 304 (1.4301)	AISI 304 (1.4301)	AlMgSi1,	AlMgSi1,	AlMgSi1,
Mechanism		AISI 301 (1.4310), AISI 304 (1.4301), AISI 420 (1.4034)	AISI 301 (1.4310), AISI 304 (1.4301), AISI 420 (1.4034)	AISI 301 (1.4310), AISI 304 (1.4301), AISI 420 (1.4034)	AISI 301 (1.4310), AISI 304 (1.4301), AISI 420 (1.4034)	AISI 301 (1.4310), AISI 304 (1.4301), AISI 420 (1.4034)
Seal (head, gate)		Viton/Viton	Viton/Viton	Viton/Viton	Viton/Viton	Viton/Viton

Ordering Information

HV Gate Valve

DN 63 ISO-F DN 100 ISO-F DN 160 ISO-F DN 200 ISO-F DN 250 ISO-F

	Part No.	Part No.	Part No.	Part No.	Part No.
HV gate valve, electropneumatically operated					
24 V DC / 2.5 W	286 55	286 56	-	-	-
24 V DC / 6 W	-	-	215 643	215 644	215 645
230 V AC, 50 Hz / 7.1 W	286 45	286 46	215 653	215 654	215 655
Set screws with nuts and washers ¹⁾					
(Package each containing)	pieces	pieces	pieces	pieces	pieces
	16	16	12	12	12

¹⁾ For dimensions E x F see table "Connections for ISO-F"

UHV Gate Valves, CF Manually Operated

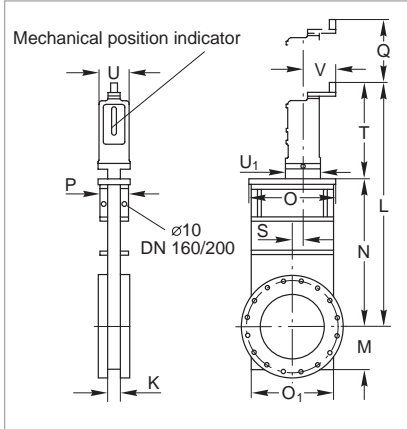

Dimensional drawing for the UHV gate valves
DN 63 CF to DN 160 CF

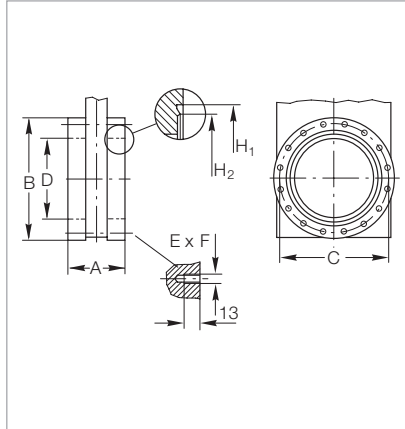

Connection dimensions for CF flanges

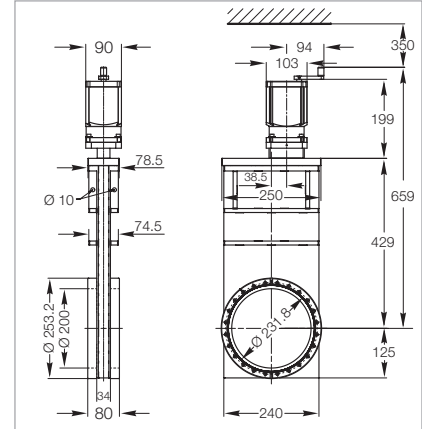

Dimensional drawing for the UHV gate valve
DN 200 CF

Dimension Table

DN	CF	63	100	160
K	mm	27	27	27
L	mm	408	462	552
M	mm	57	73	99
N	mm	192	247	336
O	mm	115	145	200
O ₁	mm	112	142	192
P	mm	70	70	70
Q	mm	180	220	290
S	mm	11	9	25
T	mm	184	184	184
U	mm	70	70	70
U ₁	mm	83	83	83
V	mm	77	77	77

Connections for CF

DN	CF	63	100	160
A	mm	70	70	70
B ₂	mm	113.5	151.6	202.4
C	mm	92.1	130.2	181
D	mm	70	100	150
E x F	mm	8 x M8	16 x M8	20 x M8
H ₁	mm	82.5	120.65	171.45
H ₂	mm	77.4	115.5	166

Advantages to the User

- Valve and wheel can be degassed at temperatures up to 250 °C (up to 200 °C when closed)
- Stainless steel body (non-rusting)
- Bellows-sealed feedthrough
- Low play in the locked state and low wear
- Compact
- Mechanically locked in the closed state
- Mechanical position indicator

Technical Data

		UHV Gate Valve			
		DN 63 CF	DN 100 CF	DN 160 CF	DN 200 CF
Tightness	Body	$< 5 \times 10^{-9}$			
	Valve seat	$< 1 \times 10^{-9}$			
Pressure range, abs.		1×10^{-10} mbar to 1.6 bar			
High vacuum conductance	l/s	600	1700	6000	12000
Differential pressure at the valve gate	bar	≤ 1.6 in both directions			
Max. differential pressure during opening	mbar	≤ 30			
Number of spindle turns for full travel		10	13	17	17
Service life until first maintenance	cycles	50,000			
Degassing temperature	valve open / closed	$250 / 200$			
	manually operated	250			
Warming-up / cooling down speed	$^{\circ}\text{C} \times \text{h}^{-1}$	50			
Installation orientation		any			
Weight	kg	9	12	18	28
Material		AISI 304 (1.4301)			
Body		AISI 316 L (1.4435)			
Bellows		AISI 304 (1.4301), AISI 316 L (1.4404), AISI 301 (1.4310), AISI 420 (1.4034)			
Mechanism		Metal/Viton			
Seal (head, gate)		Metal/Viton			

Ordering Information

		UHV Gate Valve			
		DN 63 CF	DN 100 CF	DN 160 CF	DN 200 CF
		Part No.	Part No.	Part No.	Part No.
UHV gate valve, manually operated		286 85	286 86	286 87	286 88
16 set screws with nuts and washers ¹⁾		839 13	839 13	2 x 839 13	2 x 839 13

¹⁾ For dimensions E x F see table "Connections for ISO-F"

UHV Gate Valves, ISO-F, Electropneumatically Operated

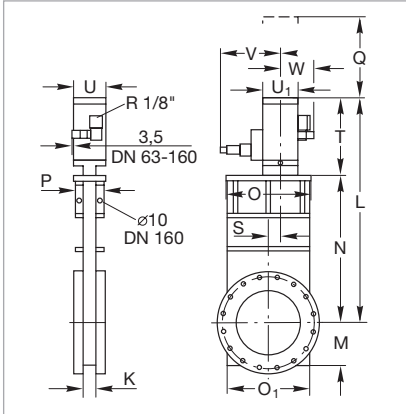

Dimensional drawing for the UHV gate valves ISO-F

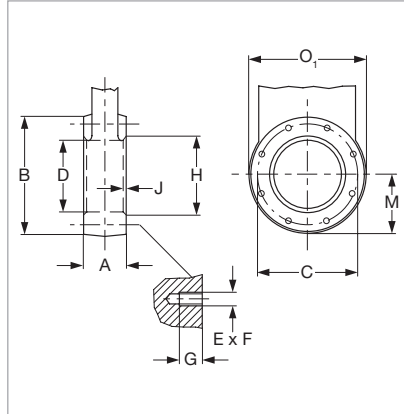

Connection dimensions for ISO-F flanges (UHV gate valves)

Advantages to the User

- Valve and pneumatic drive can be degassed at temperatures up to 250 °C and 200 °C respectively
- Stainless steel body (non-rusting)
- Double-acting electropneumatic actuator (with position indicator and pilot valve)
- Bellows-sealed feedthrough
- Low play in the locked state and low wear
- Compact
- Mechanically locked in the closed state

Dimension Table

DN	ISO-F	100	160	250
K	mm	27	27	41
L	mm	418	523	800
M	mm	73	99	161
N	mm	247	336	560
O	mm	145	200	345
O ₁	mm	142	192	322
P	mm	70	70	80
Q	mm	220	290	450
S	mm	9	25	65
T	mm	171	187	240
U	mm	70	70	90
U ₁	mm	83	83	103
V	mm	145	145	155
W	mm	77	77	87

Connections for ISO-F

DN	ISO-F	100	160	250
A	mm	70	70	100
B	mm	165	225	350
C	mm	145	200	310
D	mm	100	150	261
E x F		8 x M8	8 x M10	12 x M10
G	mm	13	13	15
H	mm	102	153	-
J	mm	3	5	-

Technical Data

UHV Gate Valve

		DN 100 ISO-F	DN 160 ISO-F	DN 250 ISO-F
Tightness				
Body	mbar x l/s	< 5 x 10 ⁻¹⁰		
Valve seat	mbar x l/s	< 1 x 10 ⁻⁹		
Pressure range, abs.		1 x 10 ⁻¹⁰ mbar to 1 bar		
High vacuum conductance	l/s	1700	6000	26000
Differential pressure at the valve gate	bar	1 in both directions		
Max. differential pressure during opening	mbar	30		
Compressed air, min. / max.	bar	4 / 7	4 / 7	5 / 7
Closing time / opening time	s	1.2	1.5	4
Compressed air cylinder, volume	l	0.11	0.14	0.35
Service life until first maintenance	cycles	50,000		
Degassing temperature				
valve open / closed	°C	250 / 200		
pneumatic drive	°C	200		
position indicator	°C	80		
pilot valve	°C	50		
Warming-up / cooling down speed	°C x h ⁻¹	50		
Pilot valve supply voltage / power consumption		24 V DC / 6 W or 230 V AC, 50 Hz / 7.1 W	24 V DC / 6 W or 230 V AC, 50 Hz / 7.1 W	24 V DC / 6 W
Switching capacity of the position indicator at 80 °C	A	5 at 250 V AC; 3 at 50 V DC		
Installation orientation		any		
Weight	kg	12	18	42
Material				
Body		AISI 304 (1.4301)		
Bellows		AISI 316 L (1.4435)		
Mechanism		AISI 304 (1.4301), AISI 316 L (1.4404), AISI 301 (1.4310), AISI 420 (1.4034)		
Seal (head, gate)		Metal/Viton		

Ordering Information

UHV Gate Valve

		DN 100 ISO-F	DN 160 ISO-F	DN 250 ISO-F
		Part No.	Part No.	Part No.
UHV gate valve, electropneumatically operated				
24 V DC / 6 W		286 73	286 74	286 81
230 V AC, 50 Hz / 7.1 W		286 76	286 77	-
Set screws with nuts and washers ¹⁾				
(Package each containing)	pieces	839 13 16	210 071 12	210 071 12

¹⁾ For dimensions E x F see table "Connections for ISO-F"

UHV Gate Valves, CF, Electropneumatically Operated

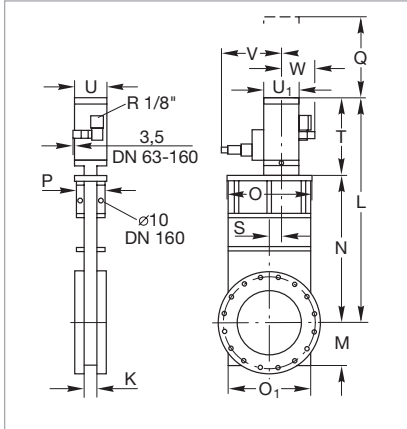

Dimensional drawing for the UHV gate valves DN 63 CF to DN 160 CF electropneumatically operated

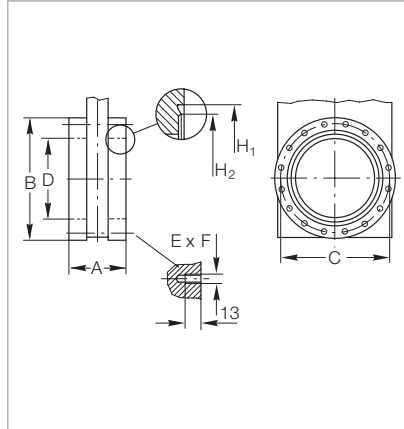

Connection dimension for CF flanges DN 63 CF to DN 160 CF

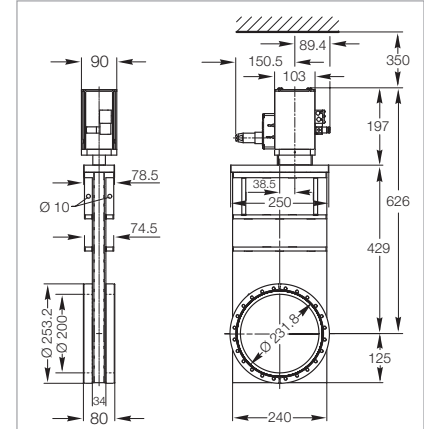

Dimensional drawing for the UHV gate valve DN 200 CF electropneumatically operated

Dimension Table

DN	CF	63	100	160	200
K	mm	27	27	27	35
L	mm	346	418	523	630
M	mm	57	73	99	125
N	mm	192	247	336	430
O	mm	115	145	200	250
O ₁	mm	112	142	192	240
P	mm	70	70	70	80
Q	mm	180	220	290	350
S	mm	11	9	25	38,5
T	mm	154	171	187	200
U	mm	70	70	70	90
U ₁	mm	83	83	83	103
V	mm	145	145	145	155
W	mm	77	77	77	87

Connections for CF

DN	CF	63	100	160	200
A	mm	70	70	70	80
B ₂	mm	113.5	151.6	202.4	253.2
C	mm	92.1	130.2	181	231.8
D	mm	70	100	150	200
E x F		8 x M8	16 x M8	20 x M8	24 x M8
H ₁	mm	82.5	120.65	171.45	222.3
H ₂	mm	77.4	115.5	166	217

Advantages to the User

- Double-acting electropneumatic actuator (with position indicator and pilot valve)
- Bellows-sealed feedthrough
- Valve and pneumatic drive can be degassed at temperatures up to 250 °C and 200 °C respectively
- Stainless steel body (non-rusting)
- Low play in the locked state and low wear
- Compact
- Mechanically locked in the closed state

Technical Data

UHV Gate Valve

		DN 63 CF	DN 100 CF	DN 160 CF	DN 200 CF
Tightness					
Body	mbar x l/s	< 5 x 10 ⁻¹⁰			
Valve seat	mbar x l/s	< 1 x 10 ⁻⁹			
Pressure range, abs.		1 x 10 ⁻¹⁰ mbar to 1 bar			
High vacuum conductance	l/s	600	1700	6000	12000
Differential pressure at the valve gate	bar	1 in both directions			
Max. differential pressure during opening	mbar	30			
Compressed air, min. / max.	bar	4 / 7	4 / 7	4 / 7	5 / 7
Closing time / opening time	s	1	1.2	1.5	4
Compressed air cylinder, volume	l	0.08	0.11	0.14	0.35
Service life until first maintenance	cycles	50,000			
Degassing temperature					
Valve open / closed	°C	250 / 200			
Pneumatic drive	°C	200			
Position indicator	°C	80			
Pilot valve	°C	50			
Warming-up / cooling down speed	°C x h ⁻¹	50			
Pilot valve supply voltage / power consumption		24 V DC / 6 W or 230 V AC, 50 Hz / 7.1 W			
Switching capacity of the position indicator at 80 °C	A	5 at 250 V AC; 3 at 50 V DC			
Installation orientation		any			
Weight	kg	9	12	18	28
Material					
Body		AISI 304 (1.4301)			
Bellows		AISI 316 L (1.4435)			
Mechanism		AISI 304 (1.4301), AISI 316 L (1.4404), AISI 301 (1.4310), AISI 420 (1.4034)			
Seal (head, gate)		Metal/Viton			

Ordering Information

UHV Gate Valve

	DN 63 CF	DN 100 CF	DN 160 CF	DN 200 CF
	Part No.	Part No.	Part No.	Part No.
UHV gate valve, electropneumatically operated				
24 V DC / 6 W	286 89	286 90	286 91	286 92
230 V AC, 50 Hz / 7.1 W	286 95	286 96	286 97	-
16 set screws with nuts and washers ¹⁾	839 13	839 13	2 x 839 13	2 x 839 13

¹⁾ For dimensions E x F see table "Connections for CF"

