

SW25 System

Tools enabling Innovation

Membrane Solutions for the Pilot Plant

Pilot Membrane System

The MMS SW25 System is an easy to use pilot membrane device for microfiltration, ultrafiltration, nanofiltration and reverse osmosis operations.

Applications such as fractionation, purification and concentration of molecules can be tested.

The pilot system SW25 can be equipped with different types of modules for test applications up to 40 bar.

Key Features

- Speed control of pressure & circulation pumps for variable membrane crossflow velocity
- High operating pressures
- Testing of spiral wound, ceramic, hollow fibre and tubular elements (wide range of membranes available)
- Multitube heat exchanger for temperature regulation
- HMI interface with data logging

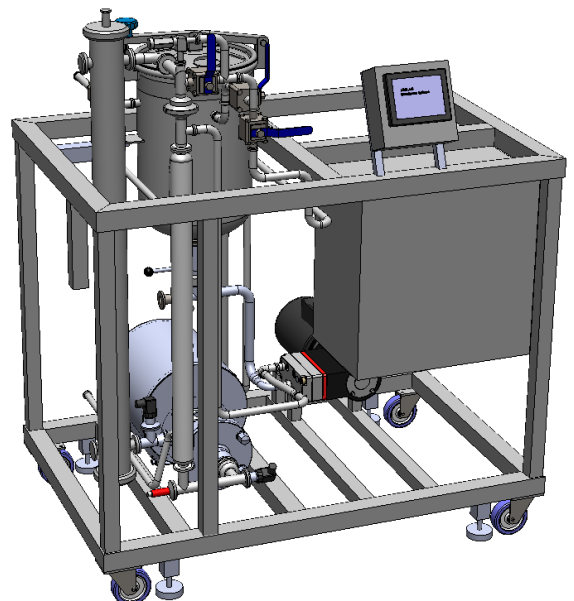

SW25 System

Tools enabling Innovation

Applications

Food & Extract Sector

- Protein fractionation & concentration
- Extract fractionation & concentration
- Hydrolysate fractionation & concentration
- Sugar fractionation & concentration
- De-alcoholization of beer and wine
- Soya milk de-bittering

Bio-Pharmaceutical Sector

- Fermentation broth clarification
- Enzyme & protein concentration
- Peptide concentration & de-salting
- API purification & concentration
- Oligosaccharide purification & concentration
- Solvent recovery or exchange

Natural Oils Sector

- De-waxing
- De-colourization
- Purification
- Concentration
- Oil/water separation

Aroma and Colorant Sector

- Herbal extract fractionation & concentration
- Natural colour purification & concentration
- Aroma sterilization
- Aroma concentration
- Evaporator condensate treatment

Chemical Sector

- Acid/caustic recovery
- Catalyst separation
- Solvent exchange & recovery
- Polymer purification & concentration
- Condensate water purification

Biofuels Sector

- Organic acid clarification & purification
- Organic acid concentration
- Sugar clarification & concentration
- Ethanol purification
- Condensate water recovery

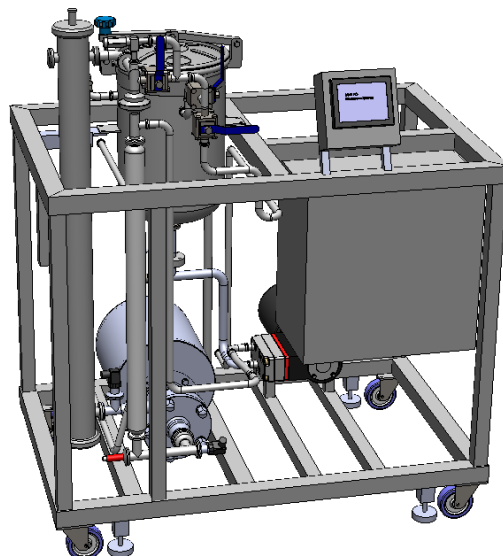

SW25 System

Tools enabling Innovation

Specifications

Dimensions (L x W x H)	1400 x 1000 x 1800 (mm), frame mounted on wheels
Weight	200 kg
Installed power requirement	3 kW (400V/50Hz)
Membrane type	Spiral wound 2538 / 2540 module (other membrane types available)
Membrane area	1.7 – 2.2 m ² (spiral wound)
Pressure pump	High pressure pump (speed controlled), with CIP and SIP capability
Circulation pump	Centrifugal pump (speed controlled)
Permeate flow rate	Permeate flow 10 – 30 l/h (flow rate is dependent on the feed characteristics)
Flow rate	Feed flow 450 l/h, circulation flow 3 500 l/h
Tubing	All tubing and fittings Mat. 316 L
Feed tank	Stainless steel 316L, Volume 25 l
Dead volume	3 – 4 l (dependent on module used)
Instruments	2 x Pressure transducers (0 – 50 bar) 1 x Temperature transducer (0 – 100 °C) 1 x Flow meter (magnetic), on permeate side
Gaskets, Seals & O-rings	EPDM (others on request)
Pressure rating	PN40 (PN60 on request)
Temperature rating	5 – 80 °C (polystat required)
HMI	Touch panel for process control, indication of parameters and data logging

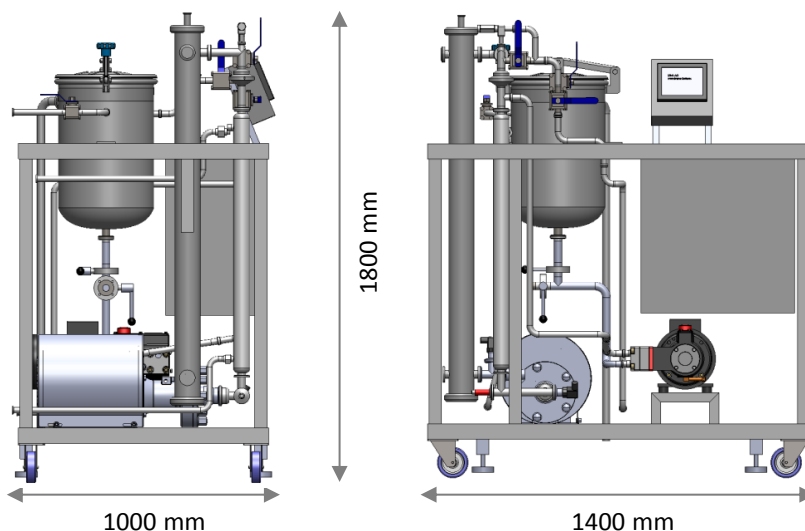

SW25 System

Tools enabling Innovation

Options

Diafiltration Kit

A peristaltic pump, integrated into the control unit, can be used for continuous diafiltration process.

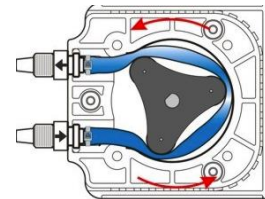

Solvent Module Kit

A housing suitable for the solvent stable module is available. The seals, O-rings and membranes for pump will be delivered in solvent stable polymer.



Purged Tank Kit

The process tank is modified to allow for nitrogen purging operations.



Different Modules

SW	Spiral wound modules 2540/2538
HF	Hollow fibre modules 3"
Ceram	Ceramic 25 mm elements
Tub	Tubular modules (on request)



Membrane Cut-Offs

SW Microfiltration	0.3 µm
SW Ultrafiltration	2.5, 3.5, 5, 10, 50 kDa
SW Nanofiltration	150 Da, 300 Da, 1000 Da
SW Reverse Osmosis	93% & 99% NaCl rejection
HF Microfiltration	0.2 & 0.5 µm
HF Ultrafiltration	10, 30, 50 & 150 kDa
Ceramic - Microfiltration	0.1, 0.2, 0.45, 0.8, 1.4 µm
Ceramic - Ultrafiltration	15, 50, 150, 300 kDa
Ceramic - Nanofiltration	500 Da, 700 Da, 1000 Da

